TRI LOK
TRIPLE OFFSET VALVES
TECHNICAL SALES MANUAL



CERTIFICATIONS



American Bureau of Shipping



National Association of Corrosion Engineers



EXIDA - Safety Integrity Level (SIL)



Lloyd's Register - LRQA - ISO 9001



Conformité Européenne - European Conformity



American Petroleum Institute



Bureau Veritas - Testing, Inspection and Certification



TÜV Rheinland - Materials Testing and Inspection

TABLE OF CONTENTS		Page	
Valve Part Numbering System		4	
Recommended Valve Installation		5	
Actuator & Gear Orientations		6	
Overall Dimensions & Weights	Class 150	8	
	Class 300	10	
	Class 600	12	
Disc Protrusion	Diagram	13	
	Class 150	14	
	Class 300	15	
	Class 600	16	
Flow Capacity (C_v / K_v)		17	
Pressure Temperature Ratings	Charts	18	
	ASTM A216 WCB	19	
	ASTM A351 CF8M	20	
	ASTM A352 LCB	21	
Flange Bolting	Sample Diagram	22	
	Class 150	Wafer	23
		Lug	24
		Double Flange	25
		Gate	26
	Class 300	Wafer	27
		Lug	28
		Double Flange	29
		Gate	30
	Class 600	Double Flange	30

VALVE PART NUMBERING SYSTEM

SERIES

XX

SIZE

XXXX

TRI LOK BASE NUMBER

110XX

TRIM CODE:

XXX

1. Body Style

L	Lug
F	Double Flanged
G	Gate Body
W	Wafer Body

2. ASME Class

0	150
1	300
2	600

4. Body Drilling

11075*	ASME B16.5 or B16.47 Series A Class 150 & 300
1101B*	ASME B16.47 Series B Class 150 & 300
110EZ*	ASME B16.5 Class 600
110G0	Factory mounted gear

3. Size in inches

0300	3"
0400	4"
0600	6"
0800	8"
1000	10"
1200	12"
1400	14"
1600	16"
1800	18"
2000	20"
2400	24"
2800	28"
3000	30"
3200	32"
3600	36"
4000	40"
4200	42"
4800	48"

Example:
L1-1800-11075-09K
 18 inch, Lug body, ASME Class 300 Tri Lok Valve with 09K trim.

† Maximum application temperature dependent on size.

3" & 4"	WCB - 800°F (425°C), LCB 650°F (343°C)
6" - 12"	482°F (250°C)
14" & 16"	392°F (200°C)
18" - 24"	302°F (150°C)

*Bare stem valves to be actuated at a Bray authorized facility.
 **Not suitable above 600°F (315°C)

5. Trim Code

4R5	Body	ASTM A216 WCB
	Body Seat	Nitrided Stainless Steel
	Disc	ASTM A216 WCB
	Seal Ring	ASTM A240 UNS S31803 + Graphite
4D6	Stem	ASTM A564-Type 630 H1150D**
	Body	ASTM A216 WCB
	Body Seat	Nitrided Stainless Steel
	Disc	ASTM A216 WCB
4K4[†]	Seal Ring	ASTM A240 UNS S31803 + Graphite
	Stem	ASTM A564-Type 630 H1150D**
	Body	ASTM A216 WCB
	Body Seat	Nitrided Stainless Steel
4C9[†]	Disc	ASTM A351 CF8M
	Seal Ring	ASTM A240 UNS S31803 + Graphite
	Stem	ASTM A479-XM 19
	Body	ASTM A351 CF8M
09K	Body Seat	Nitrided Stainless Steel
	Disc	ASTM A351 CF8M
	Seal Ring	ASTM A240 UNS S31803 + Graphite
	Stem	ASTM A564-Type 630 H1150D**
09L	Body	ASTM A351 CF8M
	Body Seat	Nitrided Stainless Steel
	Disc	ASTM A351 CF8M
	Seal Ring	ASTM A240 UNS S31803 + Graphite
4T6	Stem	ASTM A479-XM 19
	Body	ASTM A352 LCB
	Body Seat	Nitrided Stainless Steel
	Disc	ASTM A352 LCB
4T6	Seal Ring	ASTM A240 UNS S31803 + Graphite
	Stem	ASTM A564-Type 630 H1150D**
	Body	ASTM A352 LCB
	Body Seat	Nitrided Stainless Steel
4T7[†]	Disc	ASTM A351 CF8M
	Seal Ring	ASTM A240 UNS S31803 + Graphite
	Stem	ASTM A564-Type 630 H1150D**
	Body	ASTM A352 LCB
4T8[†]	Body Seat	Nitrided Stainless Steel
	Disc	ASTM A351 CF8M
	Seal Ring	ASTM A240 UNS S31803 + Graphite
	Stem	ASTM A479-XM 19

RECOMMENDED VALVE INSTALLATION

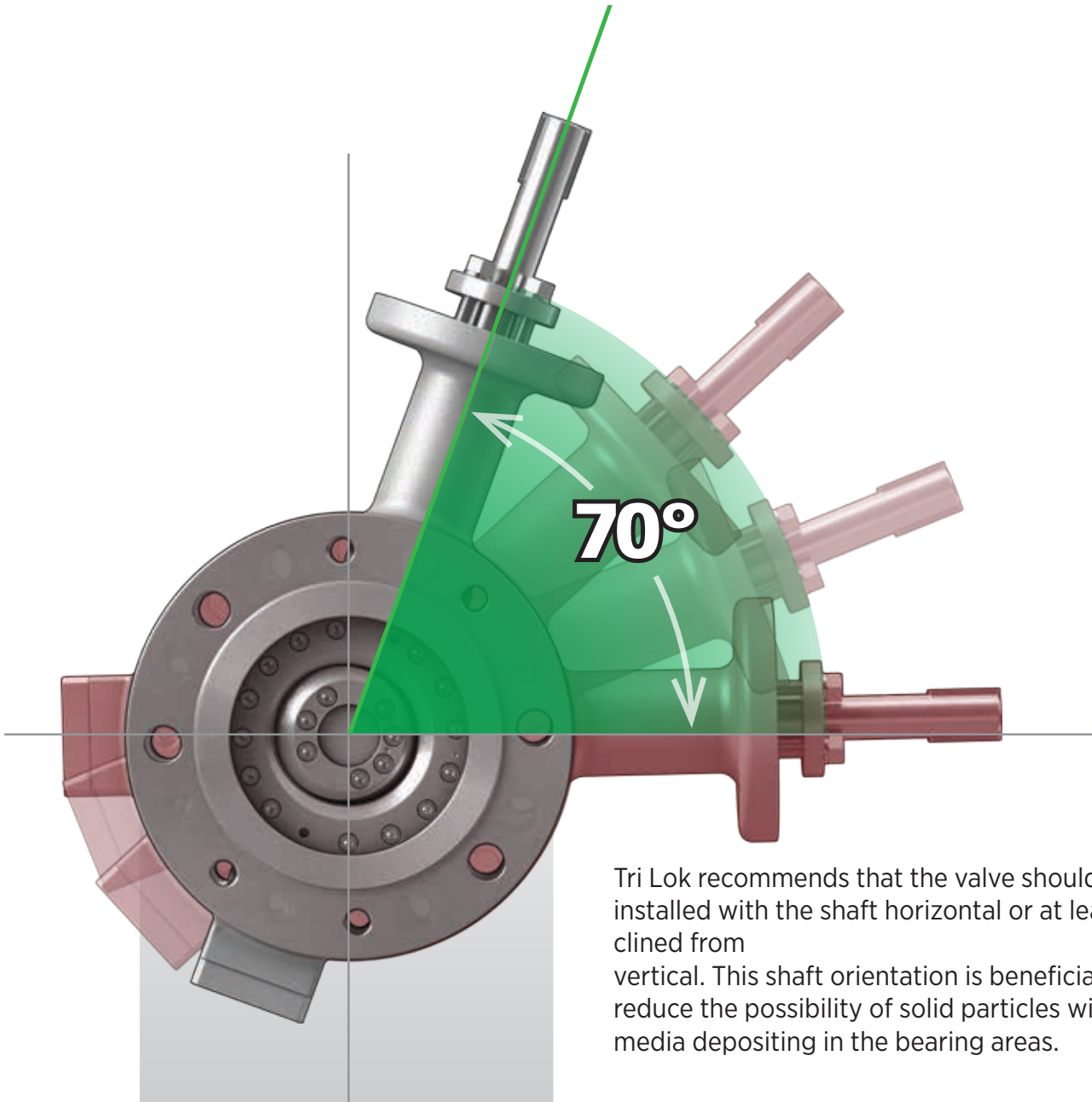

Tri Lok recommends that the valve should be installed with the shaft horizontal or at least declined from vertical. This shaft orientation is beneficial to reduce the possibility of solid particles within the media depositing in the bearing areas.



← Preferred Flow
stem on the upstream (Pressure Side)

ACTUATOR ORIENTATIONS

2H
Standard

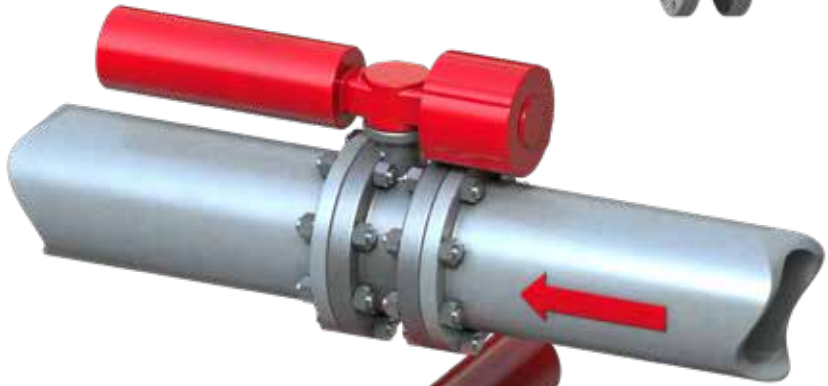

5H

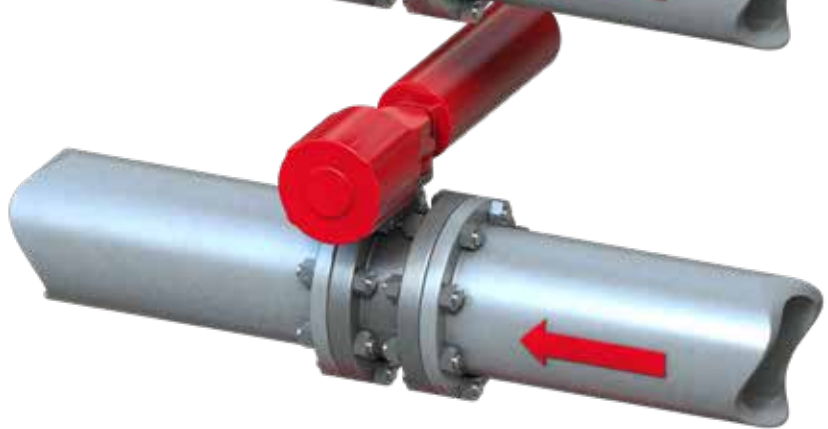

9H

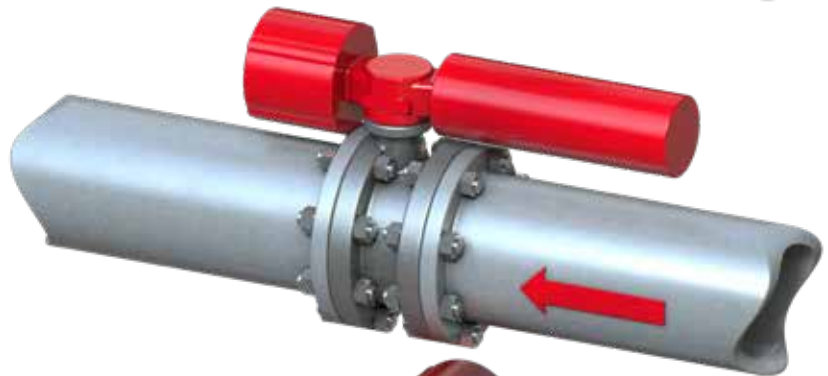

13H

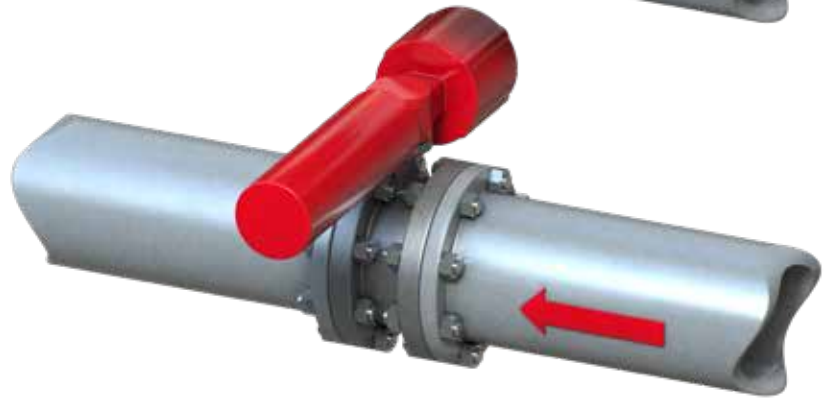

GEAR ORIENTATIONS



← Preferred Flow
stem on the upstream (Pressure Side)

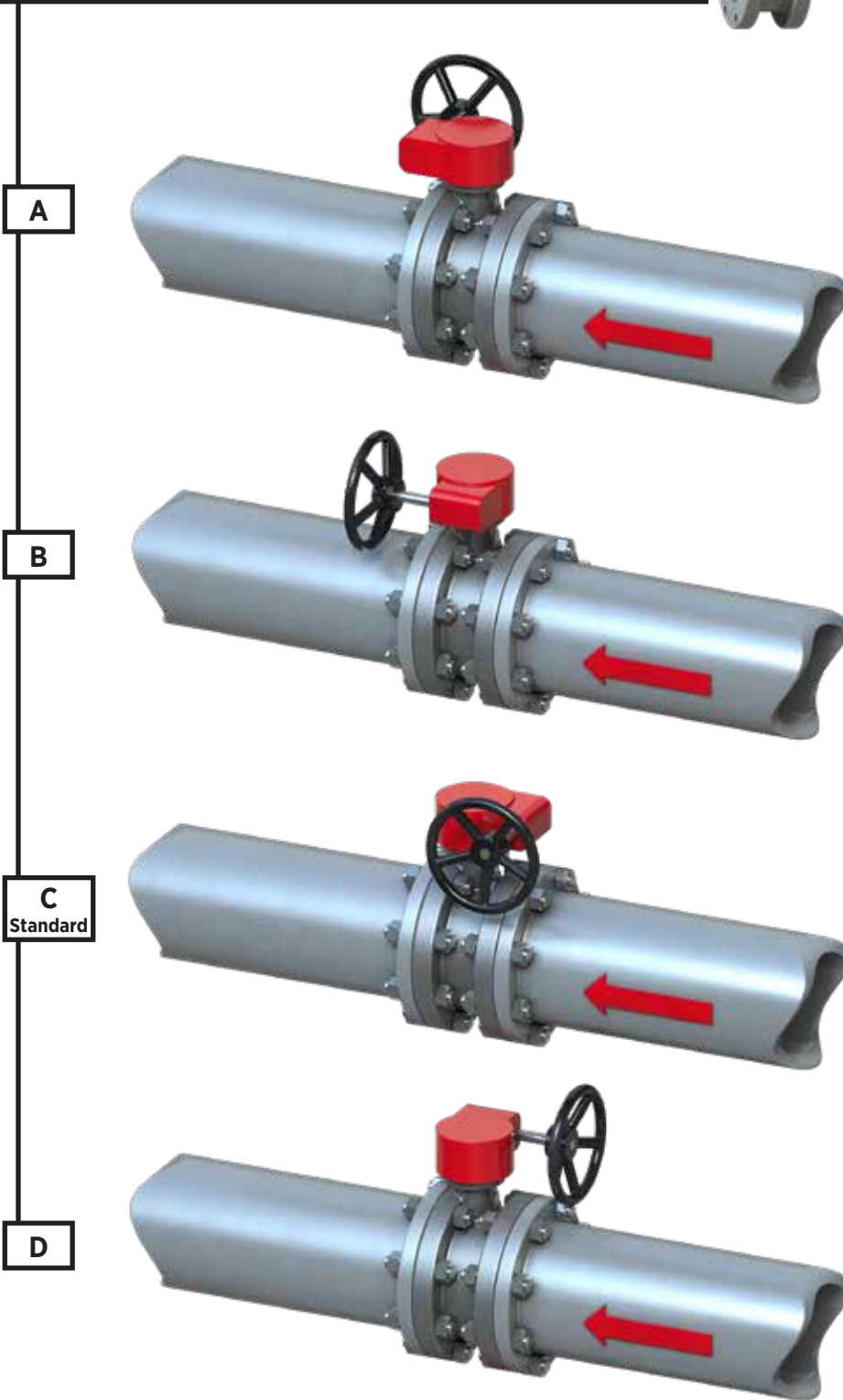

CLASS 150

OVERALL DIMENSIONS - IMPERIAL

Inches Size NPS	FACE TO FACE DIMENSIONS (in.)			Dimensions (in.)					WEIGHT (lb)				
	Wafer & Lug B	Double Flanged B	Gate B	D	E	G	H	J	Gear	Wafer	Lug	Double Flanged	Gate
3	1.88	4.50	8.00	4.27	8.40	2.05	9.45	8.00	12	17	18	34	40
4	2.12	5.00	9.00	4.68	9.15	2.05	9.45	8.00	12	22	27	45	55
6	2.25	5.50	10.50	5.85	9.90	2.05	9.45	8.00	12	36	42	67	87
8	2.50	6.00	11.50	7.12	11.15	2.05	10.53	12.00	12	57	64	104	132
10	2.81	6.50	13.00	8.66	12.40	2.63	10.86	24.00	18	94	110	159	203
12	3.19	7.00	14.00	10.23	14.22	3.53	11.52	24.00	32	132	156	232	306
14	3.62	7.50	15.00	11.44	15.97	3.53	13.41	30.00	32	200	228	325	419
16	4.00	8.50	16.00	12.75	19.72	6.06	15.08	24.00	91	303	360	498	588
18	4.50	8.75	17.00	14.48	21.97	6.06	16.45	30.00	91	449	490	633	732
20	5.00	9.00	18.00	15.48	24.72	6.06	17.45	36.00	91	551	648	777	907
24	6.06	10.50	20.00	17.18	27.10	7.28	17.26	18.00	185	886	1010	1208	1346
30	7.50	12.52	24.00	21.67	34.25	2.77	22.59	24.00	400	1660	1836	1933	2449
32	7.50	12.52	N/A	22.90	35.50	2.77	24.48	30.00	400	N/A	2298	2398	N/A
36	8.25	12.99	N/A	25.62	40.06	4.91	23.58	18.00	649	2446	2829	2978	N/A
40	9.88	16.14	N/A	28.00	44.06	4.91	24.83	24.00	649	N/A	3688	3988	N/A
42	9.88	16.14	N/A	29.76	45.06	4.91	24.83	24.00	649	3510	4140	4320	N/A
48	10.88	18.50	N/A	32.49	52.32	4.80	37.05	18.00	1753	4810	5290	5750	N/A

Notes:

1. Face to face dimensions are in strict accordance with the latest edition of the stated standards.
2. Flange/end connections are in strict accordance with ASME B16.5 or ASME B16.47.
3. Please consult your Bray Representative for available sizes, classes and end connections for table values shown as "N/A".

Lug
API 609 Table 3A

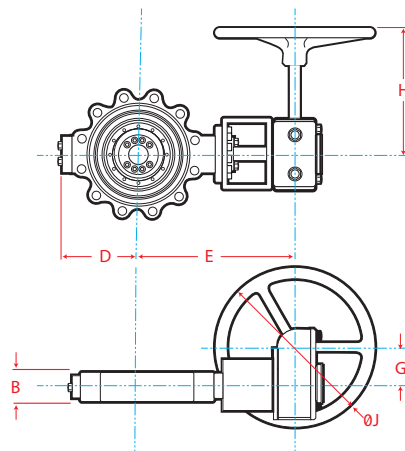

Wafer
API 609 Table 3A

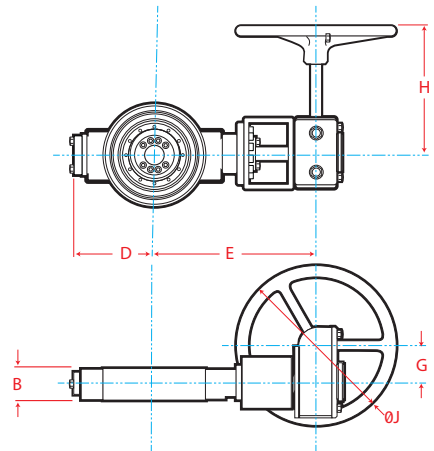

CLASS 150 OVERALL DIMENSIONS - METRIC

mm Size	FACE TO FACE DIMENSIONS (mm)			Dimensions (mm)					WEIGHT (kg)				
	Wafer & Lug	Double Flanged	Gate	D	E	G	H	J	Gear	Wafer	Lug	Double Flanged	Gate
DN	B	B	B	D	E	G	H	J					
80	48	114	203	108	213	52	240	200	6	8	8	15	18
100	54	127	229	119	233	52	240	200	6	10	12	20	25
150	57	140	267	149	252	52	240	200	6	16	19	30	39
200	64	152	292	181	283	52	267	300	6	26	29	47	60
250	71	165	330	220	315	67	276	600	8	43	50	72	92
300	81	178	356	260	361	90	293	600	15	60	71	105	139
350	92	191	381	291	406	90	341	750	15	91	103	147	190
400	102	216	406	324	501	154	383	600	41	137	163	226	267
450	114	222	432	368	558	154	418	750	41	204	222	287	332
500	127	229	457	393	628	154	443	900	41	250	294	352	411
600	154	267	508	436	688	185	438	450	84	402	458	548	611
750	191	318	610	550	870	70	574	600	182	753	833	877	1111
800	191	318	N/A	582	902	70	622	750	182	N/A	1042	1088	N/A
900	210	330	N/A	651	1018	125	599	450	294	1109	1283	1351	N/A
1000	251	410	N/A	711	1119	125	631	600	294	N/A	1673	1809	N/A
1050	251	410	N/A	756	1145	125	631	600	294	1592	1878	1960	N/A
1200	276	470	N/A	825	1329	122	941	450	795	2182	2400	2608	N/A

**Double Flanged
API 609 Table 3C
ISO 5752 Col. 13**

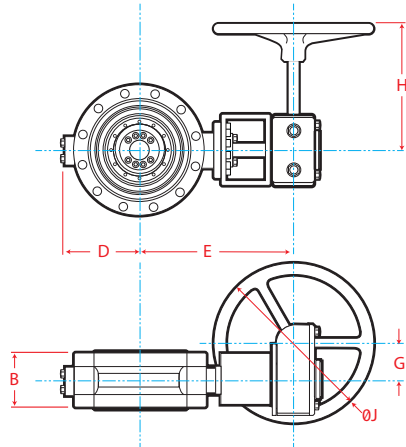

**Gate
API 609 Table 3B
ASME B16.10**

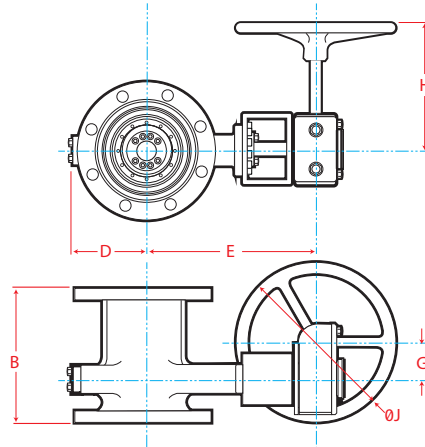

Notes:

1. Face to face dimensions are in strict accordance with the latest edition of the stated standards.
2. Flange/end connections are in strict accordance with ASME B16.5 or ASME B16.47.
3. Please consult your Bray Representative for available sizes, classes and end connections for table values shown as "N/A".

CLASS 300

OVERALL DIMENSIONS - IMPERIAL

Inches	FACE TO FACE DIMENSIONS (in.)			Dimensions (in.)					WEIGHT (lb)				
	Wafer & Lug	Double Flanged	Gate						Gear	Wafer	Lug	Double Flanged	Gate
Size	B	B	B	D	E	G	H	J					
NPS	B	B	B	D	E	G	H	J					
3	1.88	4.50	11.12	4.27	8.40	2.05	9.45	8.00	12	17	24	34	53
4	2.12	5.00	12.00	4.68	9.15	2.05	9.45	8.00	12	22	31	45	79
6	2.31	5.50	15.88	7.00	10.90	2.63	9.61	18.00	18	47	56	67	153
8	2.88	6.00	16.50	8.34	12.22	3.53	11.52	24.00	32	83	99	104	242
10	3.25	6.50	18.00	9.59	13.47	6.06	16.45	30.00	91	120	149	149	353
12	3.62	7.00	19.75	11.37	15.97	6.06	16.45	30.00	91	184	243	243	531
14	4.62	7.50	30.00	12.43	20.36	5.74	17.15	24.00	98	294	420	420	891
16	5.25	8.50	33.00	14.09	24.60	7.28	18.51	24.00	185	444	595	590	1222
18	5.88	8.75	36.00	14.94	24.60	7.28	18.51	24.00	185	589	800	800	1563
20	6.25	9.00	39.00	16.04	26.50	2.77	24.48	30.00	400	732	989	985	1939
24	7.12	10.50	45.00	18.73	30.50	2.77	22.59	24.00	400	1188	1632	1632	3022
30	9.00	12.52	N/A	23.93	40.81	4.91	24.83	24.00	649	2489	3279	2849	N/A
36	10.67	12.99	N/A	27.25	47.82	4.80	38.30	24.00	1753	3634	4958	4079	N/A
42	13.00	16.14	N/A	28.70	49.82	4.80	38.30	24.00	1753	N/A	5345	6107	N/A
48	15.00	18.50	N/A	33.24	54.82	4.80	38.30	24.00	1753	N/A	6150	7595	N/A

Notes:

1. Face to face dimensions are in strict accordance with the latest edition of the stated standards.
2. Flange/end connections are in strict accordance with ASME B16.5 or ASME B16.47.
3. Please consult your Bray Representative for available sizes, classes and end connections for table values shown as "N/A".

Lug
API 609 Table 3A

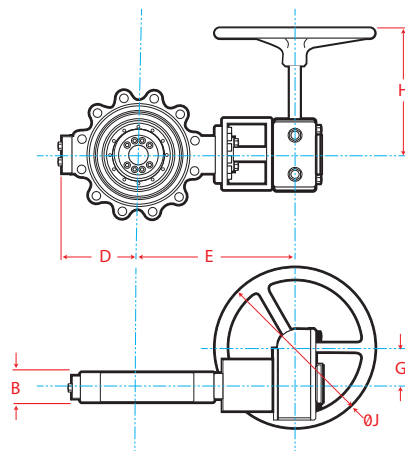

Wafer
API 609 Table 3A

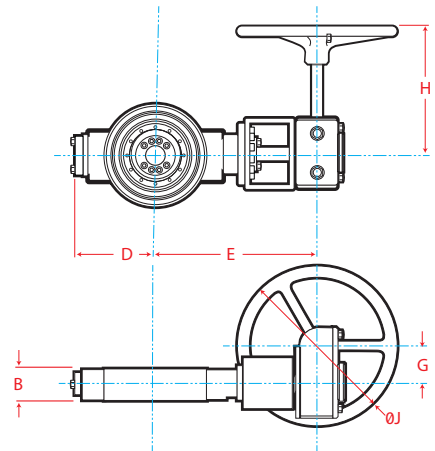

CLASS 300 **OVERALL DIMENSIONS - METRIC**

mm	FACE TO FACE DIMENSIONS (mm)			Dimensions (mm)					WEIGHT (kg)				
	Wafer & Lug	Double Flanged	Gate						Gear	Wafer	Lug	Double Flanged	Gate
Size	B	B	B	D	E	G	H	J					
DN	B	B	B	D	E	G	H	J					
80	48	114	282	108	213	52	240	200	6	8	11	15	24
100	54	127	305	132	233	52	240	200	6	10	14	20	36
150	59	140	403	178	277	67	244	450	8	21	25	30	69
200	73	152	419	212	310	90	293	600	15	38	45	47	110
250	83	165	457	244	342	154	418	750	41	54	68	68	160
300	92	178	502	289	406	154	418	750	41	83	110	110	241
350	117	191	762	316	517	146	436	600	44	133	191	191	404
400	133	216	838	358	625	185	470	600	84	201	270	268	554
450	149	222	914	379	625	185	470	600	84	267	363	363	709
500	159	229	991	407	673	70	622	750	182	332	449	447	880
600	181	267	1143	476	775	70	574	600	182	539	740	740	1371
750	229	318	N/A	608	1037	125	631	600	294	1129	1487	1293	N/A
900	271	330	N/A	692	1215	122	973	600	795	1648	2248	1850	N/A
1050	330	410	N/A	729	1265	122	973	600	795	N/A	2424	2770	N/A
1200	381	470	N/A	844	1392	122	973	600	795	N/A	2790	3445	N/A

Double Flanged
API 609 Table 3C
ISO 5752 Col. 13

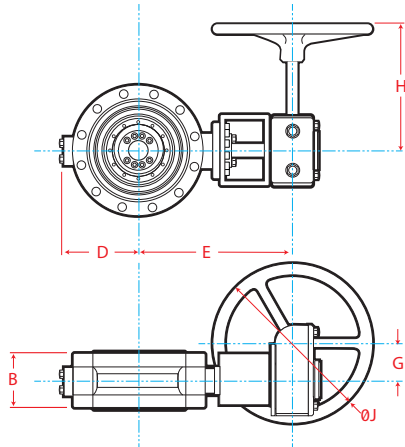

Gate
API 609 Table 3B
ASME B16.10

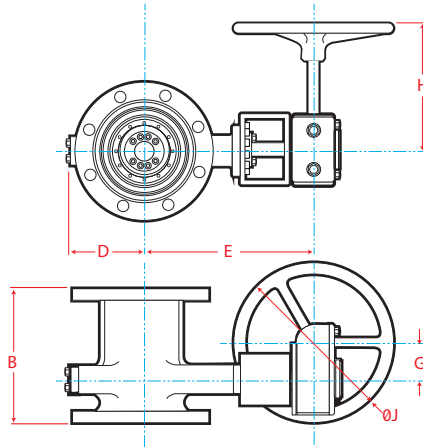

Notes:

1. Face to face dimensions are in strict accordance with the latest edition of the stated standards.
2. Flange/end connections are in strict accordance with ASME B16.5 or ASME B16.47.
3. Please consult your Bray Representative for available sizes, classes and end connections for table values shown as "N/A".

CLASS 600

OVERALL DIMENSIONS

Inches	Face to Face Dimensions (in.)	Dimensions (in.)					WEIGHT (lb)	
	Double Flanged	B	D	E	G	H	J	Gear
Size	NPS							Gear
4	7.48	6.22	15.78	2.63	8.42	10.00	18	130
6	8.27	10.00	18.15	3.54	15.71	10.00	98	240
8	9.06	11.27	19.69	3.54	15.71	14.00	98	361
10	9.84	13.62	24.65	4.24	20.70	14.00	185	638
12	10.63	14.71	26.56	2.77	22.03	14.00	400	783
14	11.42	16.00	28.13	2.77	22.03	18.00	400	987
16	12.20	17.64	30.75	2.77	23.28	24.00	400	1316
18	13.00	19.32	35.06	4.91	25.50	24.00	650	1740
20	13.78	22.01	38.29	4.91	27.00	30.00	650	2370
24	15.35	25.31	45.80	4.81	37.20	18.00	1754	3250

mm	Face to Face Dimensions (mm)	Dimensions (mm)					WEIGHT (kg)	
	Double Flanged	B	D	E	G	H	J	Gear
Size	DN							Gear
100	190	158	376	67	214	254	8	59
150	210	254	461	90	399	254	44	109
200	230	286	500	90	399	356	44	164
250	250	346	626	108	526	356	84	289
300	270	374	675	70	560	356	182	355
350	290	406	715	70	560	457	181	448
400	310	448	781	70	591	610	181	597
450	330	491	891	125	648	610	295	789
500	350	559	973	125	686	762	295	1075
600	390	643	1164	122	945	457	796	1474

Double Flanged
API 609 Table 3C , ISO 5752 Col. 14

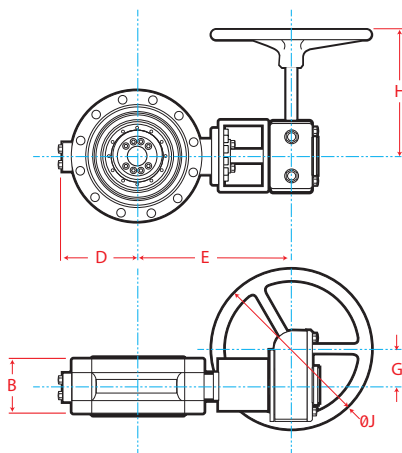

Notes:

1. Face to face dimensions are in strict accordance with the latest edition of the stated standards.
2. Flange/end connections are in strict accordance with ASME B16.5 or ASME B16.47.
3. Please consult your Bray Representative for available sizes, classes and end connections for table values shown as "N/A".

DISC PROTRUSION DIMENSIONS

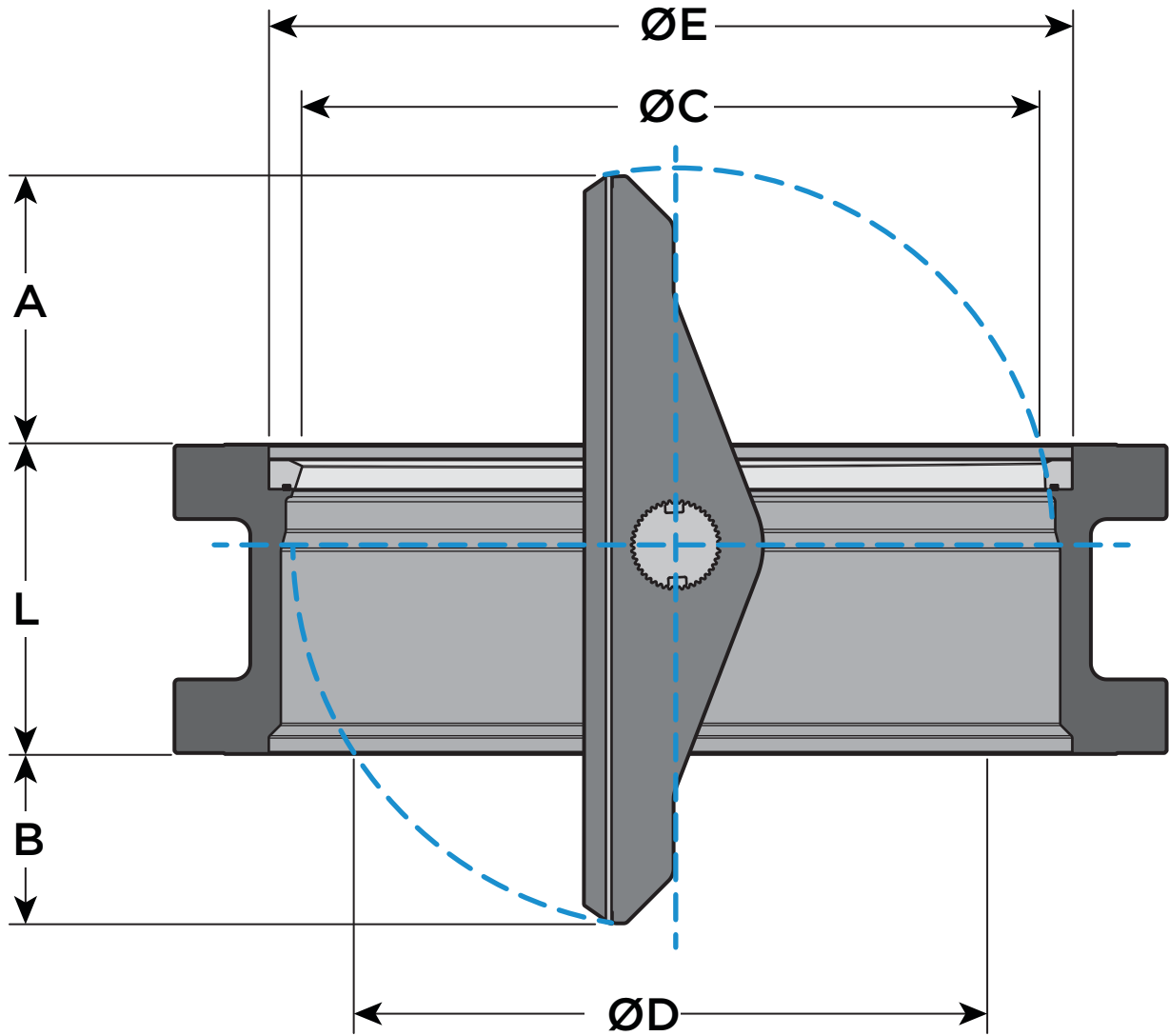

CLASS 150

DISC PROTRUSION DIMENSIONS

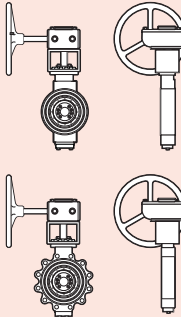
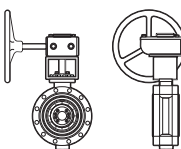
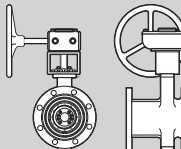
VALVE SIZE		A		B		L		ØC		ØD		ØE		
		in	mm	in	mm	in	mm	in	mm	in	mm	in	mm	
WAFER/LUG API 609 Table 3A 	3	80	0.2	4	0.5	13	2.0	50	1.1	28	2.3	58	3.8	97
	4	100	0.5	13	1.0	25	2.1	54	2.3	58	3.3	84	4.8	122
	6	150	1.4	36	1.9	48	2.3	57	4.6	117	5.3	135	6.7	170
	8	200	2.2	55	2.7	69	2.5	64	6.3	160	7.0	178	8.7	221
	10	250	3.1	78	3.6	91	2.8	71	8.3	211	8.9	226	10.9	277
	12	300	3.9	100	4.4	112	3.2	81	10.3	262	10.9	277	12.9	328
	14	350	4.3	109	4.9	124	3.6	92	11.4	290	12.1	307	14.1	358
	16	400	5.0	128	5.8	147	4.0	103	13.3	338	14.1	358	16.2	411
	18	450	5.8	146	6.5	165	4.5	115	14.9	378	15.9	404	18.2	462
	20	500	6.5	165	7.3	185	5.0	127	16.8	427	17.7	450	20.2	513
	24	600	8.3	211	8.6	218	6.1	154	20.8	528	21.5	546	24.3	617
	30	750	10.5	268	10.8	274	7.5	191	26.2	665	26.9	683	30.3	770
	32	800	11.6	295	12.0	305	7.5	191	28.3	719	29.1	739	32.3	820
	36	900	13.1	333	13.9	353	8.3	210	31.9	810	33.1	841	36.3	922
	40	1000	14.7	374	14.7	373	9.9	251	35.8	909	36.6	930	40.3	1024
	42	1050	15.7	400	15.8	401	9.9	251	37.7	958	38.7	983	42.3	1074
48	1200	18.2	462	18.7	475	10.9	276	43.5	1105	44.6	1133	48.3	1227	
DOUBLE FLANGE API 609 Table 3C, ISO 5752 COL.13 	3	80	0.2	5	0	0	4.5	114	1.1	28	0	0	3.8	97
	4	100	0.5	13	0	0	5.0	127	2.3	58	0	0	4.8	122
	6	150	1.4	36	0	0	5.5	140	4.6	117	0	0	6.7	170
	8	200	2.2	56	0	0	6.0	152	6.3	160	0	0	8.7	221
	10	250	3.1	79	0	0	6.5	165	8.3	211	0	0	10.9	277
	12	300	3.9	99	0.3	8	7.0	178	10.3	262	4.3	109	12.9	328
	14	350	4.3	109	0.7	18	7.5	191	11.4	290	6.1	155	14.1	358
	16	400	5.0	127	1.0	25	8.5	216	13.3	338	7.7	196	16.2	411
	18	450	5.8	147	2.0	51	8.8	222	14.9	378	10.6	269	18.2	462
	20	500	6.5	165	3.0	76	9.0	229	16.8	427	13.4	340	20.2	513
	24	600	8.3	211	3.9	99	10.5	267	20.8	528	16.7	424	24.3	617
	30	750	10.5	267	5.5	140	12.5	318	26.2	665	21.8	554	30.3	770
	32	800	11.6	295	6.6	168	12.5	318	28.1	714	24.4	620	32.3	820
	36	900	13.1	333	8.8	224	13.0	330	31.9	810	29.3	744	36.3	922
	40	1000	14.7	373	8.0	203	16.1	410	35.8	909	30.4	772	40.3	1024
	42	1050	15.7	399	9.1	231	16.1	410	37.7	958	33.0	838	42.3	1074
48	1200	18.6	472	10.1	257	18.5	470	43.6	1107	37.3	947	48.3	1227	
GATE API 609 Table 3B, ASME B16.10 	3	80	0	0	0	0	8.0	203	0	0	0	0	3.8	97
	4	100	0.1	3	0	0	9.0	229	1.0	25	0	0	4.8	122
	6	150	0.1	3	0	0	10.5	267	1.4	36	0	0	6.7	170
	8	200	0.1	3	0	0	11.5	292	1.7	43	0	0	8.7	221
	10	250	0.1	3	0	0	13.0	330	1.9	48	0	0	10.9	277
	12	300	0.1	3	0	0	14.0	356	2.3	58	0	0	12.9	328
	14	350	0.1	3	0	0	15.0	381	2.4	61	0	0	14.2	361
	16	400	0.2	5	0	0	16.0	406	2.9	74	0	0	16.2	411
	18	450	0.2	5	0	0	17.0	432	3.1	79	0	0	18.2	462
	20	500	0.2	5	0	0	18.0	457	3.3	84	0	0	20.2	513
24	600	2.0	51	0	0	20	508	12.2	310	0	0	24.3	617	
30	750	3.7	94	0	0	24.0	610	18.1	460	0	0	30.3	770	

Valves listed are for maximum protrusion, due to offsets disc may or may not be at 90° angle for this to occur.
 "0" indicates no protrusion beyond flange face. Consult your Bray Representative for Sizes and ASME Classes Not Listed.

CLASS 300

DISC PROTRUSION DIMENSIONS

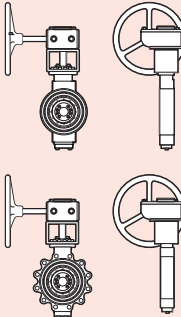
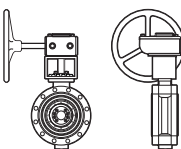
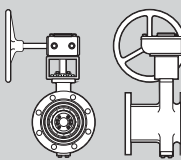
	VALVE SIZE		A		B		L		ØC		ØD		ØE	
	in	mm	in	mm	in	mm	in	mm	in	mm	in	mm	in	mm
WAFER/LUG API 609 Table 3A 	3	80	0.2	5	0.5	13	2.1	53	1.2	30	2.5	64	4.1	104
	4	100	0.5	13	1.0	25	2.3	58	2.5	64	3.6	91	5.2	132
	6	150	1.2	30	1.8	46	2.5	64	4.5	114	5.4	137	7.2	183
	8	200	1.8	46	2.4	61	3.1	79	6.4	163	7.3	185	9.4	239
	10	250	2.7	69	3.4	86	3.5	89	8.7	221	9.6	244	11.7	297
	12	300	3.6	91	4.3	109	3.9	99	10.8	274	11.7	297	13.8	351
	14	350	3.8	97	4.1	104	5.0	127	11.8	300	12.4	315	15.2	386
	16	400	4.5	114	4.8	122	5.6	142	13.8	351	14.6	371	17.4	442
	18	450	5.3	135	5.5	140	6.3	160	15.8	401	16.4	417	19.5	495
	20	500	6.1	155	6.3	160	6.7	170	17.8	452	18.4	467	21.7	551
	24	600	7.7	196	8.0	203	7.7	196	21.9	556	22.7	577	26.1	663
	30	750	9.8	249	10.1	257	9.7	246	28.0	711	28.7	729	32.5	826
36	900	11.8	300	12.5	318	11.5	292	33.5	851	35.0	889	36.7	932	
42	1050	14.3	363	13.7	348	14.0	356	39.6	1006	40.3	1024	43.2	1097	
48	1200	16.5	419	15.7	399	16.1	409	45.6	1158	46.4	1179	49.6	1260	
DOUBLE FLANGE API 609 Table 3C, ISO 5752 COL.13 	3	80	0.2	5	0	0	4.8	122	1.2	30	0	0	4.1	104
	4	100	0.5	13	0	0	5.4	137	2.5	64	0	0	5.2	132
	6	150	1.2	30	0	0	5.9	150	4.5	114	0	0	7.2	183
	8	200	1.8	46	0	0	6.4	163	6.4	163	0	0	9.4	239
	10	250	2.7	69	0	0	7.0	178	8.7	221	0	0	11.7	297
	12	300	3.6	91	0.7	18	7.5	191	10.8	274	6.2	157	13.8	351
	14	350	3.8	97	1.0	25	8.1	206	11.8	300	7.7	196	15.2	386
	16	400	4.5	114	1.4	36	9.1	231	13.8	351	9.4	239	17.4	442
	18	450	5.3	135	2.4	61	9.4	239	15.8	401	12.5	318	19.5	495
	20	500	6.1	155	3.4	86	9.7	246	17.7	450	15.2	386	21.7	551
	24	600	7.7	196	4.3	109	11.3	287	21.9	556	18.8	478	26.1	663
	30	750	9.8	249	6.3	160	13.5	343	28.0	711	25.0	635	32.5	826
36	900	11.8	300	10	254	14.0	356	33.5	851	33.0	838	39.0	991	
42	1050	14.3	363	10.3	262	17.4	442	39.6	1006	37.1	942	45.4	1153	
48	1200	16.5	419	12.0	305	19.9	505	45.6	1158	42.9	1090	51.9	1318	
GATE API 609 Table 3B, ASME B16.10 	3	80	0	0	0	0	12.0	305	0	0	0	0	4.1	104
	4	100	0.1	3	0	0	12.9	328	1.1	28	0	0	5.2	132
	6	150	0	0	0	0	17.1	434	0	0	0	0	7.2	183
	8	200	0	0	0	0	17.7	450	0	0	0	0	9.4	239
	10	250	0	0	0	0	19.4	493	0	0	0	0	11.7	297
	12	300	0	0	0	0	21.2	538	0	0	0	0	13.8	351
	14	350	0	0	0	0	32.3	820	0	0	0	0	15.2	386
	16	400	0	0	0	0	35.5	902	0	0	0	0	17.4	442
18	450	0	0	0	0	38.7	983	0	0	0	0	19.5	495	
20	500	0.3	8	0	0	41.9	1064	4.7	119	0	0	21.7	551	
24	600	0.3	8	0	0	48.4	1229	5.3	135	0	0	26.1	663	

Valves listed are for maximum protrusion, due to offsets disc may or may not be at 90° angle for this to occur.
 "0" indicates no protrusion beyond flange face. Consult your Bray Representative for Sizes and ASME Classes Not Listed.

CLASS 600

DISC PROTRUSION DIMENSIONS

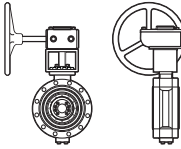
	VALVE SIZE		A		B		L		ØC		ØD		ØE	
	in	mm	in	mm	in	mm	in	mm	in	mm	in	mm	in	mm
<p>DOUBLE FLANGE API 609 Table 3C, ISO 5752 COL.14</p> 	4	100	0	0	0	0	7.48	190	0	0	0	0	4.62	117
	6	150	0	0	0	0	8.27	210	0	0	0	0	6.72	171
	8	200	0	0	0	0	9.06	230	0	0	0	0	8.72	221
	10	250	0	0	0	0	9.84	250	0	0	0	0	10.75	273
	12	300	0.1	2	0.5	13	10.63	270	4.25	108	5.0	127	12.75	324
	14	350	0.3	7	0.7	18	11.42	290	5.85	149	6.2	157	14.14	359
	16	400	0.7	17	1.1	28	12.20	310	8.00	203	8.1	206	16.16	410
	18	450	1.3	33	1.7	42	13.00	330	10.10	257	10.3	262	18.18	462
	20	500	1.7	43	2.3	58	13.78	350	12.10	307	12.3	312	20.2	513
24	600	2.6	65	3.3	84	15.35	390	15.46	393	15.72	399	24.25	616	

Valves listed are for maximum protrusion, due to offsets disc may or may not be at 90° angle for this to occur.
 "0" indicates no protrusion beyond flange face. Consult your Bray Representative for Sizes and ASME Classes Not Listed.

FLOW CAPACITY (Cv/Kv)

Rated Cv/Kv Chart for Tri Lok Valves at Full Open Position

VALVE SIZE		CLASS 150				CLASS 300				CLASS 600			
in	mm	Preferred (Shaft Side) Curve 1		Non-Preferred (Disc Side) Curve 2		Preferred (Shaft Side) Curve 1		Non-Preferred (Disc Side) Curve 2		Preferred (Shaft Side) Curve 1		Non-Preferred (Disc Side) Curve 2	
		Cv	Kv	Cv	Kv	Cv	Kv	Cv	Kv	Cv	Kv	Cv	Kv
3	80	95	82	81	70	95	82	81	70	N/A	N/A	N/A	N/A
4	100	124	107	119	103	124	107	119	103	89	77	80	69
6	150	485	420	413	357	475	411	398	344	445	385	432	374
8	200	1,127	975	989	855	1,105	956	950	822	681	589	647	560
10	250	2,605	2,253	2,215	1,916	1,870	1,618	1,758	1,521	1,177	1,018	1,195	1,034
12	300	3,515	3,040	3,281	2,838	2,862	2,476	2,696	2,332	2,128	1,841	1,974	1,708
14	350	5,542	4,794	4,711	4,075	4,145	3,585	3,911	3,383	2,864	2,477	2,854	2,469
16	400	6,548	5,664	5,566	4,815	5,626	4,866	5,329	4,610	3,597	3,111	3,613	3,125
18	450	8,218	7,109	6,986	6,043	7,413	6,412	6,850	5,925	4,933	4,267	4,858	4,202
20	500	10,805	9,346	9,184	7,944	9,396	8,128	9,032	7,813	5,838	5,050	5,859	5,068
24	600	16,542	14,309	15,964	13,809	14,357	12,419	13,670	11,825	9,059	7,836	8,522	7,372
30	750	26,183	22,648	25,054	21,672	24,269	20,993	23,222	20,087	14,523	12,562	13,906	12,029
32	800	29,791	25,769	28,550	24,696	28,172	24,369	26,998	23,353	N/A	N/A	N/A	N/A
36	900	37,967	32,841	36,492	31,566	32,139	27,800	30,847	26,683	19,998	17,298	19,996	17,297
40	1000	46,872	40,544	45,177	39,078	40,586	35,106	39,065	33,791	N/A	N/A	N/A	N/A
42	1050	51,643	44,671	49,842	43,113	45,250	39,141	43,614	37,726	N/A	N/A	N/A	N/A
48	1200	67,797	58,644	65,676	56,810	60,487	52,321	58,524	50,623	N/A	N/A	N/A	N/A

- 1) To find Cv at varying opening angles, use curves specified in heading.
- 2) Please contact your Bray Representative for valves shown as "N/A".

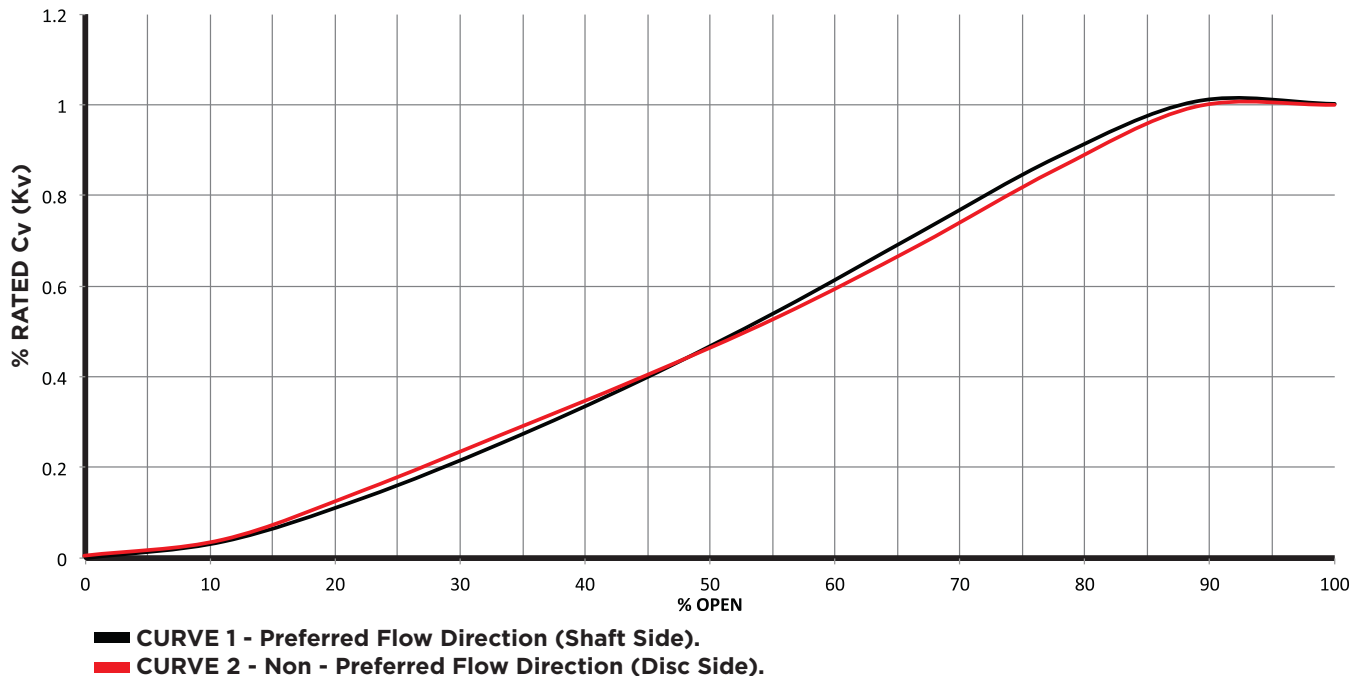

PRESSURE TEMPERATURE RATING CHARTS

Body Material ASTM A216 WCB

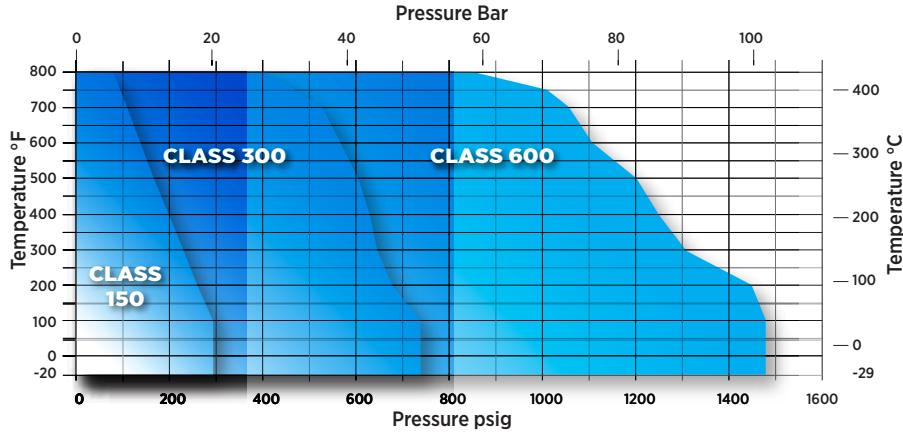

Body Material ASTM A351 CF8M

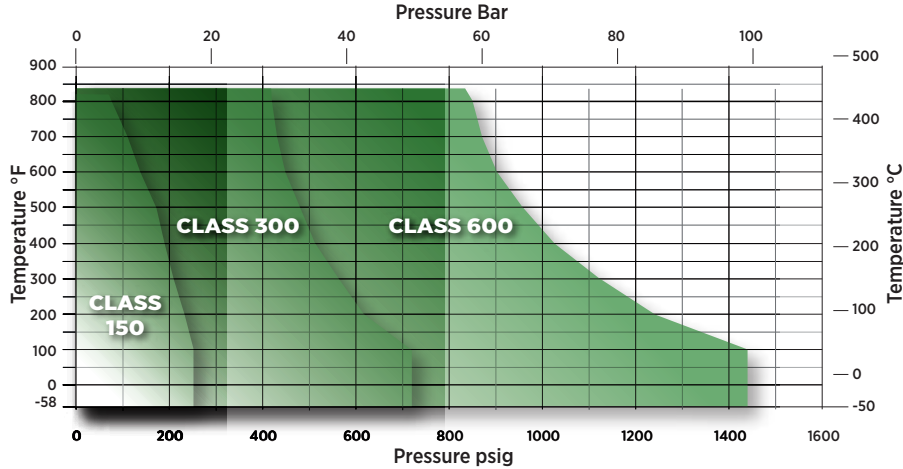

Body Material ASTM A352 LCB

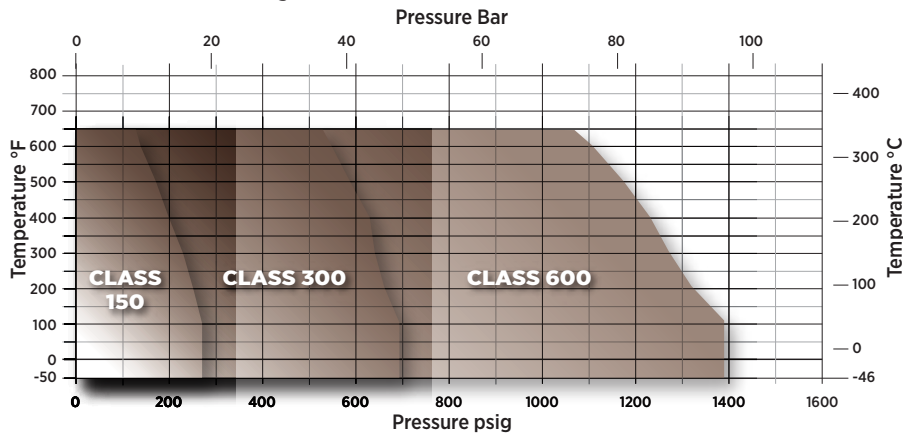

Ratings correspond to ASME B16.34 for material grades shown

ASTM A216 WCB PRESSURE TEMPERATURE RATING TABLE

Body Material		Applicable Rating Standard		Material Group		Min Design Temp	
ASTM A216 WCB ²		ASME B16.34		1.1		-20°F (-29°C)	
Design Temperature		ASME Pressure Class					
		Class 150		Class 300		Class 600	
		Maximum Allowable Pressure ¹					
°C	°F	barg	psig	barg	psig	barg	psig
-29 to 38	-20 to 100	19.6	285	51.1	740	102.1	1,480
50	122	19.2	278	50.1	727	100.2	1,453
93	200	17.9	260	46.9	680	93.8	1,360
100	212	17.7	257	46.6	676	93.2	1,352
149	300	15.9	230	45.2	655	90.3	1,310
150	302	15.8	229	45.1	654	90.2	1,308
200	392	13.8	200	43.8	635	87.6	1,271
204	400	13.8	200	43.8	635	87.2	1,265
250	482	12.1	175	41.9	608	83.9	1,217
260	500	11.7	170	41.7	605	83.1	1,205
300	572	10.2	148	39.8	577	79.6	1,155
315 ³	600 ³	9.7	140	39.3	570	78.3	1,135
325	617	9.3	135	38.7	561	77.4	1,123
343	650	8.6	125	37.9	550	75.8	1,100
350	662	8.4	122	37.6	545	75.1	1,089
371	700	7.6	110	36.5	530	73.1	1,060
375	707	7.4	107	36.4	528	72.7	1,054
399	750	6.6	95	34.8	505	70.0	1,015
400	752	6.5	94	34.7	503	69.4	1,007
425	797	5.5	80	28.8	418	57.5	834
427	800	5.5	80	28.3	410	56.9	825

NOTES:

1. Maximum allowable pressure at selected design temperature refers to valve body material. There may be further temperature limitations based on valve trim and application conditions.
2. Minimum application temperature of ASTM A216 WCB is defined by ASME B16.34. Some codes or regulations, such as EU Directive 2014/68/EU PED, may restrict minimum temperature to higher than -20°F (-29°C). When such requirements apply, it is the responsibility of the purchaser to ensure these requirements are communicated to Bray prior to the time of purchase.
3. Stem - ASTM A564-Type 630 Condition H1 150D (17-4 PH) not suitable for use above 600°F (315°C). For services above 600°F (315°C) factory generally suggests use of ASTM A182 F6A Cl 3. For temperatures over 800°F (427°C) please consult factory.

ASTM A351 CF8M PRESSURE TEMPERATURE RATING TABLE

Body Material		Applicable Rating Standard		Material Group		Min Design Temp	
ASTM A351 CF8M		ASME B16.34		2.2		-58°F (-50°C)	
Design Temperature		ASME Pressure Class					
		Class 150		Class 300		Class 600	
		Maximum Allowable Pressure ¹					
°C	°F	barg	psig	barg	psig	barg	psig
-50 to 38	-58 to 100	19.0	275	49.6	720	99.3	1,440
50	122	18.4	267	48.1	698	96.2	1,395
93	200	16.2	235	42.7	620	85.5	1,240
100	212	16.2	235	42.2	612	84.4	1,224
149	300	14.8	215	38.6	560	77.2	1,120
150	302	14.8	215	38.5	558	77.0	1,117
200	392	13.7	199	35.7	518	71.3	1,034
204	400	13.4	195	35.5	515	70.7	1,025
250	482	12.1	175	33.4	484	66.8	969
260	500	11.7	170	33.1	480	65.8	955
300	572	10.2	148	31.6	458	63.2	917
315 ²	600 ²	9.7	140	31.0	450	62.1	900
325	617	9.3	135	30.9	448	61.8	896
343	650	8.6	125	30.3	440	61.0	885
350	662	8.4	122	30.3	439	60.7	880
371	700	7.6	110	30.0	435	60.0	870
375	707	7.4	107	29.9	434	59.8	867
399	750	6.6	95	29.3	425	59.0	855
400	752	6.5	94	29.4	425	58.9	854
425	797	5.5	80	29.1	422	58.3	846
427	800	5.5	80	29.0	420	58.3	845
450	842	4.6	67	28.8	420	57.7	837

NOTES:

1. Maximum allowable pressure at selected design temperature refers to valve body material. There may be further temperature limitations based on valve trim and application conditions.
2. Stem - ASTM A564-Type 630 Condition H1150D (17-4 PH) not suitable for use above 600°F (315°C). For services above 600°F (315°C) factory generally suggests use of ASTM A182 F6A Cl 3. For temperatures over 842°F (450°C) or under -58°F (50°C) please consult factory.

ASTM A352 LCB

PRESSURE TEMPERATURE RATING TABLE

Body Material		Applicable Rating Standard		Material Group		Min Design Temp	
ASTM A352 LCB ²		ASME B16.34		1.3		-50°F (-46°C)	
Design Temperature		ASME Pressure Class					
		Class 150		Class 300		Class 600	
		Maximum Allowable Pressure ¹					
°C	°F	barg	psig	barg	psig	barg	psig
-46 to 38	-50 to 100	18.4	265	48.0	695	96.0	1,395
50	122	18.2	264	47.5	689	94.9	1,376
93	200	17.6	255	45.5	660	91.0	1,320
100	212	17.4	252	45.3	657	90.7	1,315
149	300	15.9	230	44.1	640	87.9	1,275
150	302	15.8	229	43.9	637	87.9	1,275
200	392	13.8	200	42.5	616	85.1	1,234
204	400	13.8	200	42.4	615	84.8	1,230
250	482	12.1	175	40.8	592	81.6	1,184
260	500	11.7	170	40.3	585	81.0	1,175
300	572	10.2	148	38.7	561	77.4	1,123
315 ³	600 ³	9.7	140	37.9	550	76.2	1,105
325	617	9.3	135	37.6	545	75.2	1,091
345	650	8.6	125	36.9	535	73.4	1,065

NOTES:

1. Maximum allowable pressure at selected design temperature refers to valve body material. There may be further temperature limitations based on valve trim and application conditions.
2. Per ASME B16.34, not to be used over 650°F (345°C).
3. Stem - ASTM A564-Type 630 Condition H1150D (17-4 PH) not suitable for use above 600°F (315°C). For services above 600°F (315°C) factory generally suggests use of ASTM A182 F6A Cl 3.

Examples of Typical Flange to Valve Bolting

When bolting the valve into the line, use standard bolting torque as recommended by applicable piping standards. The valve body seat is independent of the flange bolting. Additional force from the flange bolts is not required. Minimum bolt engagement must be equal to diameter of bolt.

CAUTION: To ensure proper installation refer to appropriate table within this guide for specific valve drilling information.

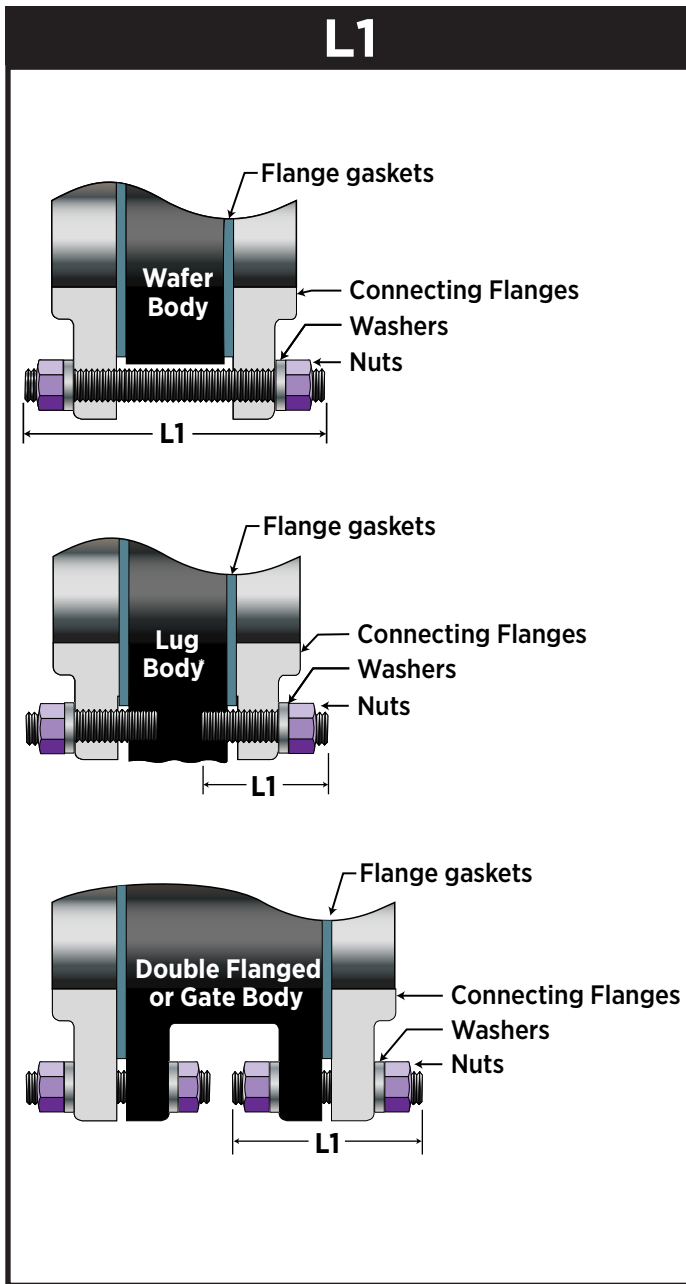

* Lug Threads may be tapped from both sides and therefore tap may not be continuous.

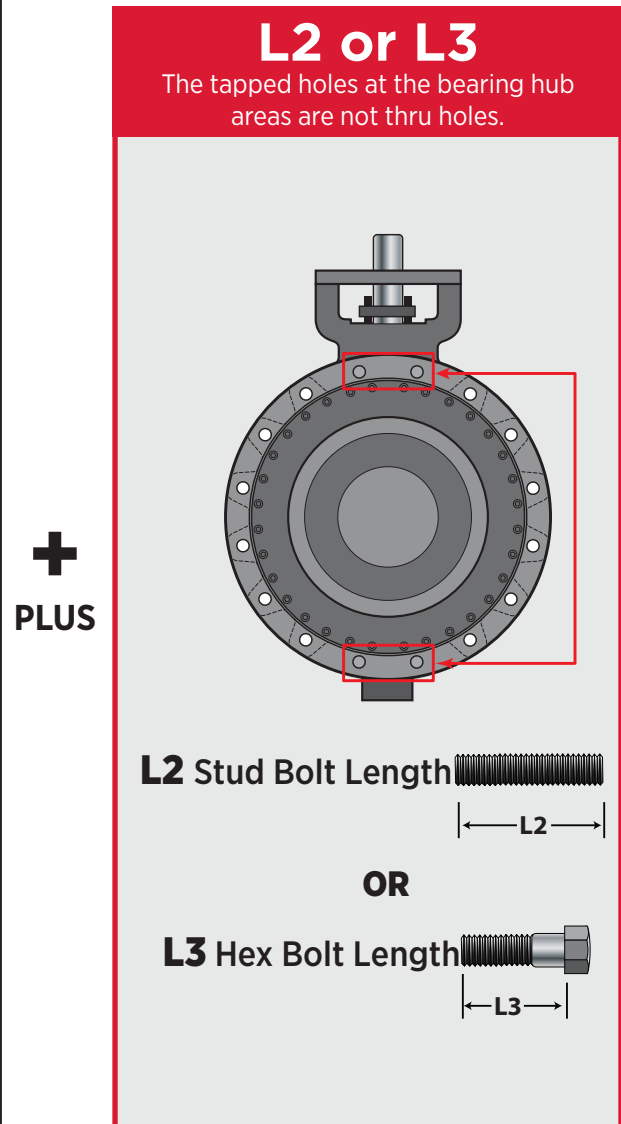

CLASS 150 | WAFER - Face to Face API 609, ISO 5752 Basic Series 13 | Body Drilling ASME B16.5

VALVE SIZE		Fastener Size	Stud Bolts & Hex Nuts - L1				Stud Bolts - L2				Qty Nuts	Hex Head Bolts - L3		
In	mm		In	mm	Qty Studs	Qty Nuts	In	mm	Qty	In		mm	Qty Bolts	
3	80	5/8" - 11 UNC	6	152	4	8	N/A	N/A	N/A	N/A	N/A	N/A	N/A	
4	100	5/8" - 11 UNC	6	152	8	16	N/A	N/A	N/A	N/A	N/A	N/A	N/A	
6	150	3/4" - 10 UNC	6.5	165	8	16	N/A	N/A	N/A	N/A	N/A	N/A	N/A	
8	200	3/4" - 10 UNC	7	178	8	16	N/A	N/A	N/A	N/A	N/A	N/A	N/A	
10	250	7/8" - 9 UNC	7.75	197	12	24	N/A	N/A	N/A	N/A	N/A	N/A	N/A	
12	300	7/8" - 9 UNC	8.25	210	12	24	N/A	N/A	N/A	N/A	N/A	N/A	N/A	
14	350	1" - 8 UNC	9.25	235	12	24	N/A	N/A	N/A	N/A	N/A	N/A	N/A	
16	400	1" - 8 UNC	9.75	248	16	32	N/A	N/A	N/A	N/A	N/A	N/A	N/A	
18	450	1 1/8" - 8 UN	10.75	273	16	32	N/A	N/A	N/A	N/A	N/A	N/A	N/A	
20	500	1 1/8" - 8 UN	11.5	292	16	32	N/A	N/A	N/A	N/A	N/A	N/A	N/A	
24	600	1 1/4" - 8 UN	13	330	16	32	4.25	108	8	8	3	76	8	
							5	127	8	8	3.5	89	8	

CLASS 150 | WAFER - Face to Face API 609, ISO 5752 Basic Series 13 | Body Drilling ASME B16.47 Series A

VALVE SIZE		Fastener Size	Stud Bolts & Hex Nuts - L1				Stud Bolts - L2				Qty Nuts	Hex Head Bolts - L3		
In	mm		In	mm	Qty Studs	Qty Nuts	In	mm	Qty	In		mm	Qty Bolts	
30	750	1 1/4" - 8 UN	16.75	425	24	48	6	152	8	8	OR	4.75	121	8
32	800	1 1/2" - 8 UN	18	457	24	48	6.75	171	8	8		5	127	8
36	900	1 1/2" - 8 UN	19.5	495	28	56	7	178	8	8		5.5	140	8
40	1000	1 1/2" - 8 UN	21	533	32	64	7.5	191	8	8		5.75	146	8
42	1050	1 1/2" - 8 UN	21.5	546	32	64	7.5	191	8	8		6	152	8
48	1200	1 1/2" - 8 UN	23.25	591	40	80	8.5	216	8	8		7	178	8

CLASS 150 | WAFER - Face to Face API 609, ISO 5752 Basic Series 13 | Body Drilling ASME B16.47 Series B

VALVE SIZE		Fastener Size	Stud Bolts & Hex Nuts - L1				Stud Bolts - L2				Qty Nuts	Hex Head Bolts - L3		
In	mm		In	mm	Qty Studs	Qty Nuts	In	mm	Qty	In		mm	Qty Bolts	
30	750	3/4" - 8 UNC	CF	CF	CF	CF	CF	CF	CF	CF	OR	CF	CF	CF
32	800	3/4" - 8 UNC	CF	CF	CF	CF	CF	CF	CF	CF		CF	CF	CF
36	900	7/8" - 8 UNC	CF	CF	CF	CF	CF	CF	CF	CF		CF	CF	CF
40	1000	1" - 8 UNC	CF	CF	CF	CF	CF	CF	CF	CF		CF	CF	CF
42	1050	1" - 8 UNC	CF	CF	CF	CF	CF	CF	CF	CF		CF	CF	CF
48	1200	1" - 8 UNC	CF	CF	CF	CF	CF	CF	CF	CF		CF	CF	CF

NOTES:

- Calculations include 2 washers (.2") for thru stud bolts and 1 washer (.1") for hex bolt and stud bolts/nut.
- Any combination of the above fastener types is applicable.
- All nuts are in accordance with ASME B18.2.2 Table 9 Heavy Hex nuts.
- All Studs are in accordance with ASME B18.2.1.
- All Stud and bolt lengths rounded to next 1/4".
- Standard gaskets (0.125"), one per side, have been included in the bolting calculations.
- Please Consult Factory for fields marked "CF".
- All fields with "N/A" indicate where the bolting requirements are not applicable.

CLASS 150 | LUG - Face to Face API 609, ISO 5752 Basic Series 13 | Body Drilling ASME B16.5

VALVE SIZE		Fastener Size	Stud Bolts & Hex Nuts - L1				Stud Bolts - L2				Hex Head Bolts - L3		
In	mm		In	mm	Qty Studs	Qty Nuts	In	mm	Qty	Qty Nuts	In	mm	Qty Bolts
3	80	5/8" - 11 UNC	3	76	8	8	N/A	N/A	N/A	N/A	N/A	N/A	N/A
4	100	5/8" - 11 UNC	3.25	83	16	16	N/A	N/A	N/A	N/A	N/A	N/A	N/A
6	150	3/4" - 10 UNC	3.25	83	16	16	N/A	N/A	N/A	N/A	N/A	N/A	N/A
8	200	3/4" - 10 UNC	3.75	95	16	16	N/A	N/A	N/A	N/A	N/A	N/A	N/A
10	250	7/8" - 9 UNC	4	102	24	24	N/A	N/A	N/A	N/A	N/A	N/A	N/A
12	300	7/8" - 9 UNC	4.25	108	24	24	N/A	N/A	N/A	N/A	N/A	N/A	N/A
14	350	1" - 8 UNC	4.75	121	24	24	N/A	N/A	N/A	N/A	N/A	N/A	N/A
16	400	1" - 8 UNC	4.5	114	32	32	N/A	N/A	N/A	N/A	N/A	N/A	N/A
18	450	1 1/8" - 8 UN	5.25	133	32	32	N/A	N/A	N/A	N/A	N/A	N/A	N/A
20	500	1 1/8" - 8 UN	5.25	133	32	32	N/A	N/A	N/A	N/A	N/A	N/A	N/A
24	600	1 1/4" - 8 UN	6	152	32	32	4	102	8	8	2.75	70	8
							5	127	8	8	3.5	89	8

CLASS 150 | LUG - Face to Face API 609, ISO 5752 Basic Series 13 | Body Drilling ASME B16.47 Series A

VALVE SIZE		Fastener Size	Stud Bolts & Hex Nuts - L1				Stud Bolts - L2				Hex Head Bolts - L3		
In	mm		In	mm	Qty Studs	Qty Nuts	In	mm	Qty	Qty Nuts	In	mm	Qty Bolts
30	750	1 1/4" - 8 UN	6.75	171	48	48	6	152	8	8	4.75	121	8
32	800	1 1/2" - 8 UN	7.75	197	48	48	6.5	165	8	8	5	127	8
36	900	1 1/2" - 8 UN	8.5	216	56	56	7	178	8	8	5.25	133	8
40	1000	1 1/2" - 8 UN	8.25	210	64	64	7.25	184	8	8	5.5	140	8
42	1050	1-1/2" - 8 UN	8.5	216	64	64	7.5	191	8	8	5.75	146	8
48	1200	1 1/2" - 8 UN	8.5	216	88	88	N/A	N/A	N/A	N/A	6.5	165	N/A

CLASS 150 | LUG - Face to Face API 609, ISO 5752 Basic Series 13 | Body Drilling ASME B16.47 Series B

VALVE SIZE		Fastener Size	Stud Bolts & Hex Nuts - L1				Stud Bolts - L2				Hex Head Bolts - L3		
In	mm		In	mm	Qty Studs	Qty Nuts	In	mm	Qty	Qty Nuts	In	mm	Qty Bolts
30	750	3/4" - 8 UNC	5	127	80	80	4	102	8	8	3	76	8
32	800	3/4" - 8 UNC	CF	CF	CF	CF	CF	CF	CF	CF	CF	CF	CF
36	900	7/8" - 8 UNC	5.5	140	80	80	4.5	114	8	8	3.5	89	8
40	1000	1" - 8 UNC	CF	CF	CF	CF	CF	CF	CF	CF	CF	CF	CF
42	1050	1" - 8 UNC	6.5	165	88	88	5.5	140	8	8	4.5	114	8
48	1200	1" - 8 UNC	6.5	165	80	80	6	152	8	8	4.75	121	8

NOTES:

- Calculations include 2 washers (.2") for thru stud bolts and 1 washer (.1") for hex bolt and stud bolts/nut.
- Any combination of the above fastener types is applicable.
- All nuts are in accordance with ASME B18.2.2 Table 9 Heavy Hex nuts.
- All Studs are in accordance with ASME B18.2.1.
- All Stud and bolt lengths rounded to next 1/4".
- Standard gaskets (0.125"), one per side, have been included in the bolting calculations.
- Please Consult Factory for fields marked "CF".
- All fields with "N/A" indicate where the bolting requirements are not applicable.

CLASS 150 | DOUBLE FLANGE - Face to Face API 609, ISO 5752 Basic Series 13 | Body Drilling ASME B16.5

VALVE SIZE		Fastener Size	Stud Bolts & Hex Nuts - L1				Stud Bolts - L2				Hex Head Bolts - L3		
In	mm		In	mm	Qty Studs	Qty Nuts	In	mm	Qty	Qty Nuts	In	mm	Qty Bolts
3	80	5/8" - 11 UNC	4	102	8	16	N/A	N/A	N/A	N/A	N/A	N/A	N/A
4	100	5/8" - 11 UNC	4	102	12	24	3	76	4	4	2.25	57	4
6	150	3/4" - 10 UNC	4.25	108	12	24	3.25	82	4	4	2.25	57	4
8	200	3/4" - 10 UNC	4.5	114	12	24	3.5	89	4	4	2.5	63	4
10	250	7/8" - 9 UNC	5	127	20	40	3.5	89	4	4	2.5	63	4
12	300	7/8" - 9 UNC	5	127	20	40	3.75	95	4	4	2.75	70	4
14	350	1" - 8 UNC	5.5	140	20	40	4.25	108	4	4	3	76	4
16	400	1" - 8 UNC	5.75	146	28	56	4.5	114	4	4	3.25	82	4
18	450	1 1/8" - 8 UN	6	152	28	56	4.5	114	4	4	3.25	82	4
20	500	1 1/8" - 8 UN	6.25	159	36	72	4.25	108	4	4	3	76	4
24	600	1 1/4" - 8 UN	7	179	36	72	5	127	4	4	3.5	89	4

CLASS 150 | DOUBLE FLANGE - Face to Face API 609, ISO 5752 Basic Series 13 | Body Drilling ASME B16.47 Series A

VALVE SIZE		Fastener Size	Stud Bolts & Hex Nuts - L1				Stud Bolts - L2				Hex Head Bolts - L3		
In	mm		In	mm	Qty Studs	Qty Nuts	In	mm	Qty	Qty Nuts	In	mm	Qty Bolts
30	750	1 1/4" - 8 UN	9.25	235	52	104	6	152	4	4	4.75	121	4
32	800	1 1/2" - 8 UN	10.25	260	48	96	6.75	171	8	8	5	127	8
36	900	1 1/2" - 8 UN	11	279	52	104	7	179	12	12	5.5	140	12
40	1000	1 1/2" - 8 UN	CF	CF	CF	CF	CF	CF	CF	CF	CF	CF	CF
42	1050	1 1/2" - 8 UN	11.5	292	62	124	7.5	190	10	10	5.75	146	10
48	1200	1 1/2" - 8 UN	12.25	311	72	144	8	203	16	16	6.25	159	16

CLASS 150 | DOUBLE FLANGE - Face to Face API 609, ISO 5752 Basic Series 13 | Body Drilling ASME B16.47 Series B

VALVE SIZE		Fastener Size	Stud Bolts & Hex Nuts - L1				Stud Bolts - L2				Hex Head Bolts - L3		
In	mm		In	mm	Qty Studs	Qty Nuts	In	mm	Qty	Qty Nuts	In	mm	Qty Bolts
30	750	3/4" - 8 UNC	6	152	78	156	4.5	254	10	10	3.5	89	10
32	800	3/4" - 8 UNC	6	152	80	160	4.5	406	16	16	3.5	89	16
36	900	7/8" - 8 UNC	7	178	72	144	5	406	16	16	4	102	16
40	1000	1" - 8 UNC	7.25	184	68	136	5.25	508	20	20	4	102	20
42	1050	1" - 8 UNC	8	203	86	172	5.5	254	10	10	4.25	108	10
48	1200	1" - 8 UNC	7.5	191	86	172	5.25	254	10	10	4.25	108	10

NOTES:

- Calculations include 2 washers (.2") for thru stud bolts and 1 washer (.1") for hex bolt and stud bolts/nut.
- Any combination of the above fastener types is applicable.
- All nuts are in accordance with ASME B18.2.2 Table 9 Heavy Hex nuts.
- All Studs are in accordance with ASME B18.2.1.
- All Stud and bolt lengths rounded to next 1/4".
- Standard gaskets (0.125"), one per side, have been included in the bolting calculations.
- Please Consult Factory for fields marked "CF".
- All fields with "N/A" indicate where the bolting requirements are not applicable.

CLASS 150 | GATE - Face to Face API 609, ISO 5752 Basic Series 13 | Body Drilling ASME B16.5

VALVE SIZE		Fastener Size	Stud Bolts & Hex Nuts - L1				Stud Bolts - L2				OR	Hex Head Bolts - L3		
In	mm		In	mm	Qty Studs	Qty Nuts	In	mm	Qty	Qty Nuts		In	mm	Qty Bolts
3	80	5/8" - 11 UNC	4	102	8	16	N/A	N/A	N/A	N/A	N/A	N/A	N/A	
4	100	5/8" - 11 UNC	4	102	12	24	2.75	70	4	4	2.25	57	4	
6	150	3/4" - 10 UNC	4.25	108	12	24	3	76	4	4	2.25	57	4	
8	200	3/4" - 10 UNC	4.5	114	16	32	N/A	N/A	N/A	N/A	N/A	N/A	N/A	
10	250	7/8" - 9 UNC	5	127	24	48	N/A	N/A	N/A	N/A	N/A	N/A	N/A	
12	300	7/8" - 9 UNC	5	127	24	48	N/A	N/A	N/A	N/A	N/A	N/A	N/A	
14	350	1" - 8 UNC	5.5	140	24	48	N/A	N/A	N/A	N/A	N/A	N/A	N/A	
16	400	1" - 8 UNC	5.75	146	32	64	N/A	N/A	N/A	N/A	N/A	N/A	N/A	
18	450	1 1/8" - 8 UN	6.25	159	32	64	N/A	N/A	N/A	N/A	N/A	N/A	N/A	
20	500	1 1/8" - 8 UN	6.5	165	40	80	N/A	N/A	N/A	N/A	N/A	N/A	N/A	
24	600	1 1/4" - 8 UN	7	178	40	80	N/A	N/A	N/A	N/A	N/A	N/A	N/A	

CLASS 150 | GATE - Face to Face API 609, ISO 5752 Basic Series 13 | Body Drilling ASME B16.47 Series A

VALVE SIZE		Fastener Size	Stud Bolts & Hex Nuts - L1				Stud Bolts - L2				OR	Hex Head Bolts - L3		
In	mm		In	mm	Qty Studs	Qty Nuts	In	mm	Qty	Qty Nuts		In	mm	Qty Bolts
30	750	1 1/4" - 8 UN	9.25	235	48	96	6	152	8	8	4.75	121	8	

NOTES:

- Calculations include 2 washers (.2") for thru stud bolts and 1 washer (.1") for hex bolt and stud bolts/nut.
- Any combination of the above fastener types is applicable.
- All nuts are in accordance with ASME B18.2.2 Table 9 Heavy Hex nuts.
- All Studs are in accordance with ASME B18.2.1.
- All Stud and bolt lengths rounded to next 1/4".
- Standard gaskets (0.125"), one per side, have been included in the bolting calculations.
- Please Consult Factory for fields marked "CF".
- All fields with "N/A" indicate where the bolting requirements are not applicable.

CLASS 300 | WAFER - Face to Face API 609, ISO 5752 Basic Series 13 | Body Drilling ASME B16.5

VALVE SIZE		Fastener Size	Stud Bolts & Hex Nuts - L1				Stud Bolts - L2				Hex Head Bolts - L3		
In	mm		In	mm	Qty Studs	Qty Nuts	In	mm	Qty	Qty Nuts	In	mm	Qty Bolts
3	80	3/4" - 10 UNC	6.5	165	8	16	N/A	N/A	N/A	N/A	N/A	N/A	N/A
4	100	3/4" - 10 UNC	7	178	8	16	N/A	N/A	N/A	N/A	N/A	N/A	N/A
6	150	3/4" - 10 UNC	7.5	191	12	24	N/A	N/A	N/A	N/A	N/A	N/A	N/A
8	200	7/8" - 9 UNC	8.75	222	12	24	N/A	N/A	N/A	N/A	N/A	N/A	N/A
10	250	1" - 8 UNC	10	254	12	24	4.5	114	8	8	3.5	89	8
12	300	1 1/8" - 8 UN	11	279	12	24	4.75	121	8	8	3.25	83	8
14	350	1 1/8" - 8 UN	12	305	16	32	4.5	114	8	8	3.25	83	8
16	400	1 1/4" - 8 UN	13.5	343	16	32	5.25	133	8	8	3.25	83	8
18	450	1 1/4" - 8 UN	14	356	20	40	5.25	133	8	8	3.75	95	8
20	500	1 1/4" - 8 UN	15	381	20	40	5.25	133	8	8	4	102	8
24	600	1 1/2" - 8 UN	17	432	20	40	6.25	159	8	8	4.25	108	8

CLASS 300 | WAFER - Face to Face API 609, ISO 5752 Basic Series 13 | Body Drilling ASME B16.47 Series A

VALVE SIZE		Fastener Size	Stud Bolts & Hex Nuts - L1				Stud Bolts - L2				Hex Head Bolts - L3		
In	mm		In	mm	Qty Studs	Qty Nuts	In	mm	Qty	Qty Nuts	In	mm	Qty Bolts
30	750	1 3/4" - 8 UN	20.75	527	24	48	7.25	184	8	8	5.5	140	8
32	800	1 7/8" - 8 UN	CF	CF	CF	CF	CF	CF	CF	CF	CF	CF	CF
36	900	2" - 8 UN	23.5	597	28	56	7.75	197	8	8	6	152	8
40	1000	1 5/8" - 8 UN	CF	CF	CF	CF	CF	CF	CF	CF	CF	CF	CF
42	1050	1 5/8" - 8 UN	27	686	28	56	8.75	222	8	8	6.75	171	8
48	1200	1 7/8" - 8 UN	30.25	768	28	56	10	254	8	8	7.75	197	8

CLASS 300 | WAFER - Face to Face API 609, ISO 5752 Basic Series 13 | Body Drilling ASME B16.47 Series B

VALVE SIZE		Fastener Size	Stud Bolts & Hex Nuts - L1				Stud Bolts - L2				Hex Head Bolts - L3		
In	mm		In	mm	Qty Studs	Qty Nuts	In	mm	Qty	Nuts & Washers	In	mm	Qty Bolts
30	750	1 3/8" - 8 UN	CF	CF	CF	CF	CF	CF	CF	CF	CF	CF	CF
32	800	1 1/2" - 8 UN	CF	CF	CF	CF	CF	CF	CF	CF	CF	CF	CF
36	900	1 5/8" - 8 UN	CF	CF	CF	CF	CF	CF	CF	CF	CF	CF	CF
40	1000	1 5/8" - 8 UN	CF	CF	CF	CF	CF	CF	CF	CF	CF	CF	CF
42	1050	1 3/4" - 8 UN	CF	CF	CF	CF	CF	CF	CF	CF	CF	CF	CF
48	1200	1 7/8" - 8 UN	CF	CF	CF	CF	CF	CF	CF	CF	CF	CF	CF

NOTES:

- Calculations include 2 washers (.2") for thru stud bolts and 1 washer (.1") for hex bolt and stud bolts/nut.
- Any combination of the above fastener types is applicable.
- All nuts are in accordance with ASME B18.2.2 Table 9 Heavy Hex nuts.
- All Studs are in accordance with ASME B18.2.1.
- All Stud and bolt lengths rounded to next 1/4".
- Standard gaskets (0.125"), one per side, have been included in the bolting calculations.
- Please Consult Factory for fields marked "CF".
- All fields with "N/A" indicate where the bolting requirements are not applicable.

CLASS 300 | LUG - Face to Face API 609, ISO 5752 Basic Series 13 | Body Drilling ASME B16.5

VALVE SIZE		Fastener Size	Stud Bolts & Hex Nuts - L1				Stud Bolts - L2				Hex Head Bolts - L3		
In	mm		In	mm	Qty Studs	Qty Nuts	In	mm	Qty	Qty Nuts	In	mm	Qty Bolts
3	80	3/4" - 10 UNC	3.5	89	16	16	N/A	N/A	N/A	N/A	N/A	N/A	N/A
4	100	3/4" - 10 UNC	3.5	89	16	16	N/A	N/A	N/A	N/A	N/A	N/A	N/A
6	150	3/4" - 10 UNC	4	102	24	24	N/A	N/A	N/A	N/A	N/A	N/A	N/A
8	200	7/8" - 9 UNC	4.5	114	24	24	N/A	N/A	N/A	N/A	N/A	N/A	N/A
10	250	1" - 8 UNC	5	127	32	32	4.5	114	8	8	3	76	8
12	300	1 1/8" - 8 UN	5.5	140	24	24	4.5	114	8	8	3.25	83	8
14	350	1 1/8" - 8 UN	5.5	140	32	32	5	127	8	8	3.75	95	8
16	400	1 1/4" - 8 UN	6	152	32	32	5	127	8	8	3.75	95	8
18	450	1 1/4" - 8 UN	6.25	159	40	40	5.25	133	8	8	4	102	8
20	500	1 1/4" - 8 UN	6.25	159	40	40	6	152	8	8	4.5	114	8
24	600	1 1/2" - 8 UN	7.25	184	40	40							

CLASS 300 | LUG - Face to Face API 609, ISO 5752 Basic Series 13 | Body Drilling ASME B16.47 Series A

VALVE SIZE		Fastener Size	Stud Bolts & Hex Nuts - L1				Stud Bolts - L2				Hex Head Bolts - L3		
In	mm		In	mm	Qty Studs	Qty Nuts	In	mm	Qty	Qty Nuts	In	mm	Qty Bolts
30	750	1 3/4" - 8 UN	8.75	222	48	48	7.25	184	8	8	5.5	140	8
32	800	1 7/8" - 8 UN	CF	CF	CF	CF	CF	CF	CF	CF	CF	CF	CF
36	900	2" - 8 UN	9.75	248	56	56	7.75	197	8	8	6	152	8
40	1000	1 5/8" - 8 UN	CF	CF	CF	CF	CF	CF	CF	CF	CF	CF	CF
42	1050	1 5/8" - 8 UN	9.5	241	56	56	8.75	222	8	8	6.75	171	8
48	1200	1 7/8" - 8 UN	9.75	248	56	56	9.75	248	8	8	7.75	197	8

CLASS 300 | LUG - Face to Face API 609, ISO 5752 Basic Series 13 | Body Drilling ASME B16.47 Series B

VALVE SIZE		Fastener Size	Stud Bolts & Hex Nuts - L1				Stud Bolts - L2				Hex Head Bolts - L3		
In	mm		In	mm	Qty Studs	Qty Nuts	In	mm	Qty	Qty Nuts	In	mm	Qty Bolts
30	750	1 3/8" - 8 UN	9	229	64	64	7.25	184	8	8	5.5	140	8
32	800	1 1/2" - 8 UN	CF	CF	CF	CF	CF	CF	CF	CF	CF	CF	CF
36	900	1 5/8" - 8 UN	9.5	241	56	56	7.75	197	8	8	5.75	146	8
40	1000	1 5/8" - 8 UN	CF	CF	CF	CF	CF	CF	CF	CF	CF	CF	CF
42	1050	1 3/4" - 8 UN	9.75	248	64	64	8.25	210	8	8	6.5	165	8
48	1200	1 7/8" - 8 UN	10.5	267	72	72	9.75	248	8	8	7.75	197	8

NOTES:

- Calculations include 2 washers (.2") for thru stud bolts and 1 washer (.1") for hex bolt and stud bolts/nut.
- Any combination of the above fastener types is applicable.
- All nuts are in accordance with ASME B18.2.2 Table 9 Heavy Hex nuts.
- All Studs are in accordance with ASME B18.2.1.
- All Stud and bolt lengths rounded to next 1/4".
- Standard gaskets (0.125"), one per side, have been included in the bolting calculations.
- Please Consult Factory for fields marked "CF".
- All fields with "N/A" indicate where the bolting requirements are not applicable.

CLASS 300 | DOUBLE FLANGE - Face to Face API 609, ISO 5752 Basic Series 13 | Body Drilling ASME B16.5

VALVE SIZE		Fastener Size	Stud Bolts & Hex Nuts - L1				Stud Bolts - L2				Hex Head Bolts - L3		
In	mm		In	mm	Qty Studs	Qty Nuts	In	mm	Qty	Qty Nuts	In	mm	Qty Bolts
3	80	3/4" - 10 UNC	4.5	114	12	24	3.25	83	4	4	2.5	64	4
4	100	3/4" - 10 UNC	4.75	121	12	24	3.25	83	4	4	2.5	64	4
6	150	3/4" - 10 UNC	5	127	20	40	3.75	95	4	4	2.75	70	4
8	200	7/8" - 9 UNC	5.75	146	20	40	4	102	4	4	3.25	83	4
10	250	1" - 8 UNC	6.5	165	24	48	4.25	108	8	8	3.25	83	8
12	300	1 1/8" - 8 UN	7	178	24	48	4.5	114	8	8	3.5	89	8
14	350	1 1/8" - 8 UN	7.25	184	32	64	4.75	121	8	8	3.5	89	8
16	400	1 1/4" - 8 UN	7.75	197	32	64	5.25	133	8	8	3.75	95	8
18	450	1 1/4" - 8 UN	8	203	40	80	5.25	133	8	8	4	102	8
20	500	1 1/4" - 8 UN	8.25	210	40	80	5.5	140	8	8	4	102	8
24	600	1 1/2" - 8 UN	9.25	235	40	80	6	152	8	8	4.5	114	8

CLASS 300 | DOUBLE FLANGE - Face to Face API 609, ISO 5752 Basic Series 13 | Body Drilling ASME B16.47 Series A

VALVE SIZE		Fastener Size	Stud Bolts & Hex Nuts - L1				Stud Bolts - L2				Hex Head Bolts - L3		
In	mm		In	mm	Qty Studs	Qty Nuts	In	mm	Qty	Qty Nuts	In	mm	Qty Bolts
30	750	1 3/4" - 8 UN	12.5	318	40	80	8.5	216	16	16	6	152	16
32	800	1 7/8" - 8 UN	CF	CF	CF	CF	CF	CF	CF	CF	CF	CF	CF
36	900	2" - 8 UN	13.25	337	48	96	8	203	16	16	6	152	16
40	1000	1 5/8" - 8 UN	CF	CF	CF	CF	CF	CF	CF	CF	CF	CF	CF
42	1050	1 5/8" - 8 UN	13.5	343	52	104	8.5	216	12	12	7	178	12
48	1200	1 7/8" - 8 UN	15.25	387	48	96	10.5	267	16	16	8	203	16

CLASS 300 | DOUBLE FLANGE - Face to Face API 609, ISO 5752 Basic Series 13 | Body Drilling ASME B16.47 Series B

VALVE SIZE		Fastener Size	Stud Bolts & Hex Nuts - L1				Stud Bolts - L2				Hex Head Bolts - L3		
In	mm		In	mm	Qty Studs	Qty Nuts	In	mm	Qty	Qty Nuts	In	mm	Qty Bolts
30	750	1 3/8" - 8 UN	11.25	286	56	112	7	178	16	16	5.5	140	16
32	800	1 1/2" - 8 UN	CF	CF	CF	CF	CF	CF	CF	CF	CF	CF	CF
36	900	1 5/8" - 8 UN	12.25	311	56	112	8	203	8	8	6.25	159	8
40	1000	1 5/8" - 8 UN	CF	CF	CF	CF	CF	CF	CF	CF	CF	CF	CF
42	1050	1 3/4" - 8 UN	13.75	349	56	112	8.5	216	16	16	6.75	171	16
48	1200	1 7/8" - 8 UN	14.75	375	60	120	9.75	248	20	20	7.75	197	20

NOTES:

- Calculations include 2 washers (.2") for thru stud bolts and 1 washer (.1") for hex bolt and stud bolts/nut.
- Any combination of the above fastener types is applicable.
- All nuts are in accordance with ASME B18.2.2 Table 9 Heavy Hex nuts.
- All Studs are in accordance with ASME B18.2.1.
- All Stud and bolt lengths rounded to next 1/4".
- Standard gaskets (0.125"), one per side, have been included in the bolting calculations.
- Please Consult Factory for fields marked "CF".
- All fields with "N/A" indicate where the bolting requirements are not applicable.

CLASS 300 | GATE - Face to Face API 609, ISO 5752 Basic Series 13 | Body Drilling ASME B16.5

VALVE SIZE		Fastener Size	Stud Bolts & Hex Nuts - L1				Stud Bolts - L2				Hex Head Bolts - L3		
In	mm		In	mm	Qty Studs	Qty Nuts	In	mm	Qty	Qty Nuts	In	mm	Qty Bolts
3	80	3/4" - 10 UNC	4.5	114	12	24	3.5	89	4	4	2.5	64	4
4	100	3/4" - 10 UNC	4.75	121	12	24	3.5	89	4	4	2.5	64	4
6	150	3/4" - 10 UNC	5.25	133	20	40	3.75	95	4	4	2.75	70	4
8	200	7/8" - 9 UNC	5.75	146	20	40	4	102	4	4	3.25	83	4
10	250	1" - 8 UNC	6.5	165	32	64	N/A	N/A	N/A	N/A	N/A	N/A	N/A
12	300	1 1/8" - 8 UN	7	178	32	64	N/A	N/A	N/A	N/A	N/A	N/A	N/A
14	350	1 1/8" - 8 UN	7.25	184	36	72	5	127	4	4	4	102	4
16	400	1 1/4" - 8 UN	7.75	197	36	72	5.75	146	4	4	4.25	108	4
18	450	1 1/4" - 8 UN	8	203	44	88	6	152	4	4	4.5	114	4
20	500	1 1/4" - 8 UN	8.25	210	44	88	6	152	4	4	4.5	114	4
24	600	1 1/2" - 8 UN	9.25	235	48	96	N/A	N/A	N/A	N/A	N/A	N/A	N/A

CLASS 600 | DOUBLE FLANGE - Face to Face API 609, ISO 5752 Basic Series 13 | Body Drilling ASME B16.5

VALVE SIZE		Fastener Size	Stud Bolts & Hex Nuts - L1				Stud Bolts - L2				Hex Head Bolts - L3		
In	mm		In	mm	Qty Studs	Qty Nuts	In	mm	Qty	Qty Nuts	In	mm	Qty Bolts
6	150	1" - 8 UNC	7.25	184	16	32	5.5	140	8	8	4	102	8
8	200	1 1/8" - 8 UN	8.25	210	16	32	6	152	8	8	4.5	114	8
10	250	1 1/4" - 8 UN	9	229	24	48	6.75	171	8	8	5	127	8
12	300	1 1/4" - 8 UN	9.25	235	32	64	7	178	8	8	5.25	133	8
14	350	1 3/8" - 8 UN	10	254	32	64	7.5	191	8	8	5.5	140	8
16	400	1 1/2" - 8 UN	10.75	273	32	64	8	203	8	8	6	152	8
18	450	1 5/8" - 8 UN	11.5	292	24	48	8.5	216	16	16	6.5	165	16
20	500	1 5/8" - 8 UN	12	305	32	64	8.75	222	16	16	6.75	171	16
24	600	1 7/8" - 8 UN	13.5	343	32	64	10	254	16	16	7.5	191	16

NOTES:

- Calculations include 2 washers (.2") for thru stud bolts and 1 washer (.1") for hex bolt and stud bolts/nut.
- Any combination of the above fastener types is applicable.
- All nuts are in accordance with ASME B18.2.2 Table 9 Heavy Hex nuts.
- All Studs are in accordance with ASME B18.2.1.
- All Stud and bolt lengths rounded to next 1/4".
- Standard gaskets (0.125"), one per side, have been included in the bolting calculations.
- Please Consult Factory for fields marked "CF".
- All fields with "N/A" indicate where the bolting requirements are not applicable.

SINCE 1986, BRAY HAS PROVIDED FLOW CONTROL SOLUTIONS FOR A VARIETY OF INDUSTRIES AROUND THE WORLD.

VISIT **BRAY.COM** TO LEARN MORE ABOUT BRAY PRODUCTS AND LOCATIONS NEAR YOU.

HEADQUARTERS

Bray International, Inc.

13333 Westland East Blvd.

Houston, Texas 77041

Tel: +1.281.894.5454

All statements, technical information, and recommendations in this bulletin are for general use only. Consult Bray representatives or factory for the specific requirements and material selection for your intended application. The right to change or modify product design or product without prior notice is reserved. Patents issued and applied for worldwide. Bray® is a registered trademark of Bray International, Inc.

© 2022 BRAY INTERNATIONAL. ALL RIGHTS RESERVED. BRAY.COM

EN_BR_TSM_BF_Tri Lok_20220810



THE HIGH PERFORMANCE COMPANY

BRAY.COM