

MOUNTING AND OPERATING INSTRUCTIONS

SAMSON

EB 2111/2121/2123 EN

Translation of original instructions

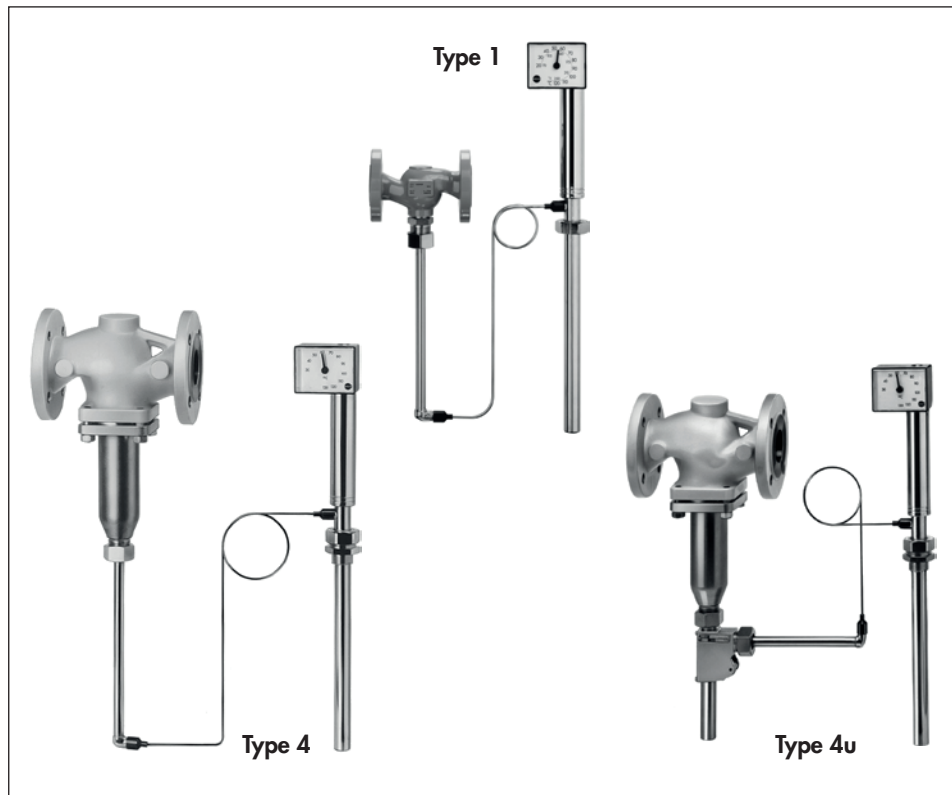

Type 1, Type 4 and Type 4u Temperature Regulators Self-operated Regulators

Edition November 2022



Note on these mounting and operating instructions

These mounting and operating instructions assist you in mounting and operating the device safely. The instructions are binding for handling SAMSON devices. The images shown in these instructions are for illustration purposes only. The actual product may vary.

- For the safe and proper use of these instructions, read them carefully and keep them for later reference.
- If you have any questions about these instructions, contact SAMSON's After-sales Service (aftersaleservice@samsongroup.com).



The mounting and operating instructions for the devices are included in the scope of delivery. The latest documentation is available on our website at www.samsongroup.com > **Service & Support** > **Downloads** > **Documentation**.

Definition of signal words

DANGER

Hazardous situations which, if not avoided, will result in death or serious injury

WARNING

Hazardous situations which, if not avoided, could result in death or serious injury

NOTICE

Property damage message or malfunction

Note

Additional information

Tip

Recommended action

| | | |
|----------|---|------------|
| 1 | Safety instructions and measures | 1-1 |
| 1.1 | Notes on possible severe personal injury | 1-5 |
| 1.2 | Notes on possible personal injury | 1-5 |
| 1.3 | Notes on possible property damage | 1-7 |
| 2 | Markings on the device | 2-1 |
| 2.1 | Valve nameplate | 2-1 |
| 2.2 | Nameplate of the control thermostat | 2-2 |
| 2.3 | Location of the nameplates | 2-2 |
| 2.4 | Material identification number | 2-2 |
| 2.4.1 | Type 2111 and Type 2422 Valve | 2-2 |
| 2.4.2 | Types 2231 to 2234 Control Thermostat | 2-2 |
| 3 | Design and principle of operation | 3-1 |
| 3.1 | Accessories | 3-3 |
| 3.2 | Additional fittings..... | 3-5 |
| 3.3 | Technical data | 3-6 |
| 4 | Shipment and on-site transport | 4-1 |
| 4.1 | Accepting the delivered goods | 4-1 |
| 4.1 | Removing the packaging from the regulator | 4-1 |
| 4.2 | Transporting and lifting the regulator | 4-2 |
| 4.2.1 | Transporting the regulator..... | 4-2 |
| 4.2.2 | Lifting the regulator | 4-3 |
| 4.3 | Storing the regulator | 4-4 |
| 5 | Installation | 5-1 |
| 5.1 | Installation conditions | 5-1 |
| 5.2 | Preparation for installation..... | 5-4 |
| 5.3 | Installation..... | 5-4 |
| 5.4 | Installing the regulator | 5-6 |
| 5.4.1 | Installing the valve..... | 5-6 |
| 5.4.2 | Installing the control thermostat | 5-7 |
| 5.4.3 | Installing the reversing device..... | 5-7 |
| 5.5 | Cleaning the pipeline | 5-8 |
| 5.6 | Testing the regulator | 5-8 |
| 5.6.1 | Leak test | 5-9 |
| 5.6.2 | Pressure test..... | 5-10 |
| 5.6.3 | Filling the plant | 5-11 |
| 5.7 | Insulation | 5-11 |
| 5.8 | Mounting accessories | 5-11 |

Contents

| | | |
|-----------|--|-------------|
| 6 | Start-up | 6-1 |
| 6.1 | Start-up and putting the device back into operation | 6-2 |
| 6.2 | Starting up the plant when vapors and liquids are controlled | 6-2 |
| 6.3 | Starting up the plant when vapors are controlled | 6-2 |
| 7 | Operation | 7-1 |
| 7.1 | Adjusting the temperature set point | 7-1 |
| 7.2 | Correcting the set point dial | 7-2 |
| 7.3 | Excess temperature safeguard of the thermostat | 7-2 |
| 8 | Malfunctions | 8-1 |
| 8.1 | Troubleshooting | 8-1 |
| 8.2 | Emergency action | 8-5 |
| 9 | Servicing..... | 9-1 |
| 9.1 | Preparing the valve for service work | 9-4 |
| 9.2 | Installing the regulator after service work | 9-4 |
| 9.3 | Service work..... | 9-5 |
| 9.4 | Replacing the control thermostat..... | 9-5 |
| 9.5 | Replacing the seat and plug..... | 9-6 |
| 9.6 | Ordering spare parts and operating supplies | 9-6 |
| 10 | Decommissioning | 10-1 |
| 11 | Removal | 11-1 |
| 11.1 | Removing the control thermostat..... | 11-1 |
| 11.2 | Removing the regulator from the pipeline..... | 11-1 |
| 12 | Repairs | 12-1 |
| 12.1 | Returning devices to SAMSON | 12-1 |
| 13 | Disposal..... | 13-1 |
| 14 | Certificates..... | 14-1 |
| 15 | Annex..... | 15-1 |
| 15.1 | Tightening torques..... | 15-1 |
| 15.2 | Lubricant..... | 15-1 |
| 15.3 | Tools | 15-1 |
| 15.4 | Accessories | 15-1 |
| 15.5 | Spare parts | 15-2 |
| 15.5.1 | Valve | 15-2 |
| 15.5.2 | Control thermostat..... | 15-4 |
| 15.6 | After-sales service | 15-4 |

1 Safety instructions and measures

Intended use

The SAMSON Type 1, Type 4 and Type 4u Regulators are temperature regulators. They consist of a Type 2111 or Type 2422 Valve and a Type 2231, Type 2232 or Type 2234 Control Thermostat. These regulator components are delivered separately.

The self-operated regulators are used to control the temperature in plants. Liquids, gases and vapors in district heating system, extended heating systems or industrial plants can be controlled by the regulators.

The regulators are designed to operate under exactly defined conditions (e.g. operating pressure, process medium, temperature). Therefore, operators must ensure that the regulators are only used in operating conditions that meet the specifications used for sizing the devices at the ordering stage. In case operators intend to use the regulators in applications or conditions other than those specified, contact SAMSON.

SAMSON does not assume any liability for damage resulting from the failure to use the device for its intended purpose or for damage caused by external forces or any other external factors.

➔ Refer to the technical data and nameplate for limits and fields of application as well as possible uses.

Reasonably foreseeable misuse

The regulators are not suitable for the following applications:

- Use outside the limits defined during sizing and by the technical data
- Use outside the limits defined by the additional fittings mounted on the regulator

Furthermore, the following activities do not comply with the intended use:

- Use of non-original spare parts
- Performing service and repair work not described

Qualifications of operating personnel

The regulator must be mounted, started up, serviced and repaired by fully trained and qualified personnel only; the accepted industry codes and practices must be observed. According to these mounting and operating instructions, trained personnel refers to individuals who are able to judge the work they are assigned to and recognize possible hazards due to their specialized training, their knowledge and experience as well as their knowledge of the applicable standards.

Safety instructions and measures

Personal protective equipment

We recommend checking the hazards posed by the process medium being used (e.g.

▶ GESTIS (CLP) hazardous substances database). Depending on the process medium and/or the activity, the protective equipment required includes:

- Protective clothing, safety gloves and eye protection in applications with hot, cold and/or corrosive media
 - Wear hearing protection when working near the valve
 - Hard hat
 - Safety harness when working at height
 - Safety footwear, ESD (electrostatic discharge) footwear, if necessary
- ➔ Check with the plant operator for details on further protective equipment.

Revisions and other modifications

Revisions, conversions or other modifications of the product are not authorized by SAMSON. They are performed at the user's own risk and may lead to safety hazards, for example. Furthermore, the product may no longer meet the requirements for its intended use.

Warning against residual hazards

To avoid personal injury or property damage, plant operators and operating personnel must prevent hazards that could be caused in the regulator by the process medium, the operating pressure or by moving parts by taking appropriate precautions. Plant operators and operating personnel must observe all hazard statements, warning and caution notes in these mounting and operating instructions.

Hazards resulting from the special working conditions at the installation site of the regulator must be identified in a risk assessment and prevented through the corresponding safety instructions drawn up by the operator.

We also recommend checking the hazards posed by the process medium being used (e.g.

▶ GESTIS (CLP) hazardous substances database).

- ➔ Observe safety measures for handling the device as well as fire prevention and explosion protection measures.

These mounting and operating instructions deals with the standard version of the device. Components of the device that differ to those used for the standard version described in this document can be exchanged with other certain SAMSON components. The residual hazards of these components are described in the associated mounting and operating instructions (see documents listed under 'Referenced documentation').

Safety features

The Type 1, Type 4 and Type 4u Regulators do not have any special safety features. When relieved of pressure, the Type 1 and Type 4 Regulators are opened by the force of the set point springs. When relieved of pressure, the Type 4u Regulator is closed by the force of the set point springs in the reversing device.

Responsibilities of the operator

Operators are responsible for proper use and compliance with the safety regulations. Operators are obliged to provide these mounting and operating instructions as well as the referenced documents to the operating personnel and to instruct them in proper operation. Furthermore, operators must ensure that operating personnel or third parties are not exposed to any danger.

Operators are additionally responsible for ensuring that the limits for the product defined in the technical data are observed. This also applies to the start-up and shutdown procedures. Start-up and shutdown procedures fall within the scope of the operator's duties and, as such, are not part of these mounting and operating instructions. SAMSON is unable to make any statements about these procedures since the operative details (e.g. differential pressures and temperatures) vary in each individual case and are only known to the operator.

Responsibilities of operating personnel

Operating personnel must read and understand these mounting and operating instructions as well as the referenced documents and observe the specified hazard statements, warnings and caution notes. Furthermore, operating personnel must be familiar with the applicable health, safety and accident prevention regulations and comply with them.

Referenced standards, directives and regulations

The regulators comply with the requirements of the European Pressure Equipment Directive 2014/68/EU. Regulators with a CE marking have an EU declaration of conformity, which includes information about the applied conformity assessment procedure. This EU declaration of conformity is included in the 'Certificates' section.

According to the ignition hazard assessment performed in accordance with Clause 5.2 of ISO 80079-36, the non-electrical regulators do not have their own potential ignition source even in the rare incident of an operating fault. As a result, they do not fall within the scope of Directive 2014/34/EU.

- ➔ For connection to the equipotential bonding system, observe the requirements specified in Clause 6.4 of EN 60079-14 (VDE 0165-1).

Referenced documentation

The following documents apply in addition to these mounting and operating instructions:

- Mounting and operating instructions for
 - e.g. **Type 2231 and Type 2232 Control Thermostats (bulb sensors)
Type 2234 Air Sensor** ▶ EB 2231

 - e.g. **Type 2213 Safety Temperature Monitor (STM)** ▶ EB 2043

 - e.g. **Safety temperature limiters (STL) with Type 2212 Safety
Thermostat** ▶ EB 2046

 - e.g. **Type 2 N or NI Strainer** ▶ EB 1015

- Data sheets for
 - e.g. **Double adapter Do2, Do2S · Manual adjuster Ma, MaS
for temperature, differential pressure and flow regulators** ▶ T 2036

 - e.g. **Typetested safety devices Type 1/..., 4/..., 9/...** ▶ T 2040

 - e.g. **Type 2213 Safety Temperature Monitor (STM)** ▶ T 2043

 - e.g. **Safety temperature limiters (STL) with Type 2212 Safety
Thermostat** ▶ T 2046

 - e.g. **Type 2 N or NI Strainer** ▶ T 1015

- Mounting and operating instructions as well as data sheets for additional fittings (e.g. shut-off valves, pressure gauges etc.).

1.1 Notes on possible severe personal injury

DANGER

Risk of bursting in pressure equipment.

Regulators and pipelines are pressure equipment. Impermissible pressure or improper opening can lead to regulator components bursting.

- Observe the maximum permissible pressure for regulator and plant.
- If necessary, a suitable overpressure protection must be installed on site in the plant section.
- Before starting any work on the regulator, depressurize all plant sections affected as well as the regulator.
- Drain the process medium from all the plant sections affected as well as the regulator.
- Wear personal protective equipment.

1.2 Notes on possible personal injury

WARNING

Risk of personal injury through incorrect operation, use or installation as a result of information on the regulator being illegible.

Over time, markings, labels and nameplates on the regulator may become covered with dirt or become illegible in some other way. As a result, hazards may go unnoticed and the necessary instructions not followed. There is a risk of personal injury.

- Keep all relevant markings and inscriptions on the device in a constantly legible state.
- Immediately renew damaged, missing or incorrect nameplates or labels.

WARNING

Risk of hearing loss or deafness due to loud noise.

The noise emissions depend on the valve version, plant facilities and process medium.

- Wear hearing protection when working near the valve. Follow the instructions given by the plant operator.

Risk of personal injury due to pressurized components and process medium being discharged.

Incorrect opening of pressure equipment or mounting parts may lead to the process medium escaping to the atmosphere.

- Do not loosen the control thermostat while the valve is pressurized.
- Do not start up the regulator until all parts have been mounted.

Risk of burn injuries due to hot or cold components and pipelines.

Depending on the process medium, regulator components and pipelines may get very hot or cold and cause burn injuries.

- Allow components and pipelines to cool down or warm up to the ambient temperature.
- Wear protective clothing and safety gloves.

Damage to health relating to the REACH regulation.

If a SAMSON device contains a substance which is listed as being a substance of very high concern on the candidate list of the REACH regulation, this circumstance is indicated on the SAMSON delivery note.

- Information on safe use of the part affected ► www.samsongroup.com/en/about-samson/material-compliance/reach-regulation/.

Risk of personal injury due to residual process medium in the regulator.

While working on the regulator, residual process medium can escape and, depending on its properties, may lead to personal injury, e.g. (chemical) burns.

- If possible, drain the process medium from all the plant sections affected and the regulator.
- Wear protective clothing, safety gloves and eye protection.

1.3 Notes on possible property damage

! NOTICE

Risk of regulator damage due to incorrectly attached slings.

- Do not attach load-bearing slings to the control thermostat (see information under 'Lifting the regulator' in the 'Shipment and on-site transport' section).

Risk of regulator damage due to unsuitable medium properties.

The regulator is designed for a process medium with defined properties.

- Only use the process medium specified for sizing the equipment.

Risk of regulator damage due to contamination (e.g. solid particles) in the pipeline.

The plant operator is responsible for cleaning the pipelines in the plant.

- Flush the pipelines before start-up.

Risk of regulator damage due to the use of unsuitable lubricants.

The lubricants to be used depend on the regulator material. Unsuitable lubricants may corrode and damage surfaces.

- Only use lubricants approved by SAMSON.
When in doubt, consult SAMSON.

Risk of leakage and regulator damage due to excessively high or low tightening torques.

Observe the specified torques when tightening regulator components. Excessive tightening torques lead to parts wearing out more quickly. Parts that are too loose may cause leakage.

- Observe the specified tightening torques (see 'Tightening torques' in Annex).

Risk of regulator damage due to the use of unsuitable tools.

Certain tools are required to work on the regulator.

- Only use tools approved by SAMSON.
When in doubt, consult SAMSON.

! NOTICE

Risk of the process medium being contaminated through the use of unsuitable lubricants and/or contaminated tools and components.

- Keep the regulator and the tools used free from solvents and grease.
- Make sure that only suitable lubricants are used.

Risk of excess pressure damaging plant sections due to construction-related seat leakage through the regulator.

- Always install a safety device (e.g. safety excess pressure valve or safety relief valve) in the plant.

Risk of irreparable regulator damage caused by the regulator components being taken apart.

The control thermostat is an inseparable hydraulic unit consisting of a control thermostat, capillary tube and temperature sensor. If these components are dismantled (e.g. removal of the capillary tube), the regulator will be irreparably damaged and will no longer be able to fulfill its control task.

- Do not dismantle the regulator.
- Only perform allowed activities on the regulator.
- Contact SAMSON's After-sales Service before replacing spare parts.

i Note

SAMSON's After-sales Service can support you concerning lubricant, tightening torques and tools approved by SAMSON.

2 Markings on the device

Several nameplates are affixed to the device. The nameplates are used to identify the separate regulator components (see section 2.1).

2.1 Valve nameplate

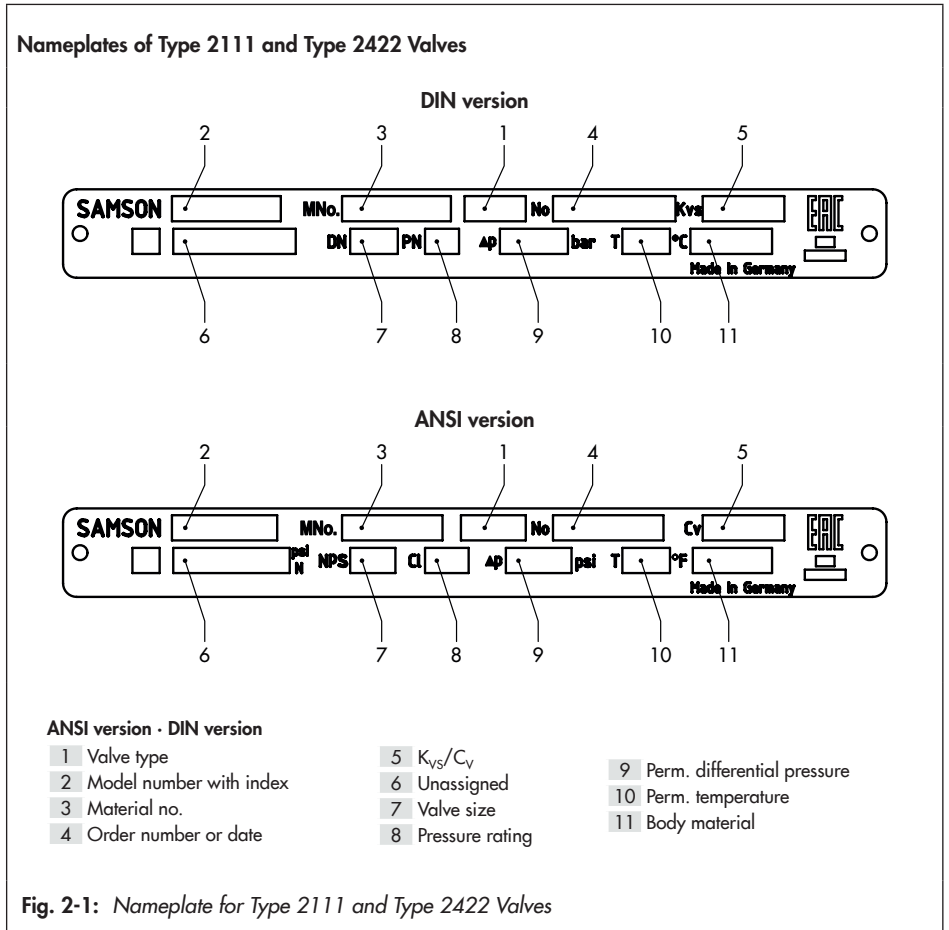

2.2 Nameplate of the control thermostat

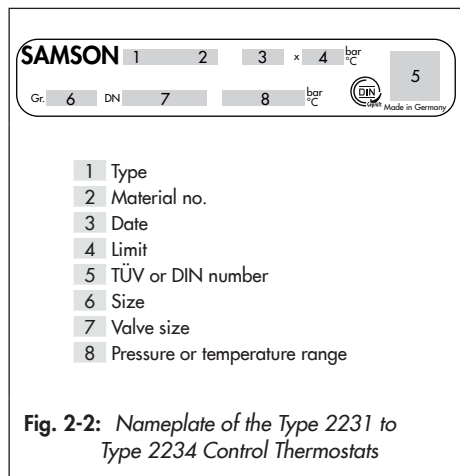

2.4 Material identification number

2.4.1 Type 2111 and Type 2422 Valve

See the nameplate (11 for DIN/ANSI version, body material) for the material used. For more details on the nameplate, see section 2.1.

2.4.2 Types 2231 to 2234 Control Thermostat

Specifying the material number, you can contact us to find out which material is used. This is specified on the nameplate in the 'MNo.' field (2). For more details on the nameplate, see section 2.1.

2.3 Location of the nameplates

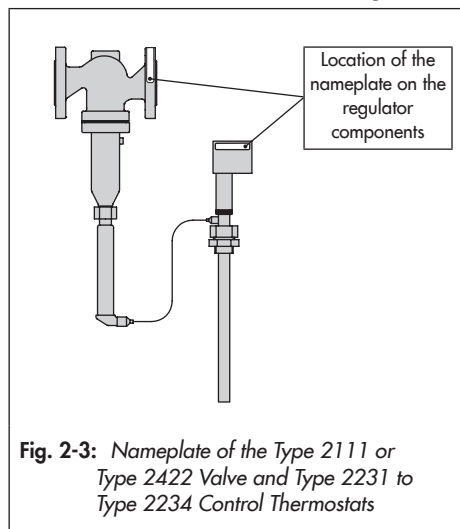

3 Design and principle of operation

→ See Fig. 3-1

Type 1/Type 4: the valve closes as the medium temperature rises and when the temperature rises above the adjusted set point.

Type 4u: the valve opens as the medium temperature rises and when the temperature rises above the adjusted set point.

The temperature regulators consist of the valve (1), thermostat (temperature sensor) (19) and capillary tube (11).

The valve mainly consists of the body with seat (2), plug (3) and plug stem (5). Depending on the application, different thermostats can be attached to the valve.

The thermostat comprises the temperature sensor (19), set point adjuster (12.2), capillary tube (11) and operating element (8).

The temperature regulators operate according to the liquid expansion principle. When, for example the temperature at the temperature sensor (19) increases, the liquid contained in the sensor expands, causing the pin (9) of the operating element to be pushed upward by the bellows (10). During this process, the pin pushes the plug stem (5) together with the plug (3) towards the valve seat as the temperature at the sensor continues to rise until the valve is fully closed.

The **Type 1** Temperature Regulator is equipped with an unbalanced valve. In contrast, **Type 4** has a valve balanced by a metal bellows (4.1).

In this case, the upstream pressure is transferred through the hole in the plug stem to

the outer surface of the bellows and the downstream pressure to the inside of the bellows.

As a result, the forces acting on the plug are balanced out and the valve is fully balanced. Consequently, any pressure changes in the process medium do not affect the position of the valve plug.

The **Type 4u** Temperature Regulator acts in the reverse direction and is used in plants for cooling. Its principle of operation is reverse to that of the standard version, i.e. the valve opens when the temperature at the sensor rises. To achieve this, a reversing device is installed between the valve and the operating element in Type 4u.

The set point can be adjusted at the set point adjuster (12.2) using the key (12.1). By turning the key, a spindle moves the piston (18) up or down. The resulting change in volume in the sensor (19) causes the valve plug to travel according to the adjusted set point within a higher or lower temperature range measured by the sensor.

Version with safety thermostat

When a Type 2212 or Type 2213 Safety Thermostat is attached to the valve or the regulator, this combination functions as a safety temperature limiter (TR/STL) or a safety temperature monitor (TR/STM).

Details in mounting and operating instructions

▶ EB 2046 (STL); ▶ EB 2043 (STM).

Design and principle of operation

Type 1 with Type 2111 Valve

Flanged valve body EN-GJS-400-18-LT,
EN-GJL-250

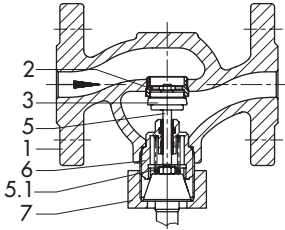

Type 4/Type 4u with Type 2422 Valve

Flanged valve body EN-GJL-250,
EN-GJS-400-18-LT, 1.0619, 1.4408

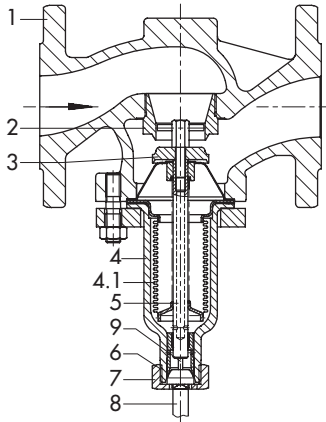

Flanged valve body 1.0619, 1.4408

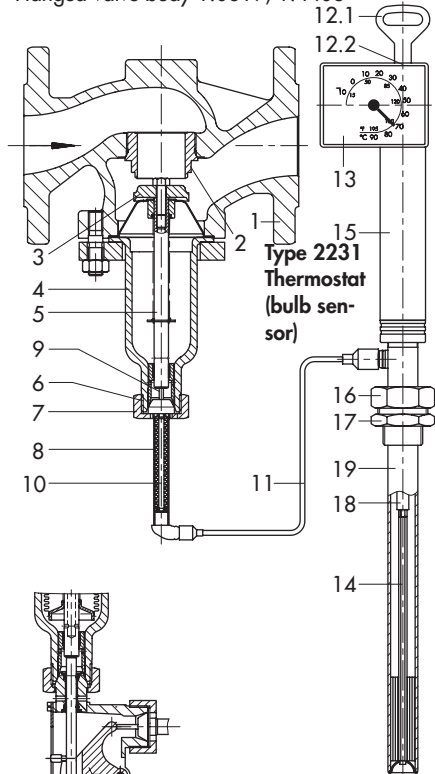

Type 2231
Thermostat
(bulb sensor)

Type 4u with reversing device

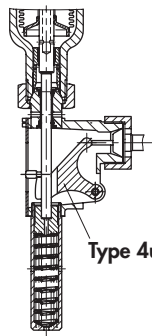

Fig. 3-1: Functional diagram

| | | | | | |
|-----|-------------------|------|---|------|-------------------------------|
| 1 | Valve body | 6 | Threaded connection for operating element | 12.2 | Set point adjuster |
| 2 | Seat | 7 | Coupling nut | 13 | Set point dial |
| 3 | Plug | 8 | Operating element | 14 | Spindle |
| 4 | Bottom section | 9 | Pin of operating element | 15 | Excess temperature protection |
| 4.1 | Balancing bellows | 10 | Operating bellows | 16 | Coupling nut |
| 5 | Plug stem | 11 | Capillary tube | 17 | Double nipple |
| 5.1 | Spring | 12.1 | Set point adjustment key | 18 | Piston |
| | | | | 19 | Thermostat with bulb sensor |

3.1 Accessories

→ See Fig. 3-2

Version with double adapter

The temperature regulator can be equipped with a double adapter to connect an additional control thermostat to control a further control variable.

See Data Sheet ► T 2036.

Version with handwheel

For the manual operation of the valve. The manual adjuster can either be attached directly to the valve or at the double adapter instead of a control thermostat.

See Data Sheet ► T 2036.

Extension piece

An extension piece is installed between valve and thermostat to protect the operating element against high temperatures.

Type 1: DN 15 to 50 for 220 °C and higher; with Type 2212 STL/Type 2213 STM: with valve made of spheroidal graphite iron and cast iron for 150 °C and higher.

Type 4: DN 15 to 100 for 220 °C and higher, DN 125 to 250 for 220 °C and higher already mounted to the valve, up to max. 350 °C.

Separating piece

Mounted between the operating element and valve. It protects the operating element against overall pressures above 16 bar. In stainless steel regulators, it separates the operating element made free of non-ferrous metals from the medium in the valve. In addition, it prevents the medium from escaping on removing the thermostat.

Version A1: the spindle (2) is fitted with O-rings and seals the operating element against the process medium.

Version A2: a metal bellows is used as a sealing element.

i Note

The Type 1, Type 4 and Type 4u Regulators are not safety valves. If necessary, a suitable overpressure protection must be installed on site in the plant section.

Table 3-1: Design of Type 1 and Type 4

| Temperature regulator | Valve | Thermostat |
|-----------------------|---------------------------------|------------------------|
| Type 1 | Type 2111 | Type 2231 to Type 2234 |
| Type 4 | Type 2422 | |
| Type 4u | Type 2422 with reversing device | |

Design and principle of operation

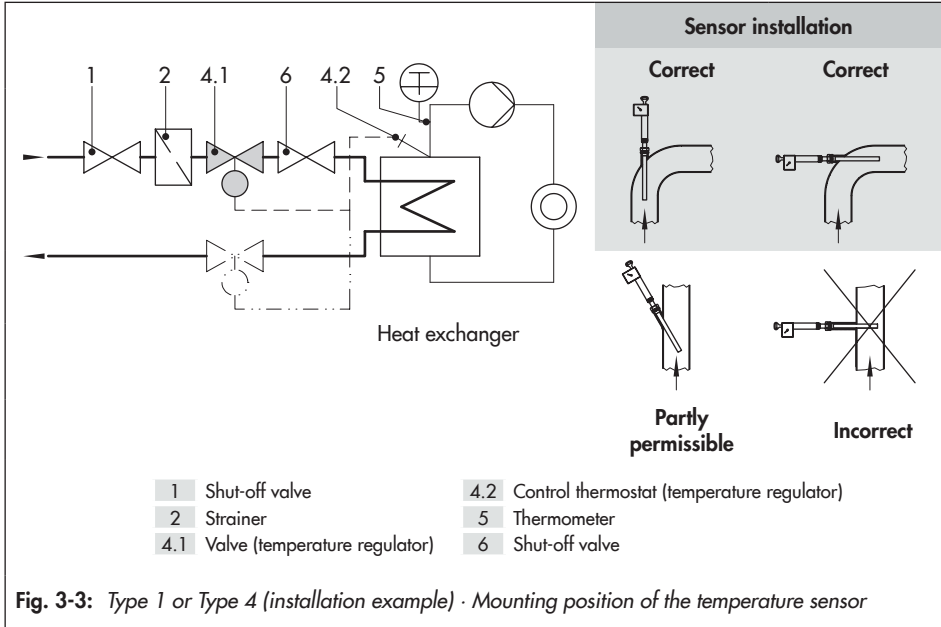
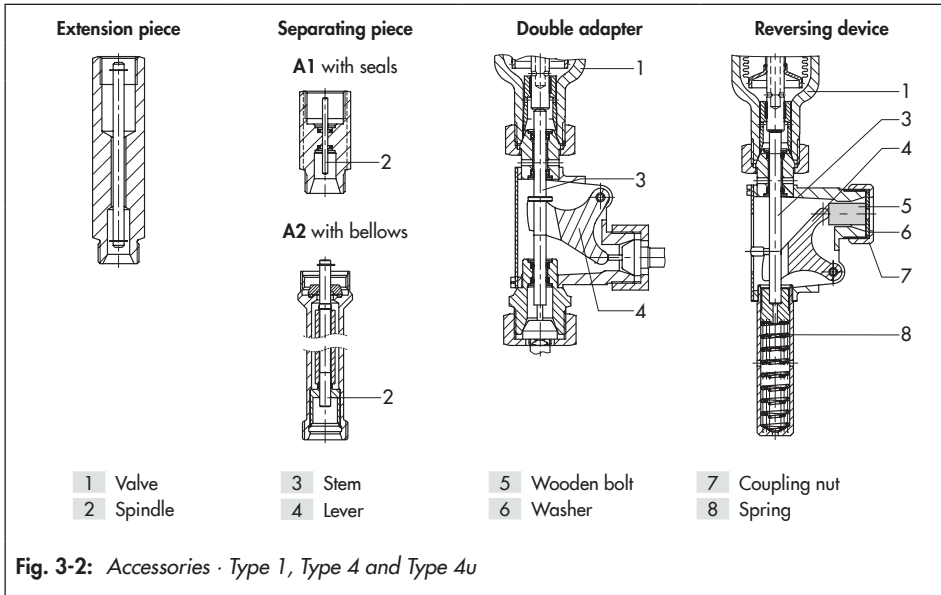

3.2 Additional fittings

→ See Fig. 3-3

Strainers

We recommend installing a SAMSON strainer (2) upstream of the valve. It prevents solid particles in the process medium from damaging the regulator.

- Do not use the strainer to permanently filter the process medium.
- Select a strainer (mesh size) suitable for the process medium.

i Note

Any impurities carried along by the process medium may impair the proper functioning of the regulator. We recommend installing a strainer (e.g. SAMSON Type 2 NI) upstream of the temperature regulator (► EB 1015).

Thermometer

Install a thermometer (3 and 5) at suitable points to monitor the temperatures prevailing in the plant.

Bypass and shut-off valves

We recommend installing a shut-off valve (1 and 6) both upstream of the strainer and downstream of the regulator and installing a bypass line. The bypass ensures that the plant does not need to be shut down for service and repair work on the regulator.

Insulation

Regulators can be insulated to reduce heat energy transfer.

Refer to the instructions in the 'Installation' section.

3.3 Technical data

The valve and actuator nameplates provide information on the valve and actuator versions (see the 'Markings on the device' section).

i Note

More information is available in Data Sheets
▶ T 2111, ▶ T 2121 and ▶ T 2123.

Process medium and scope of application

The temperature regulators are designed to maintain the temperature to the adjusted set point.

- For **liquids, gases and vapors**
- Max. temperature **350 °C/175 °F**
- Set points from **-10 to +250 °C/15 to 480 °F**
- Valve sizes **DN 15 to 150/NPS ½ to 6**
- Pressure ratings **PN 40 to 40/Class 150 to 300**

The Type 1 and Type 4 Regulators are open when relieved of pressure. The valve **closes** when the temperature **rises**.

The Type 4u Regulator is closed when relieved of pressure. The valve **opens** when the temperature **rises**.

Conformity

The Type 1, Type 4 and Type 4u Regulators bear both the CE and EAC marks of conformity.

CE

EAC

Leakage class

The metal-seated regulator has the leakage class I according to IEC 60534-4.

The soft-seated regulator has the leakage class IV according to IEC 60534-4.

Temperature range

Depending on how the regulator is configured, it can be used up to temperatures of 350 °C/660 °F (see Table 3-2). The minimum temperature is limited by the accessories used and the actuator's diaphragm material (▶ T 2121 and ▶ T 2123).

Noise emissions

SAMSON is unable to make general statements about noise emissions. The noise emissions depend on the regulator version, plant facilities, process medium and operating conditions.

Dimensions and weights

Table 3-7 to Table 3-9 provide an overview of the dimensions and weights. The lengths and heights in the dimensional drawings are shown on pages 3-12 and 3-13.

Table 3-2: Technical data · Valves · All pressures in bar (gauge)



| Type 2111 Valve unbalanced Type 2422 Valve · Balanced by a bellows · Balanced by a diaphragm | | | | |
|---|-------------------------|---|--|--|
| Valve size | | DN 15 to 50/ NPS ½ to 2 | DN 65 to 100/ NPS 2½ to 4 | DN 125 to 150/ NPS 5 to 6 |
| Pressure rating | | PN 16, 25, 40 | | |
| Permissible valve temperature | Without balancing | Max. 350 °C · See pressure-temperature diagram in ► T 2010 | - | |
| | Balanced by a bellows | Max. 350 °C · See pressure-temperature diagram in ► T 2010 | | |
| | Balanced by a diaphragm | - | Max. 150 °C · See pressure-temperature diagram in ► T 2010 | - |
| Leakage class according to IEC 60534-4 | Without balancing | ≤0.05 % of K_{VS} coefficient | - | |
| | Balanced by a bellows | Metal seal: ≤0.05 % of K_{VS} coefficient | | Soft seal: ≤0.01 % of K_{VS} coefficient |
| | Balanced by a diaphragm | - | Soft seal: ≤0.01 % of K_{VS} coefficient | - |
| Conformity | |   | | |

Table 3-3: Technical data · Control thermostats · All pressures in bar (gauge)

| Types 2231 to 2234 Control Thermostat | | Size 150 |
|---|-------------------------|--|
| Set point ranges | | -10 to +90 °C, 20 to 120 °C or 50 to 150 °C For Types 2232, 2234 also 100 to 200 °C, 150 to 250 °C |
| Perm. ambient temperature at the set point adjustment | | -40 to +80 °C |
| Perm. temperature at the sensor | | 100 K above the adjusted set point |
| Perm. pressure at sensor | Type 2231 and Type 2232 | Without/with thermowell: PN 40 · With thermowell: PN 40 · PN 100 ¹⁾ Thermowell with flange: PN 40 · PN 100 ¹⁾ |
| | Type 2234 | Without thermowell: PN 40 · With flange on request |
| Capillary tube length | | 5 m (10 or 15 m as special version) |

¹⁾ Thermowell (DVGW version)

Design and principle of operation

Table 3-4: K_{VS} coefficients, x_{FZ} values and max. permissible differential pressures Δp

| Type 2111 Valve - Unbalanced | | | | | | | | | | | | |
|---|----|-----------------------|----------------------|-------------------------------------|-------|---------------------|-------|--------|----|--------|--------|--------|
| Valve size | DN | 15 | 20 | 25 | 32 | 40 | 50 | | | | | |
| K_{VS} coefficient | | 4.0 | 6.3 | 8.0 | 16 | 20 | 32 | | | | | |
| Max. perm. differential pressure Δp | | 25 bar ¹⁾ | 16 bar ¹⁾ | 14 bar | 6 bar | 6 bar ²⁾ | 4 bar | | | | | |
| Reduced K_{VS} coefficient | | 0.1 · 0.4 · 1.0 · 2.5 | | 0.1 · 0.4 · 1.0 · 4.0 ¹⁾ | | 6.3 ¹⁾ | 8.0 | 16 | | | | |
| Max. permissible differential pressure Δp | | 25 bar | | | 16 | 14 | 6 | | | | | |
| Type 2422 Valve - Balanced by a bellows | | | | | | | | | | | | |
| Valve size | DN | 15 | 20 | 25 | 32 | 40 | 50 | 65 | 80 | 100 | 125 | 150 |
| Valve travel | | 10 mm | | | | | | 16 mm | | | 22 mm | |
| K_{VS} coefficient | | 4.0 | 6.3 | 8.0 | 16 | 20 | 32 | 50 | 80 | 125 | 190 | 280 |
| Max. permissible differential pressure Δp | | 25 bar | | | | | | 20 bar | | 16 bar | 12 bar | |
| Reduced K_{VS} coefficient | | 2.5 · 4.0 · 6.3 | | 6.3 | 8.0 | 16 | 32 | 80 | | 125 | | |
| Max. permissible differential pressure Δp | | 25 bar | | | | | | | | 20 bar | | 16 bar |
| x_{FZ} value | | 0.65 | 0.6 | 0.55 | 0.45 | 0.4 | 0.35 | | | | | |
| Type 2422 Valve - Balanced by a diaphragm | | | | | | | | | | | | |
| Valve size | DN | 65 | | | 80 | | | 100 | | | | |
| Valve travel | | 16 mm | | | | | | | | | | |
| K_{VS} coefficient | | 50 | | | 80 | | | 125 | | | | |
| Max. permissible differential pressure Δp | | 10 bar | | | | | | | | | | |
| x_{FZ} value | | 0.4 | | | 0.35 | | | | | | | |

¹⁾ With EN-GJS-400-18-LT: $\Delta p_{max.} = 14$ bar

²⁾ In combination with Type 2212 STL: 4 bar

Table 3-5: Materials · Valves · Material numbers according to DIN EN

| Type 2111 Valve · Unbalanced | | | | |
|---|---|--|--|--------------------------------|
| Valve size | DN 32 to 50 | DN 15 to 50 | | |
| Pressure rating | PN 16 | PN 25 | PN 40 | |
| Valve body | Cast iron EN-GJL-250 | Spheroidal graphite iron EN-GJS-400-18-LT | Cast steel 1.0619 | Cast stainless steel 1.4408 |
| Seat · Plug | Cr steel | | CrMo steel | CrNiMo steel |
| Plug stem · Spring | CrNi steel | | | |
| Bottom section | Cr steel | | | CrNi steel |
| Body gasket | Graphite on metal core | | | |
| Extension piece · Separating piece ³⁾ | Brass (for version free of non-ferrous metal: CrNi steel) | | | CrNi steel |
| Type 2422 Valve · Balanced by a bellows | | | | |
| Valve size | DN 15 to 150 | | | |
| Pressure rating | PN 16 | PN 16, 25 | PN 16, 25, 40 | |
| Valve body | Cast iron EN-GJL-250 | Spheroidal graphite iron EN-GJS-400-18-LT | Cast steel 1.0619 | Cast stainless steel 1.4408 |
| Seat | CrMo steel · Cr steel ⁴⁾ | | | CrNiMo steel |
| Plug ²⁾ | Up to DN 100 ¹⁾ | CrNiMo steel | | |
| | DN 125 to 250 | CrNiMo steel, plug with PTFE seal | | CrNiMo steel |
| Plug stem | CrNi steel | | | |
| Spring | CrNi steel | | | |
| Balancing bellows | CrNiMoTi steel · DN 125: CrNiMo steel | | | |
| Bellows housing/bottom section | Cr steel | | | CrNi steel |
| Body gasket | Graphite on metal core | | | |
| Extension piece · Separating piece ³⁾ | Brass (for version free of non-ferrous metal: CrNi steel) | | | CrNi steel |
| Type 2422 Valve · Balanced by a diaphragm | | | | |
| Valve size | DN 65 to 100 | | | |
| Pressure rating | PN 16 | | PN 25 | |
| Valve body | Cast iron EN-GJL-250 | | Spheroidal graphite iron EN-GJS-400-18-LT | |
| Seat | CrNiMo steel | | | |
| Plug | Brass, plug with EPDM soft seal | | | |
| Cover | 1.0619 | | | |
| Pressure balancing | Diaphragm plate CrNi steel · EPDM balancing diaphragm, max. 150 °C or NBR diaphragm, max. 80 °C | | | |

¹⁾ Optionally with soft seal with standard K_{VS} coefficients

²⁾ Soft-seated plug with EPDM ring for temperatures up to 150 °C

³⁾ Select the material of the accessories to match that of the main valve

⁴⁾ For DN 65 to 100 only

Design and principle of operation

Table 3-6: Materials · Control thermostats · Material numbers according to DIN EN

| Type 2231, Type 2232 and Type 2234 Control Thermostats | | | |
|--|-----------------|-------------------------------------|-----------------------|
| Version | | Standard version | Special version |
| Operating element | | Nickel-plated brass | |
| Sensor | Type 2231 | Bronze | – |
| | Type 2232 | Bronze | CrNiMoTi steel |
| | Type 2234 | Copper | |
| Capillary tube | | Copper | Plastic-coated copper |
| Thermowell | | | |
| G 1 threaded connection | Immersion tube | Bronze, steel, copper ²⁾ | |
| | Threaded nipple | Brass · Steel | |
| Flange connection ¹⁾ | Immersion tube | Steel | |
| | Threaded nipple | Steel | |

¹⁾ On request

²⁾ PN 16 only

Table 3-7: Dimensions and weights of Type 2111 Valves · Dimensions in mm · Weights in kg

| Type 2111 (Type 1) | | | | | | | |
|---|--------------|-------------------------|-----|-----|-------|------|------|
| Valve size | DN | 15 | 20 | 25 | 32 | 40 | 50 |
| Length L | | 130 | 150 | 160 | 180 | 200 | 230 |
| Body material EN-GJS-400-18-LT and EN-GJL-250 | | | | | | | |
| Height H | | 372 | | | 442 | | |
| Height H1 | | 82 | | | 152 | | |
| Weight ¹⁾ | Approx. | 4.0 kg | | | 10 kg | | |
| Body material 1.0619 and 1.4408 | | | | | | | |
| Height H | | 515 · 655 ²⁾ | | | | | |
| Height H1 | | 225 · 365 ²⁾ | | | | | |
| Weight ¹⁾ | kg (approx.) | 4 | 4.5 | 5.5 | 10 | 10.5 | 13.5 |

¹⁾ PN 16 body; +15 % for PN 25/40

²⁾ With extension piece

Table 3-8: Dimensions and weights of Type 2422 Valves · Dimensions in mm · Weights in kg

| Type 2422 Valve (Type 4 · Type 4u) · Balanced by a bellows | | | | | | | | | | | | | |
|--|--|-------------------------|-----|-----|-----|------|-----|-------------------------|-------------------------|-------------------------|--------------------------|-----|--|
| Valve size | DN | 15 | 20 | 25 | 32 | 40 | 50 | 65 | 80 | 100 | 125 | 150 | |
| Length L | | 130 | 150 | 160 | 180 | 200 | 230 | 290 | 310 | 350 | 400 | 480 | |
| Height H | Up to 220 °C (without extension piece) | 515 · 425 ²⁾ | | | | | | 590 · 500 ²⁾ | 645 · 555 ²⁾ | 750 · 660 ²⁾ | 880 · 790 ²⁾ | | |
| | Up to 350 °C (with extension piece) | 655 · 565 ²⁾ | | | | | | 730 · 640 ²⁾ | 785 · 695 ²⁾ | 890 · 800 ²⁾ | 1020 · 930 ²⁾ | | |
| Height H1 | Up to 220 °C (without extension piece) | 225 | | | | | | 300 | 355 | 460 | 590 | | |
| | Up to 350 °C (with extension piece) | 365 | | | | | | 440 | 495 | 600 | 730 | | |
| Height H2 | Forged steel | 53 | - | 70 | - | 92 | 98 | - | | | | | |
| | Other materials | 55 | | | 72 | | | 100 | 120 | 145 | 175 | | |
| Weight ¹⁾ | kg (approx.) | 5 | 5.5 | 6.5 | 13 | 13.5 | 16 | 27 | 32 | 40 | 70 | 113 | |

| Type 2422 Valve (Type 4 · Type 4u) · Balanced by a diaphragm | | | | | |
|--|--------------|-------------------------|--|-------------------------|-------------------------|
| Valve size | DN | 65 | | 80 | 100 |
| Length L | | 290 | | 310 | 350 |
| Height H | | 589 · 401 ²⁾ | | 590 · 402 ²⁾ | 626 · 418 ²⁾ |
| Height H1 | | 201 | | 202 | 218 |
| Height H2 | | 98 | | | 118 |
| Weight ¹⁾ | kg (approx.) | 30 | | 37.5 | 45 |

¹⁾ Body PN 16; +15 % for PN 25/40 · Type 4 and Type 4u without extension piece

²⁾ For Type 4u only

Table 3-9: Dimensions and weights of control thermostats · Dimensions in mm · Weights in kg

| Control thermostat | Type | 2231 | 2232 | 2234 |
|--------------------|--------------|-------------------|-------------------|------|
| Immersion depth T | | 290 ¹⁾ | 235 ¹⁾ | 460 |
| Weight | kg (approx.) | 3.2 | 4 | 3.7 |

¹⁾ Larger immersion depths on request

Design and principle of operation

Dimensional drawings

Type 2111 and Type 1 Valves

Body material EN-GJS-400-18-LT and EN-GJL-250

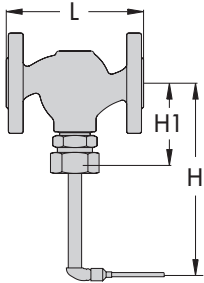

Body material 1.0619 and 1.4408

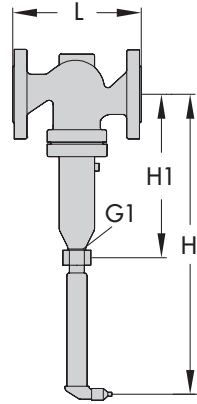

Type 2422 and Type 4 Valves

Balanced by a bellows

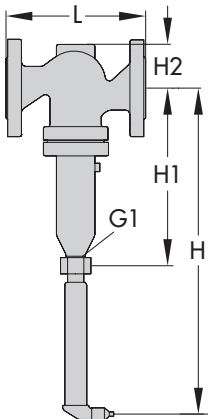

Balanced by a diaphragm

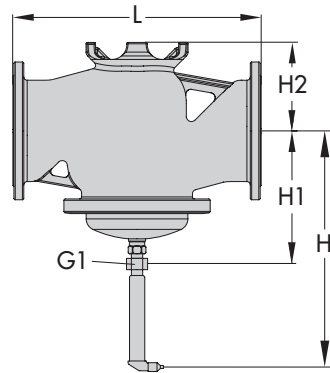
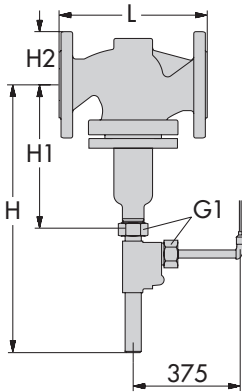

Fig. 3-4: Dimensions of Type 2111 Valve (Type 1) and Type 2422 Valve (Type 4)

Dimensional drawings

Type 2422 and Type 4 Valves

Balanced by a bellows



Balanced by a diaphragm

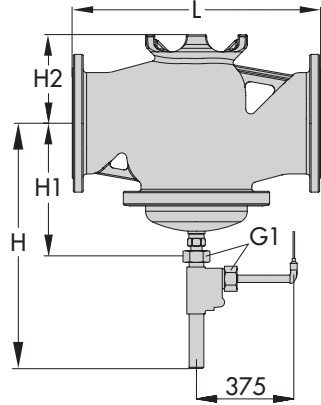

Types 2231 to 2234 Control Thermostats · Type 1, Type 4 and Type 4u

Type 2231

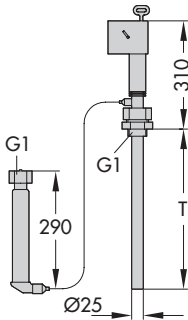

With integrated set point adjustment

Type 2232/2234 Thermostat

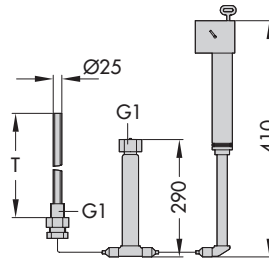

With separate set point adjustment

Fig. 3-5: Dimensions of Type 2422 Valve (Type 4u) and Types 2231 to 2234 Control Thermostats

Design and principle of operation

Dimensional drawings

Types 2232/2234. Clamps and perforated cover for wall mounting

To mount the set point adjuster or sensor to a wall, suitable clamps (photo) are available.
The clamps for the sensor are integrated into the perforated cover.

Clamp with bracket

For set point adjuster Item no.: 8395-0039

For sensor Item no.: 8395-0037

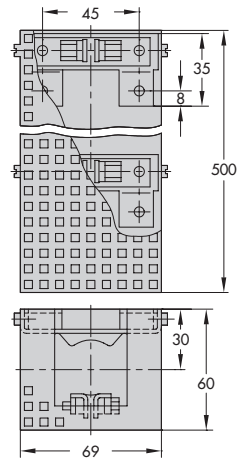

Extension piece

Standard version

L = approx. 140 mm, approx. 0.5 kg

With bellows (special version)

L = approx. 180 mm, approx. 0.6 kg

Separating piece with seals

L = approx. 55 mm, approx. 0.2 kg

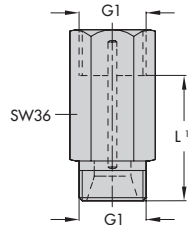

1) Add the dimension L to H and H1 when these accessories are used.

Type 2231/2232 · Thermowells

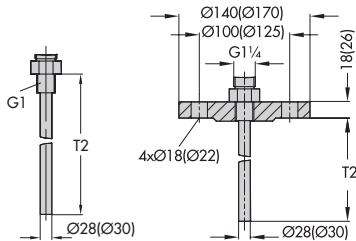

Type 2231/2232 · Thermowells for flammable gases (PN 100)

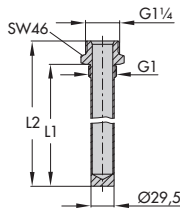

Type 2234 · Flange

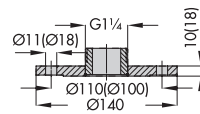

| Thermostat | 2231 | 2232 |
|--------------------|------|------|
| Immersion depth T2 | 325 | 250 |

| Thermostat | 2231 | 2232 |
|------------|------|------|
| Length L1 | 315 | 255 |
| Length L2 | 340 | 280 |

Flange PN 6; 140 mm outer diameter
Flange PN 40/DN 32
(dimensions in parentheses)

Fig. 3-6: Dimensions of accessories · Dimensions in mm

4 Shipment and on-site transport

The work described in this section is only to be performed by personnel appropriately qualified to carry out such tasks.

4.1 Accepting the delivered goods

After receiving the shipment, proceed as follows:

1. Check the scope of delivery. Check that the specifications on the valve and control thermostat nameplate match the specifications in the delivery note. See the 'Markings on the device' section for nameplate details.
2. Check the shipment for transportation damage. Report any damage to SAMSON and the forwarding agent (refer to delivery note).
3. Determine the weight and dimensions of the units to be lifted and transported in order to select the appropriate lifting equipment and lifting accessories. Refer to the transport documents and the 'Design and principle of operation' section.

4.1 Removing the packaging from the regulator

The components (valve, control thermostat and, if applicable, accessories) of the regulator are delivered separately.

Proceed as follows to lift and install the valve:

- Do not open or remove the packaging until immediately before lifting to install the regulator into the pipeline.
- Leave the regulator components in its transport container or on the pallet to transport it on site.
- Do not remove the protective caps from the inlet and outlet until immediately before installing the valve into the pipeline. They prevent foreign particles from entering the valve.
- Dispose and recycle the packaging in accordance with the local regulations.

4.2 Transporting and lifting the regulator

⚠ DANGER

Danger due to suspended loads falling.

- Stay clear of suspended or moving loads.
- Close off and secure the transport paths.

⚠ WARNING

Risk of injury due to incorrect lifting without the use of lifting equipment.

Lifting the regulator without the use of lifting equipment may lead to injuries (back injury in particular) depending on the weight of the regulator and/or control thermostat.

- Observe the occupational health and safety regulations valid in the country of use.
- Observe the guideline weight for manual handling: 15 to max. 55 kg per person taking into account age, gender and physical fitness.
- Refer to the 'Design and principle of operation' section for the weights of the regulator.

⚠ WARNING

Risk of personal injury due to the regulator tipping.

- Observe the regulator's center of gravity.
- Secure the regulator against tipping over or turning.

⚠ WARNING

Risk of lifting equipment tipping over and risk of damage to lifting accessories due to exceeding the rated lifting capacity.

- Only use approved lifting equipment and accessories whose minimum lifting capacity is higher than the weight of the valve (including control thermostat, if applicable).
- Refer to the 'Design and principle of operation' section for the weights.

💡 Tip

Our after-sales service can provide more detailed transport and lifting instructions on request.

4.2.1 Transporting the regulator

The regulator can be transported using lifting equipment (e.g. crane or forklift).

- Leave the regulator in its transport container or on the pallet to transport it.
- Observe the transport instructions.

Transport instructions

- Protect the regulator against external influences (e.g. impact).
- Do not damage the corrosion protection (paint, surface coatings). Repair any damage immediately.
- Protect the regulator against moisture and dirt.

- Protect the piping and any mounted valve accessories against damage.
- The permissible ambient temperature of standard regulators is -20 to $+80$ °C.

4.2.2 Lifting the regulator

To install a large regulator into the pipeline, use lifting equipment (e.g. crane or forklift) to lift it.

Lifting instructions

- Use a hook with safety latch to secure the slings from slipping off the hook during lifting and transporting (see Fig. 4-1).
- Secure slings against slipping.
- Make sure the slings can be removed after installation.
- Prevent the regulator from tilting or tipping.
- Do not leave loads suspended when interrupting work for longer periods of time.
- Make sure that the axis of the pipeline is always horizontal during lifting and the axis of the plug stem is always vertical.

Lifting

1. Attach one sling to the flange of the body and to the rigging equipment (e.g. hook) of the crane or forklift (see Fig. 4-1).
2. Carefully lift the regulator. Check whether the lifting equipment and accessories can bear the weight.

3. Move the regulator at an even pace to the site of installation.
4. Install the regulator into the pipeline (see the 'Installation' section).
5. After installation in the pipeline, check whether the regulator flanges are bolted tight.
6. Remove slings.

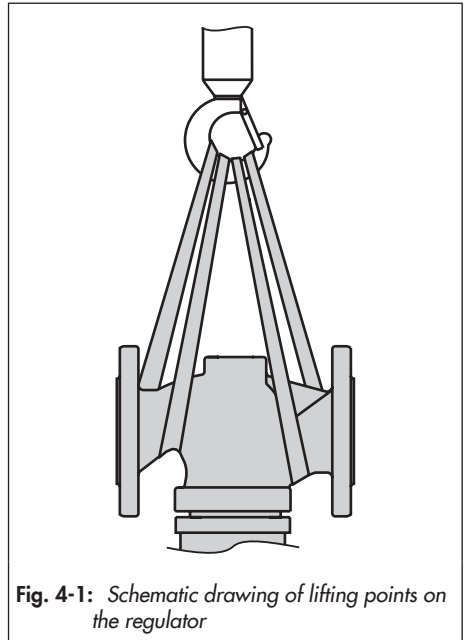

Fig. 4-1: Schematic drawing of lifting points on the regulator

4.3 Storing the regulator

NOTICE

Risk of regulator damage due to improper storage.

- Observe the storage instructions.
- Avoid long storage times.
- Contact SAMSON in case of different storage conditions or longer storage times.

Note

We recommend regularly checking the regulator and the prevailing storage conditions during long storage periods.

Storage instructions

- Protect the regulator against external influences (e.g. impact).
- Secure the regulator in the stored position against slipping or tipping over.
- Do not damage the corrosion protection (paint, surface coatings). Repair any damage immediately.
- Protect the regulator against moisture and dirt. Store it at a relative humidity of less than 75 %. In damp spaces, prevent condensation. If necessary, use a drying agent or heating.
- Make sure that the ambient air is free of acids or other corrosive media.
- The permissible storage temperature of standard regulators is -20 to +65 °C.

- Do not place any objects on the regulator.

Special storage instructions for elastomers

Elastomer, e.g. balancing diaphragm

- To keep elastomers in shape and to prevent cracking, do not bend them or hang them up.
- Store elastomers away from lubricants, chemicals, solutions and fuels.
- We recommend a storage temperature of 15 °C for elastomers.

Tip

SAMSON's After-sales Service can provide more detailed storage instructions on request.

5 Installation

The work described in this section is only to be performed by personnel appropriately qualified to carry out such tasks.

5.1 Installation conditions

Work position

The work position for the regulator is the front view onto all operating controls on the regulator (including any additional fittings) seen from the position of operating personnel.

Plant operators must ensure that, after installation of the device, the operating personnel can perform all necessary work safely and easily access the device from the work position.

Pipeline routing

The inlet and outlet lengths vary depending on several variables and process conditions and are intended as recommendations. Contact SAMSON if the lengths are significantly shorter than the recommended lengths.

To ensure that the regulator functions properly, proceed as follows:

- ➔ Observe the inlet and outlet lengths (see Table 5-2). Contact SAMSON if the regulator conditions or state of the medium process deviate.
- ➔ Install the regulator free of stress and with the least amount of vibrations as possible. Read information under "Mounting position" and "Support or suspension" in this section.

- ➔ For media with a tendency to condensate, install the pipeline with a slight downward slope on both sides so that the condensate can drain properly. If the pipeline upstream and downstream of the regulator run vertically upwards, an automatic drainage is required.

- ➔ Install the regulator allowing sufficient space to remove the control thermostat and valve or to perform service work on them.

Mounting position

To ensure that the regulator functions properly, proceed as follows:

- ➔ Standard mounting position: install the control thermostat suspended downward in horizontal pipelines (see Fig. 5-1 and Fig. 5-2).
- ➔ Make sure the direction of flow matches the direction indicated by the arrow on the body.
- ➔ Contact SAMSON if the mounting position is not as specified above.

NOTICE

Damage due to freezing.

Protect the regulator from icing up when controlling media that can freeze. Unless the regulator is installed in locations where no frost occurs, remove the regulator from the pipeline when the plant is shut down.

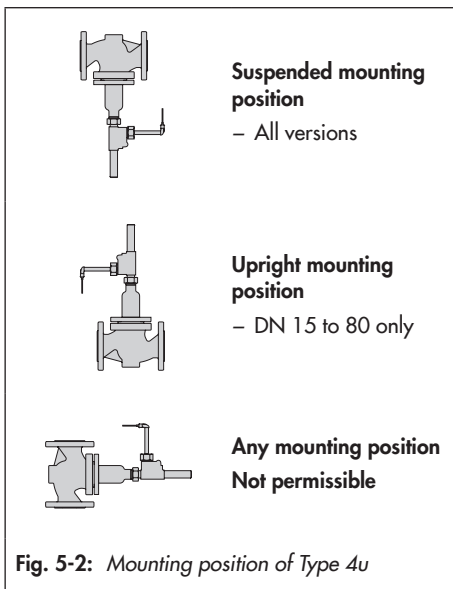
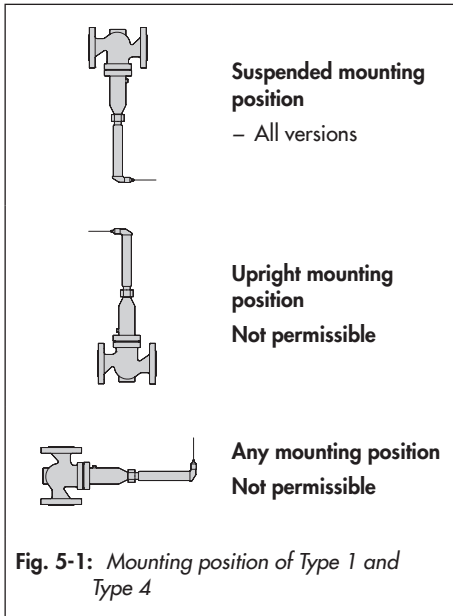

Support or suspension

i Note

The plant engineering company is responsible for selecting and implementing a suitable support or suspension of the installed regulator and the pipeline.

Depending on the regulator version and mounting position, the valve, actuator and control thermostat must be supported or suspended.

! NOTICE

Do not attach supports directly to the valve or control thermostat.

Temperature sensor

! NOTICE

Galvanic corrosion due to incorrectly selected materials of the mounting parts.

On installing the sensor or thermowell, only combine the same kind of materials (e.g. stainless steel with stainless steel or copper together with other copper materials).

The temperature sensor, even together with a thermowell, can be installed in any position as required. However, make sure its entire length is immersed in the process medium to be controlled. It must be installed in a location where overheating or considerable idling times cannot occur.

i Note

If the sensor is to be used with a thermowell, only use original SAMSON thermowells.

Weld on a pipe socket with female thread (socket-weld design to fit the screw gland of the sensor) of approx. 40 mm in length at the place of installation (this also applies when a thermowell is used).

→ Seal the screw gland of the sensor.

Installation with thermowell

When a thermowell is used, a welding socket with G 1 female thread must be used.

1. Remove the double nipple (17) or thermowell (if used) from the sensor (19) and seal it into the welded socket.
2. Adjust the highest possible set point at the set point adjuster (12.2) using the key (12.1).
3. Insert the sensor with the associated seal into the double nipple or thermowell. Secure it with the coupling nut (16). The entire length of the temperature sensor (19) or thermowell must be immersed in the process medium.

We recommend filling the free space between sensor and thermowell with oil or, when installed horizontally, with grease or any other heat transfer medium to avoid delays during heat transmission. Observe the thermal expansion of the filling medium. Allow some space for expansion or slightly loosen sensor nut for pressure compensation.

For temperature regulators with safety temperature limiter (TR/STL), install the sensor of the limiter near the sensor of the regulator.

Dynamic behavior of the control thermostats

The dynamics of the regulator are mainly determined by the response of the sensor with its characteristic time constant (see Table 5-1).

Table 5-1: Time constants of SAMSON thermostats (measurements with water)

| Principle of operation | Type ... Thermostat | Time constant [s] | |
|------------------------|------------------------|--------------------|-----------------|
| | | Without Thermowell | With Thermowell |
| Liquid expansion | 2231 | 70 | 120 |
| | 2232 | 65 | 110 |
| | 2234 | 15 | – ¹⁾ |
| | 2213 | 70 | 120 |
| Adsorption | 2212 | – ¹⁾ | 40 |

¹⁾ Not permissible

Capillary tube

Carefully run the capillary tube (11) without bending or twisting it. Avoid locations with considerable ambient temperature fluctuations along the entire length of the tube.

i Note

Do not damage or shorten the capillary tube. Roll up any capillary tube that is not used. The smallest permissible bending radius is 50 mm.

5.2 Preparation for installation

Valve and control thermostat can be assembled before or after the valve has been installed in the pipeline. We recommend first installing the valve without the control thermostat into the pipeline.

Before installation, make sure the following conditions are met:

- The valve is clean.
- The valve, control thermostat and all piping are not damaged.
- Install a strainer upstream of the regulator.
- The valve data on the nameplate (type designation, valve size, material, pressure rating and temperature range) match the plant conditions (size and pressure rating of the pipeline, medium temperature etc.). See the 'Markings on the device' section for nameplate details.
- The requested or required additional fittings (see the 'Design and principle of operation' section) have been installed or prepared as necessary before installing the valve.

Proceed as follows:

- ➔ Lay out the necessary material and tools to have them ready during installation work.
- ➔ For steam applications, dry the pipelines. Moisture will damage the inside of the regulator.
- ➔ Check any mounted thermometers to make sure they function properly.

5.3 Installation

The components (valve, control thermostat and, if applicable, accessories) of the SAMSON regulator are delivered separately. Upon delivery, the separate components must be assembled together. The activities listed below are necessary for installation and before start-up of the regulator.

⚠ WARNING

Risk of injury due to incorrect lifting without the use of lifting equipment.

Lifting the regulator without the use of lifting equipment may lead to injuries (back injury in particular) depending on the weight of the regulator and/or control thermostat.

- ➔ *Observe the occupational health and safety regulations valid in the country of use.*
 - ➔ *Observe the guideline weight for manual handling: 15 to max. 55 kg per person taking into account age, gender and physical fitness.*
 - ➔ *Refer to the 'Design and principle of operation' section for the weights of the regulator and control thermostat.*
-

⚠ DANGER

Danger due to suspended loads falling.

- ➔ *Stay clear of suspended or moving loads.*
 - ➔ *Close off and secure the transport paths.*
-

Table 5-2: Inlet and outlet lengths

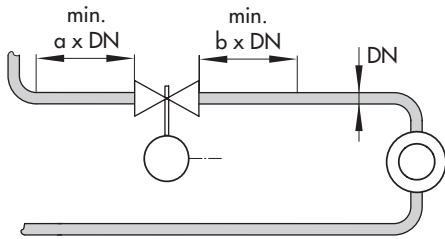

a Inlet length
b Outlet length

| State of process medium | Valve conditions | Inlet length a | Outlet length b |
|-------------------------|--|----------------|-----------------|
| Gas | $Ma \leq 0.3$ | 2 | 4 |
| Vapors ¹⁾ | $Ma \leq 0.3$ | 2 | 4 |
| Liquid | Free of cavitation/ $w < 3 \text{ m/s}$ | 2 | 4 |
| | Cavitation producing noise/ $w \leq 3 \text{ m/s}$ | 2 | 4 |

¹⁾ No wet steam

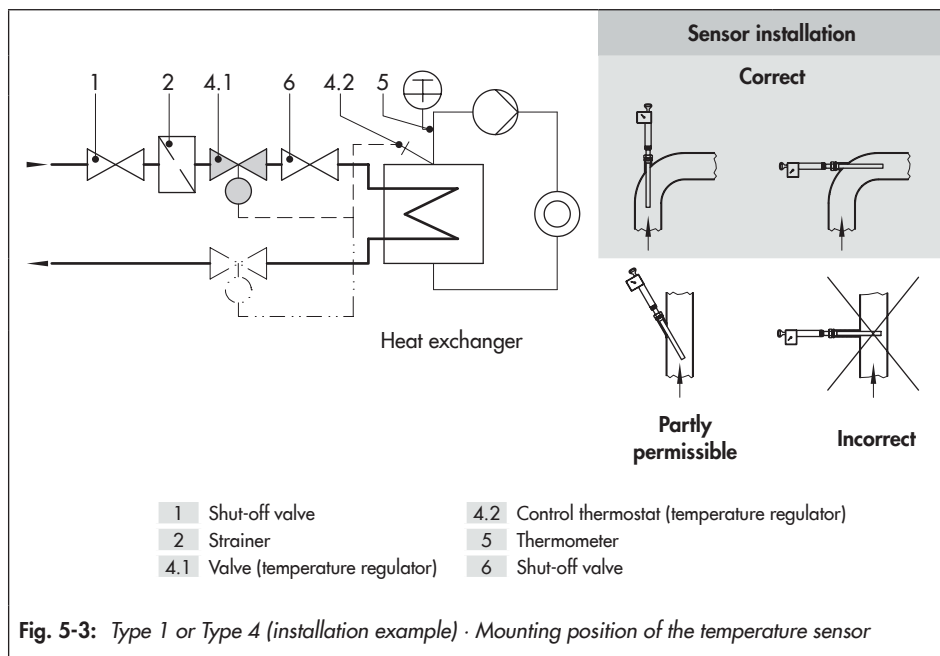

⚠ WARNING

Risk of lifting equipment tipping over and risk of damage to lifting accessories due to exceeding the rated lifting capacity.

- Only use approved lifting equipment and accessories whose minimum lifting capacity is higher than the weight of the valve (including control thermostat, if applicable).
- Refer to the 'Design and principle of operation' section for the weights.

⚠ WARNING

Risk of personal injury due to the regulator tipping.

- Observe the regulator's center of gravity.
- Secure the regulator against tipping over or turning.

ⓘ NOTICE

Risk of regulator damage due to the use of unsuitable tools.

- Only use tools approved by SAMSON (see 'Tools' in Annex).

ⓘ NOTICE

Risk of regulator damage due to the use of unsuitable lubricants.

- Only use lubricants approved by SAMSON (see 'Lubricants' in Annex).

ⓘ NOTICE

Risk of regulator damage due to excessively high or low tightening torques.

Observe the specified torques when tightening regulator components. Excessive tightening torques lead to parts wearing out more quickly. Parts that are too loose may cause leakage.

- Observe the specified tightening torques (see 'Tightening torques' in Annex).

5.4 Installing the regulator

i Note

Do **not** install the temperature regulator between a pressure reducing valve and its control line connection.

5.4.1 Installing the valve

The regulator can be installed into the downstream pressure pipe (return flow pipe) or the upstream pressure pipe (flow pipe) of the plant. See installation examples in Fig. 5-3.

1. Close the shut-off valves upstream and downstream of the regulator while the regulator is being installed.
2. Remove the protective caps from the valve ports before installing the valve.
3. Lift the valve using suitable lifting equipment to the site of installation. Observe the flow direction through the valve. The arrow on the valve indicates the direction of flow.

4. Make sure that the correct flange gaskets are used.
5. Bolt the pipe to the valve free of stress.

5.4.2 Installing the control thermostat

i Note

Detailed instructions to install the control thermostats are given in ► EB 2231.

1. Fasten the operating element of the control thermostat on the valve using the coupling nut.

If necessary, use the set point adjuster to adjust the highest possible set point, causing the pin of the operating element to retract.

Observe the specified tightening torques (see 'Tightening torques' in Annex).

2. If applicable, mount the thermowell. Insert the thermowell in the socket installed on site. Observe the specified tightening torques (see 'Tightening torques' in Annex).

5.4.3 Installing the reversing device

→ See Fig. 5-5

i Note

The reversing device (for Type 4u) can only be attached to the valve when the stem is fully retracted.

The spring (8) of the reversing device is pretensioned upon delivery over the lever (4) using a wooden bolt (5) with washer (6) and coupling nut (7).

Procedure

1. Screw the pretensioned reversing device to the bottom section of the valve.
2. As the device is pretensioned, carefully unscrew the coupling nut (7) and remove it from the reversing device together with the wooden bolt (5) and washer (6).
3. Adjust the highest possible set point at the set point adjuster to cause the pin of the operating element to retract.
4. Screw the operating element onto the reversing device (in place of the coupling nut (7)).

i Note

Keep the wooden bolt and washer for later use.

They can be used, for example to pretension the reversing device again if it needs to be reinstall after disassembly.

5.5 Cleaning the pipeline

We recommend additionally flushing the pipeline with installed regulator before start-up.

- Observe the mesh size of the upstream strainer for the maximum particle size. Use strainers to suit the process medium.
- Check the strainer for dirt each time the pipeline is flushed and clean it, if necessary.
- Before flushing the plant, open all consumers to guarantee a high flow rate.

If the regulator malfunctions due to clogging after flushing the pipeline, proceed as described in the 'Troubleshooting' section.

5.6 Testing the regulator

⚠ DANGER

Risk of bursting due to incorrect opening of pressurized equipment or components.

Regulators and pipelines are pressure equipment that may burst when handled incorrectly. Flying projectile fragments or the release of process medium under pressure can cause serious injury or even death.

Before working on the regulator:

- *Depressurize all plant sections concerned and the regulator.*
 - *Drain the process medium from all the plant sections concerned as well as the valve.*
-

⚠ WARNING

Risk of personal injury due to pressurized components and process medium being discharged.

Incorrect opening of pressure equipment or mounting parts may lead to the process medium escaping to the atmosphere.

- *Do not loosen the control thermostat while the valve is pressurized.*
 - *Do not start up the regulator until all parts have been mounted.*
-

⚠ WARNING

Risk of hearing loss or deafness due to loud noise.

Noise emission (e.g. cavitation) may occur during operation caused by the process medium and the operating conditions.

➔ Wear hearing protection when working near the regulator. Follow the instructions given by the plant operator.

⚠ WARNING

Risk of burn injuries due to hot or very cold components and pipelines.

Depending on the process medium, valve components and pipelines may get very hot or cold and cause burn injuries.

➔ Wear protective clothing and safety gloves.

The regulator components are delivered by SAMSON ready for use. To test the regulator functioning before start-up or putting back the regulator into operation, perform the following tests:

5.6.1 Leak test

The plant operator is responsible for performing the leak test and selecting the test method. The leak test must comply with the requirements of the national and international standards that apply at the site of installation.

💡 Tip

SAMSON's After-sales Service can support you to plan and perform a leak test for your plant.

1. Install the regulator into the pipeline. See section "Installation".
2. Apply the required test pressure.
3. Check the regulator for leakage to the atmosphere.
4. Depressurize the pipeline section and regulator.
5. Rework any parts that leak and repeat the leak test.

5.6.2 Pressure test

NOTICE

Risk of valve damage due to a sudden pressure increase and resulting high flow velocities.

– Slowly open the shut-off valves.

Note

The plant operator is responsible for performing the pressure test. SAMSON's After-sales Service can support you to plan and perform a pressure test for your plant.

Pressure test with mounted control thermostat

During the pressure test, make sure the following conditions are met:

- Do not allow the pressure to exceed the 1.5 times the pressure rating of the valve body.
- Do not apply a pressure higher than the maximum specified pressure rating or maximum operating pressure to thermostat or sensor of the control thermostat (see Table 3-1 in the 'Design and principle of operation' section).
- The valve must remain open. Therefore, adjust the lowest temperature set point to ensure that the regulator does not close.
- Make sure that the pressure rises simultaneously upstream and downstream of the regulator to avoid damaging the balancing bellows or the balancing diaphragm.

Pressure test without mounted control thermostat

If the valve is not sealed off, the test medium escapes at the connection where the control thermostat is connected to the valve. It is not possible to perform a pressure test on the valve in this case (see Fig. 5-4).

- Seal off the valve using a coupling nut (0250-1037) with seal (0340-1962).



Fig. 5-4: *Medium escaping when a control thermostat is not mounted on the valve*

5.6.3 Filling the plant

Open the shut-off valves slowly over a time period of several minutes preferably starting from the upstream pressure side to fill the plant.

NOTICE

Risk of regulator damage due to steam hammering.

Steam hammering is possible when the process medium is a liquid with a boiling point at atmospheric pressure.

→ *Open the shut-off valves slowly preferably starting from the downstream side to fill the plant over a time period of several minutes.*

5.7 Insulation

To insulate cold or heated systems, we recommend first filling the plant and carefully rinsing it. The regulator must not yet be insulated at this stage.

NOTICE

Risk of regulator damage due to incorrect insulation.

→ *Only insulate the regulator up to the control thermostat for medium temperatures below 0 °C/32 °F or above 80 °C/175 °F.*

1. Start up the plant and adjust the set point (see the 'Start-up' section).

2. Shut down the plant again.

Cooling applications: allow the regulator to heat up until all the condensation water has dried off.

Heating applications: allow the regulator to cool down.

3. Insulate the regulator and pipes conveying the process medium using insulation material with a water vapor barrier. If a capillary tube of the control thermostat is to be routed through the insulation, special care must be taken with the sealing since slight changes in shape may occur. The insulation thickness depends on the medium temperature and the ambient conditions. 50 mm is a typical thickness.

5.8 Mounting accessories

WARNING

Risk of personal injury due to pressurized components and process medium being discharged.

Incorrect opening of pressure equipment or mounting parts may lead to the process medium escaping to the atmosphere.

→ *Do not loosen the control thermostat while the valve is pressurized.*

→ *Do not start up the regulator until all parts have been mounted.*

– The **extension piece** is installed between valve and thermostat to protect the operating element against high temperatures.

Installation

- The **separating piece** is installed between the valve and thermostat to protect the operating element against excessively high pressures in the plant. In stainless steel regulators, it also separates the operating element made free of non-ferrous metals from the medium in the valve.
- The **double adapter** allows a further thermostat or a manual adjuster.

A thermostat can be changed on site to install an extension piece, separating piece or double adapter.

How to proceed:

1. Adjust the highest possible temperature set point, causing the pin of operating element to detach itself from the plug stem of the valve.
2. Unscrew the operating element.
3. Screw extension piece, separating piece or double adapter onto the valve body. Remount the operating element.

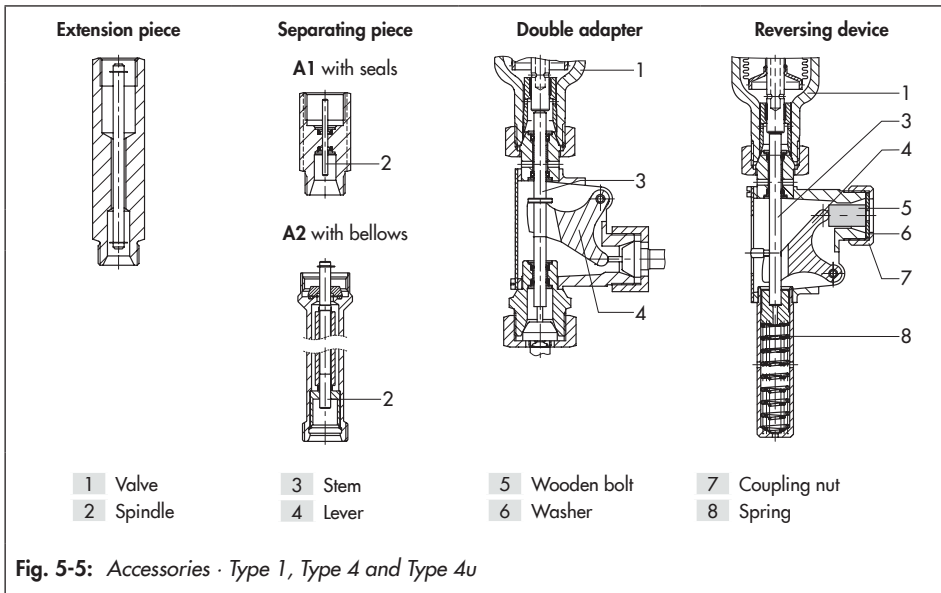

6 Start-up

The work described in this section is only to be performed by personnel appropriately qualified to carry out such tasks.

⚠ WARNING

Risk of personal injury due to pressurized components and process medium being discharged.

Incorrect opening of pressure equipment or mounting parts may lead to the process medium escaping to the atmosphere.

- *Do not loosen the control thermostat while the valve is pressurized.*
- *Do not start up the regulator until all parts have been mounted.*

⚠ WARNING

Risk of burn injuries due to hot or cold components and pipeline.

Regulator components and the pipeline may become very hot or cold. Risk of burn injuries.

- *Allow components and pipelines to cool down or warm up to the ambient temperature.*
- *Wear protective clothing and safety gloves.*

⚠ WARNING

Risk of hearing loss or deafness due to loud noise.

Noise emission (e.g. cavitation) may occur during operation caused by the process medium and the operating conditions.

- *Wear hearing protection when working near the valve. Follow the instructions given by the plant operator.*

Before start-up or putting the device back into service, make sure the following conditions are met:

- The regulator is properly installed into the pipeline (see the 'Installation' section).
- The leak and function tests have been completed successfully (see the 'Testing the regulator' section).
- The prevailing conditions in the plant section concerned meet the regulator sizing requirements (see information under 'Intended use' in the 'Safety instructions and measures' section).

6.1 Start-up and putting the device back into operation

1. Depending on the field of application, allow the regulator to cool down or warm up to reach ambient temperature before start up.
2. Slowly open the shut-off valves in the pipeline. Slowly opening these valves prevents a sudden surge in pressure and high flow velocities which can damage the valve.
3. Check the regulator to ensure it functions properly.

6.2 Starting up the plant when vapors and liquids are controlled

For media that do not reach their boiling point:

1. Open the shut-off valves **slowly** over a time period of several minutes starting from the upstream pressure side. Fill the plant with the medium. Afterwards, open all the valves on the consumer side (downstream of the regulator).
2. Fill the plant slowly with the process medium. Avoid pressure surges.
3. Make sure that the pressure rises simultaneously upstream and downstream of the regulator to avoid damaging the balancing bellows or diaphragm.

4. Check the adjusted temperature set point at the thermometer installed near the temperature sensor.

6.3 Starting up the plant when vapors are controlled

For media that reach their boiling point:

- Completely drain and dry steam lines to prevent water hammering.
1. Open the shut-off valves **slowly** starting from the downstream side to avoid steam hammering. Afterwards open the shut-off valves upstream pressure of the regulator.
 2. Slowly allow the steam to enter the plant to ensure that the pipes and valves warm up evenly and to avoid excessive flow velocities.
 3. Before the full capacity is reached, drain off the start-up condensate.
 4. Make sure that the air contained in the plant escapes as quickly as possible.
 5. Make sure that the pressure rises simultaneously upstream and downstream of the regulator to avoid damaging the balancing bellows.
 6. Avoid pressure surges.
 7. Check the adjusted temperature set point at the thermometer installed near the temperature sensor.

7 Operation

Immediately after completing start-up or placing the regulator back into service (see the 'Start-up' section), the regulator is ready for use.

⚠ WARNING

Risk of burn injuries due to hot or cold components and pipeline.

Regulator components and the pipeline may become very hot or cold. Risk of burn injuries.

- Allow components and pipelines to cool down or warm up to the ambient temperature.
- Wear protective clothing and safety gloves.

⚠ WARNING

Risk of personal injury due to pressurized components and process medium being discharged.

Incorrect opening of pressure equipment or mounting parts may lead to the process medium escaping to the atmosphere.

- Do not loosen the control thermostat while the valve is pressurized.
- Do not start up the regulator until all parts have been mounted.

⚠ WARNING

Risk of hearing loss or deafness due to loud noise.

Noise emission (e.g. cavitation) may occur during operation caused by the process medium and the operating conditions.

- Wear hearing protection when working near the valve. Follow the instructions given by the plant operator.

7.1 Adjusting the temperature set point

Adjust the required set point by turning the set point adjuster with the key (12.1) by hand.

1. Slowly open the hand-operated shut-off valve downstream of the valve and then the shut-off valve upstream of the valve.
2. Adjust the set point at set point dial (13) using the set point adjuster (12.2).

Set point adjuster

- Turn the key (12.1) clockwise (↻) to increase the temperature set point.
 - Turn the key (12.1) counterclockwise (↺) to reduce the temperature set point.
3. Monitor the temperature at the thermometer (4) installed on the downstream side on site.

i Note

Higher set point temperatures can be adjusted in increments as required. However, to lower the set point temperature, proceed in steps of 10 to 20 °C. When doing so, wait for the process medium to cool down before continuing. Watch the thermometer.

7.2 Correcting the set point dial

There are many ways to combine the temperature regulators with thermostats that have varying proportional control action. As a result, the temperature adjusted on the dial often deviates from the actual temperature (measured by a reference thermometer).

The temperature can be corrected by turning the dial housing:

1. Undo the screw labeled "Korrektur" on the back of the dial housing.
2. Turn the entire dial housing until the dial shows the same temperature as the reference thermometer.

Viewed from the front with the dial housing on top. A 360° turn corresponds to a set point change of approx. 1.5 °C.

7.3 Excess temperature safeguard of the thermostat

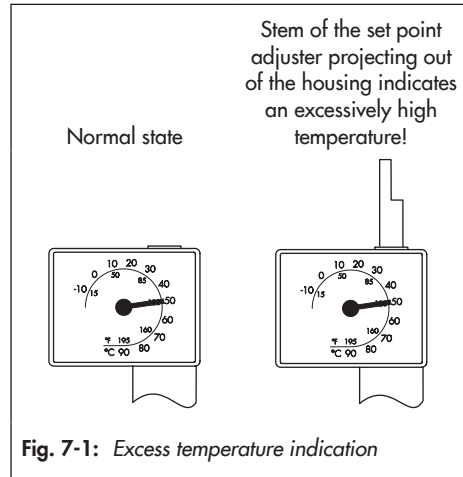

Fig. 7-1: Excess temperature indication

The temperature will exceed the adjusted limit if the valve cannot close due to dirt particles lodged between the seat and plug or due to a defective bellows. In this case, the excess temperature safeguard responds. The stem of the set point adjuster projecting out of the housing indicates an excessively high temperature at the sensor meaning a malfunction exists (see Fig. 7-1).

The regulator must be repaired or serviced.

8 Malfunctions

8.1 Troubleshooting

| Malfunction | Possible reasons | Recommended action |
|--|---|--|
| Temperature regulators for heating applications · Type 1 and Type 4 | | |
| Temperature at the sensor exceeds the set point | Foreign particles blocking the plug | <ul style="list-style-type: none"> → Remove foreign particles. → Replace damaged parts. → Contact SAMSON's After-sales Service. |
| | Seat and plug are worn or leak. | <ul style="list-style-type: none"> → Replace the damaged seat and plug. → Contact SAMSON's After-sales Service. |
| | Control thermostat defective | <ul style="list-style-type: none"> → Replace the control thermostat. |
| | Stem projecting out of the set point adjuster due to excess temperature at the sensor | <ul style="list-style-type: none"> → The regulator must be repaired or serviced. → Contact SAMSON's After-sales Service. |
| | Regulator or K_{VS}/C_V coefficient too large | <ul style="list-style-type: none"> → Check the sizing. → Change K_{VS}/C_V coefficient, if necessary or install a different sized regulator. → Contact SAMSON's After-sales Service. |
| | Sensor installed incorrectly. | <ul style="list-style-type: none"> → Immerse the temperature sensor with its entire immersion depth in the process medium. → Avoid an installation site where idle times or heat buildup can occur. |
| | Sensor installed in the wrong location. | <ul style="list-style-type: none"> → Change the mounting position. |
| Temperature fluctuates | Regulator or K_{VS}/C_V coefficient too large | <ul style="list-style-type: none"> → Check the sizing. → Change K_{VS}/C_V coefficient, if necessary or install a different sized regulator. → Contact SAMSON's After-sales Service. |
| | Sensor installed incorrectly. | <ul style="list-style-type: none"> → Immerse the temperature sensor with its entire immersion depth in the process medium. → Avoid an installation site where idle times or heat buildup can occur. |
| | Sensor installed in the wrong location. | <ul style="list-style-type: none"> → Change the mounting position. |
| Jerky control response | Increased friction, e.g. due to foreign particles between seat and plug | <ul style="list-style-type: none"> → Remove foreign particles. → Replace damaged parts. → Contact SAMSON's After-sales Service. |

Malfunctions

| Malfunction | Possible reasons | Recommended action |
|--|--|---|
| Temperature regulators for heating applications · Type 1 and Type 4 | | |
| Temperature at the sensor does not reach the set point | Regulator installed against the flow | → Install the regulator so that the direction of flow matches the direction indicated by the arrow on the body. |
| | Safety device (e.g. safety temperature limiter) has been triggered | → Check plant. If necessary, unlock safety device. |
| | Regulator or K_{VS}/C_V coefficient too small | → Check the sizing. → Change K_{VS}/C_V coefficient, if necessary or install a different sized regulator. → Contact SAMSON's After-sales Service. |
| | Insufficient heating energy available | → Draw up an energy balance. |
| | Foreign particles blocking the plug | → Remove foreign particles. → Replace damaged parts. → Contact SAMSON's After-sales Service. |
| | Sensor installed incorrectly. | → Immerse the temperature sensor with its entire immersion depth in the process medium. → Avoid an installation site where idle times or heat buildup can occur. |
| | Sensor installed in the wrong location. | → Change the mounting position. |
| | Strainer blocked | → Clean the strainer. |
| Slow control response | Time constant is too large for the control loop | → Fill the thermowell with thermal paste or remove the thermowell. → Contact SAMSON's After-sales Service. |
| | Sensor installed incorrectly. | → Immerse the temperature sensor with its entire immersion depth in the process medium. → Avoid an installation site where idle times or heat buildup can occur. |
| Loud noises | High flow velocity, cavitation | → Check the sizing. → Install larger regulator, if necessary. |
| Leak between control thermostat and valve | Coupling nut tightened incorrectly | → Check the specified tightening torque (see 'Tightening torques' in Annex). |

| Malfunction | Possible reasons | Recommended action |
|--|---|--|
| Temperature regulators for cooling applications · Type 4u | | |
| Temperature at the sensor does not reach the set point | Foreign particles blocking the plug | <ul style="list-style-type: none"> → Remove foreign particles. → Replace damaged parts. → Contact SAMSON's After-sales Service. |
| | Seat and plug are worn or leak. | <ul style="list-style-type: none"> → Replace the damaged seat and plug. → Contact SAMSON's After-sales Service. |
| | Control thermostat defective | <ul style="list-style-type: none"> → Replace the control thermostat. |
| | Regulator or K_{VS}/C_V coefficient too large | <ul style="list-style-type: none"> → Check the sizing. → Change K_{VS}/C_V coefficient, if necessary or install a different sized regulator. → Contact SAMSON's After-sales Service. |
| | Sensor installed incorrectly. | <ul style="list-style-type: none"> → Immerse the temperature sensor with its entire immersion depth in the process medium. → Avoid an installation site where idle times or heat buildup can occur. |
| | Sensor installed in the wrong location. | <ul style="list-style-type: none"> → Change the mounting position. |
| Temperature fluctuates | Regulator or K_{VS}/C_V coefficient too large | <ul style="list-style-type: none"> → Check the sizing. → Change K_{VS}/C_V coefficient, if necessary or install a different sized regulator. → Contact SAMSON's After-sales Service. |
| | Sensor installed incorrectly. | <ul style="list-style-type: none"> → Immerse the temperature sensor with its entire immersion depth in the process medium. → Avoid an installation site where idle times or heat buildup can occur. |
| | Sensor installed in the wrong location. | <ul style="list-style-type: none"> → Change the mounting position. |
| Slow control response | Time constant is too large for the control loop | <ul style="list-style-type: none"> → Fill the thermowell with thermal paste or remove the thermowell. → Contact SAMSON's After-sales Service. |
| | Sensor installed incorrectly. | <ul style="list-style-type: none"> → Immerse the temperature sensor with its entire immersion depth in the process medium. → Avoid an installation site where idle times or heat buildup can occur. |

Malfunctions

| Malfunction | Possible reasons | Recommended action |
|--|---|---|
| Temperature regulators for cooling applications · Type 4u | | |
| Temperature at the sensor exceeds the set point | Regulator installed against the flow | → Install the regulator so that the direction of flow matches the direction indicated by the arrow on the body. |
| | Safety device (e.g. safety temperature limiter) has been triggered | → Check plant. If necessary, unlock safety device. |
| | Regulator or K_{VS}/C_V coefficient too small | → Check the sizing. → Change K_{VS}/C_V coefficient, if necessary or install a different sized regulator. → Contact SAMSON's After-sales Service. |
| | Insufficient cooling energy available | → Draw up an energy balance. |
| | Foreign particles blocking the plug | → Remove foreign particles. → Replace damaged parts. → Contact SAMSON's After-sales Service. |
| | Sensor installed incorrectly. | → Immerse the temperature sensor with its entire immersion depth in the process medium. → Avoid an installation site where idle times or heat buildup can occur. |
| | Sensor installed in the wrong location. | → Change the mounting position. |
| | Strainer blocked | → Clean the strainer. |
| Jerky control response | Increased friction, e.g. due to foreign particles between seat and plug | → Remove foreign particles. → Replace damaged parts. → Contact SAMSON's After-sales Service. |
| Loud noises | High flow velocity, cavitation | → Check the sizing. → Install larger regulator, if necessary. |
| Leak between control thermostat and valve | Coupling nut tightened incorrectly | → Check the specified tightening torque (see 'Tightening torques' in Annex). |

i Note

Contact SAMSON's After-sales Service for malfunctions not listed in the table.

The malfunctions listed in section 8.1 are caused by mechanical faults and incorrect regulator sizing. In the simplest case, the functioning can be restored following the recommended action. Special tools may be required to rectify the fault.

Exceptional operating and installation conditions may lead to changed situations that may affect the control response and lead to malfunctions. For troubleshooting, the conditions, such as installation, process medium, temperature and pressure conditions, must be taken into account.

**Tip**

SAMSON's After-sales Service can support you in drawing up an inspection and test plan for your plant.

8.2 Emergency action

Plant operators are responsible for emergency action to be taken in the plant.

We recommend removing the regulator from the pipeline before repairing it.

In the event of a regulator malfunction:

1. Close the shut-off valves upstream and downstream of the regulator to stop the process medium from flowing through the regulator.
2. Perform troubleshooting (see section 8.1).
3. Rectify those malfunctions that can be remedied based on the instructions provided here. Contact SAMSON's After-sales Service in all other cases.

Putting the regulator back into operation after a malfunction

See the 'Start-up' section.

9 Servicing

The regulator does not require any maintenance. Nevertheless, it is subject to natural wear, particularly at the seat, plug and control thermostat. Depending on the operating conditions, check the regulator at regular intervals to avoid possible malfunctions. Plant operators are responsible for drawing up an inspection and test plan. Details on faults and how to remedy them can be found in the 'Malfunctions' section.

The work described in this section is only to be performed by personnel appropriately qualified to carry out such tasks.

We recommend removing the regulator from the pipeline before performing any maintenance or service work.

⚠ DANGER

Danger due to suspended loads falling.

- Stay clear of suspended or moving loads.
- Close off and secure the transport paths.

⚠ WARNING

Risk of personal injury due to residual process medium in the regulator.

While working on the regulator, residual process medium can escape and, depending on its properties, may lead to personal injury, e.g. (chemical) burns.

- Wear protective clothing, safety gloves and eye protection.
-

⚠ WARNING

Risk of burn injuries due to hot or cold components and pipeline.

Regulator components and the pipeline may become very hot or cold. Risk of burn injuries.

- Allow components and pipelines to cool down or warm up to the ambient temperature.
 - Wear protective clothing and safety gloves.
-

⚠ WARNING

Risk of personal injury due to the regulator tipping.

- Observe the regulator's center of gravity.
 - Secure the regulator against tipping over or turning.
-

⚠ WARNING

Risk of injury due to incorrect lifting without the use of lifting equipment.

Lifting the regulator without the use of lifting equipment may lead to injuries (back injury in particular) depending on the weight of the regulator and/or actuator.

- Observe the occupational health and safety regulations valid in the country of use.
 - Observe the guideline weight for manual handling: 15 to max. 55 kg per person taking into account age, gender and physical fitness.
-

Servicing

→ Refer to the 'Design and principle of operation' section for the weights of the valve and control thermostat.

⚠ WARNING

Risk of lifting equipment tipping over and risk of damage to lifting accessories due to exceeding the rated lifting capacity.

- Only use approved lifting equipment and accessories whose minimum lifting capacity is higher than the weight of the valve (including actuator and packaging, if applicable).
 - Refer to the 'Design and principle of operation' section for the weights.
-

ⓘ NOTICE

Risk of regulator damage due to the use of unsuitable tools.

- Only use tools approved by SAMSON (see 'Tools' in Annex).
-

ⓘ NOTICE

Risk of regulator damage due to excessively high or low tightening torques.

Observe the specified torques when tightening regulator components. Excessive tightening torques lead to parts wearing out more quickly. Parts that are too loose may cause leakage.

- Observe the specified tightening torques (see 'Tightening torques' in Annex).
-

ⓘ NOTICE

Risk of regulator damage due to the use of unsuitable lubricants.

- Only use lubricants approved by SAMSON (see 'Lubricants' in Annex).
-

i Note

The regulator was checked by SAMSON before it left the factory.

- Certain test results certified by SAMSON lose their validity when the regulator is opened. Such testing includes seat leakage and leak tests.
 - The product warranty becomes void if service or repair work not described in these instructions is performed without prior agreement by SAMSON's After-sales Service.
 - Only use original spare parts by SAMSON, which comply with the original specifications.
-

i Note

Do not damage or shorten the capillary tube. Roll up any capillary tube that is not used. The smallest permissible bending radius is 50 mm.

💡 Tip

SAMSON's After-sales Service can support you in drawing up an inspection and test plan for your plant.

Type 1 with Type 2111 Valve

Flanged valve body EN-GJS-400-18-LT,
EN-GJL-250

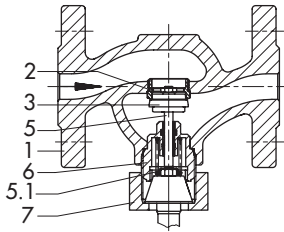

Type 4/Type 4u with Type 2422 Valve

Flanged valve body EN-GJL-250,
EN-GJS-400-18-LT, 1.0619, 1.4408

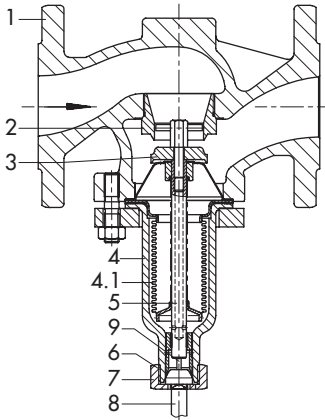

Flanged valve body 1.0619, 1.4408

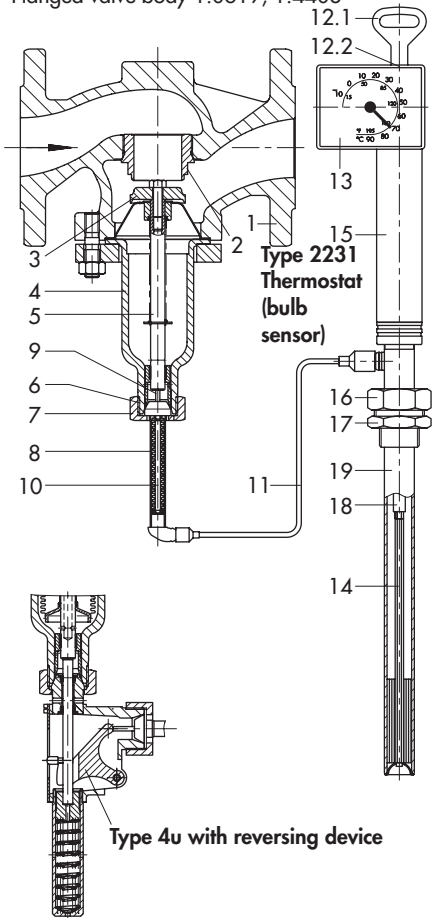

Fig. 9-1: Functional diagram

Servicing

| | | | | | |
|-----|-------------------|------|---|------|-------------------------------|
| 1 | Valve body | 6 | Threaded connection for operating element | 12.2 | Set point adjuster |
| 2 | Seat | 7 | Coupling nut | 13 | Set point dial |
| 3 | Plug | 8 | Operating element | 14 | Spindle |
| 4 | Bottom section | 9 | Pin of operating element | 15 | Excess temperature protection |
| 4.1 | Balancing bellows | 10 | Operating bellows | 16 | Coupling nut |
| 5 | Plug stem | 11 | Capillary tube | 17 | Double nipple |
| 5.1 | Spring | 12.1 | Set point adjustment key | 18 | Piston |
| | | | | 19 | Thermostat with bulb sensor |

9.1 Preparing the valve for service work

1. Lay out the necessary material and tools to have them ready for the service work.
2. Put the regulator out of operation (see the 'Decommissioning' section).



Tip

We recommend removing the regulator from the pipeline before performing any service work (see the 'Removing the regulator from the pipeline' section).

The following service work can be performed after preparation is completed:

- Replace the control thermostat (see section 9.4).
- Replace the seat and plug (see section 9.5)

9.2 Installing the regulator after service work

- Put the regulator back into operation (see the 'Start-up' section). Make sure the requirements and conditions for start-up or putting the valve back into operation are met.

9.3 Service work

- Before performing any service work, preparations must be made to the regulator (see section 9.1).
- After all service work is completed, check the regulator before putting it back into operation (see the 'Testing the regulator' section).

9.4 Replacing the control thermostat

- See Fig. 9-1

⚠ WARNING

Risk of personal injury due to pressurized components and process medium being discharged.

Incorrect opening of pressure equipment or mounting parts may lead to the process medium escaping to the atmosphere.

- *Do not loosen the control thermostat while the valve is pressurized.*
 - *Do not start up the regulator until all parts have been mounted.*
-

Removing the control thermostat

1. Put the regulator out of operation (see the 'Decommissioning' section).
2. Unscrew the coupling nut (11) of the operating element (8) from the valve.
3. If applicable, unscrew the coupling nut (16) from the control thermostat and pull out the control thermostat.
4. If the thermostat still works, adjust the highest possible temperature set point, causing the pin (9) of operating element to detach itself from the plug stem of the valve. Then remove the control thermostat.

Mounting the control thermostat

1. Place the operating element (8) on the valve and fasten tight the coupling nut (11). Observe the specified tightening torques (see 'Tightening torques' in Annex).
2. If applicable, push the control thermostat into the thermowell and tighten the coupling nut (16).
3. Put the regulator back into operation (see the 'Start-up' section).

9.5 Replacing the seat and plug

To replace seat and plug, contact SAMSON's After-sales Service.

Further information is available in Annex ('After-sales service').

9.6 Ordering spare parts and operating supplies

Contact your nearest SAMSON subsidiary or SAMSON's After-sales Service for information on spare parts, lubricants and tools.

Spare parts

See Annex for details on spare parts.

Lubricant

Contact SAMSON's After-sales Service for more information on lubricants.

Tools

Contact SAMSON's After-sales Service for more information on tools.

10 Decommissioning

The work described in this section is only to be performed by personnel appropriately qualified to carry out such tasks.

⚠ DANGER

Risk of bursting due to incorrect opening of pressurized equipment or components.

Regulators and pipelines are pressure equipment that may burst when handled incorrectly. Flying projectile fragments or the release of process medium under pressure can cause serious injury or even death.

Before working on the regulator:

- Depressurize all plant sections concerned and the regulator.
- Drain the process medium from all the plant sections concerned as well as the valve.

⚠ WARNING

Risk of burn injuries due to hot or cold components and pipeline.

Regulator components and the pipeline may become very hot or cold. Risk of burn injuries.

- Allow components and pipelines to cool down or warm up to the ambient temperature.
- Wear protective clothing and safety gloves.

⚠ WARNING

Risk of personal injury due to pressurized components and process medium being discharged.

Incorrect opening of pressure equipment or mounting parts may lead to the process medium escaping to the atmosphere.

- Do not loosen the control thermostat while the valve is pressurized.
- Do not start up the regulator until all parts have been mounted.

⚠ WARNING

Risk of hearing loss or deafness due to loud noise.

Noise emission (e.g. cavitation) may occur during operation caused by the process medium and the operating conditions.

- Wear hearing protection when working near the regulator. Follow the instructions given by the plant operator.

⚠ WARNING

Risk of personal injury due to residual process medium in the regulator.

While working on the regulator, residual process medium can escape and, depending on its properties, may lead to personal injury, e.g. (chemical) burns.

- Wear protective clothing, safety gloves and eye protection.

Decommissioning

To decommission the regulator for service work or disassembly, proceed as follows:

1. Close the shut-off valve (1) on the upstream side of the regulator.
2. Close the shut-off valve (6) on the downstream side of the regulator.
3. Depressurize the plant.
4. Completely drain the pipelines and valve.
5. If necessary, allow the pipeline and regulator components to cool down or warm up to the ambient temperature.

11 Removal

The work described in this section is only to be performed by personnel appropriately qualified to carry out such tasks.

⚠ WARNING

Risk of burn injuries due to hot or cold components and pipeline.

Regulator components and the pipeline may become very hot or cold. Risk of burn injuries.

- *Allow components and pipelines to cool down or warm up to the ambient temperature.*
- *Wear protective clothing and safety gloves.*

⚠ WARNING

Risk of personal injury due to residual process medium in the regulator.

While working on the regulator, residual process medium can escape and, depending on its properties, may lead to personal injury, e.g. (chemical) burns.

- *Wear protective clothing, safety gloves and eye protection.*

Before removing the valve, make sure the following conditions are met:

- The regulator is put out of operation (see the 'Decommissioning' section).

11.1 Removing the control thermostat

1. Pull the sensor out of the thermowell. In cases where a thermowell is not used, unscrew the screw gland and pull out the sensor.
2. Unscrew the control thermostat from the valve (width across flats 36).

11.2 Removing the regulator from the pipeline

1. Support the regulator to hold it in place when separated from the pipeline (see the 'Shipment and on-site transport' section).
2. Unbolt the flanged joint.
3. Remove the regulator from the pipeline (see the 'Shipment and on-site transport' section).

12 Repairs

If the regulator does not function properly according to how it was originally sized or does not function at all, it is defective and must be repaired or exchanged.

! NOTICE

Risk of regulator damage due to incorrect service or repair work.

→ Contact SAMSON's After-sales Service for service and repair work.

12.1 Returning devices to SAMSON

Defective devices can be returned to SAMSON for repair.

Proceed as follows to return devices:

1. Exceptions apply concerning some special device models
 - ▶ www.samsongroup.com > Service & Support > After-sales Service.
2. Send an e-mail ▶ retouren@samsongroup.com to register the return shipment including the following information:

- Type
- Material no.
- Item numbers of accessories
- Original order
- Completed Declaration on Contamination, which can be downloaded from our website at
 - ▶ www.samsongroup.com > Service & Support > After-sales Service.

After checking your registration, we will send you a return merchandise authorization (RMA).

3. Attach the RMA (together with the Declaration on Decontamination) to the outside of your shipment so that the documents are clearly visible.
4. Send the shipment to the address given on the RMA.

i Note

Further information on returned devices and how they are handled can be found at

▶ www.samsongroup.com > Service & Support > After-sales Service.

13 Disposal



We are registered with the German national register for waste electric equipment (stiftung ear) as a producer of electrical and electronic equipment, WEEE reg. no.: DE 62194439

- Observe local, national and international refuse regulations.
- Do not dispose of components, lubricants and hazardous substances together with your other household waste.

i Note

We can provide you with a recycling passport according to PAS 1049 on request. Simply e-mail us at offersaleservice@samsongroup.com giving details of your company address.

Tip

On request, we can appoint a service provider to dismantle and recycle the product.

14 Certificates

The EU declarations of conformity are included on the next pages:

- EU declaration of conformity in compliance with Pressure Equipment Directive 2014/68/EU on page 14-2.
- EU declaration of conformity in compliance with Machinery Directive 2006/42/EC for Type 1, Type 4 and Type 4u Regulators on page 14-4.
- Declaration of incorporation in compliance with Machinery Directive 2006/42/EC for Type 2111 and Type 2422 Valves on page 14-7.
- Declaration of incorporation in compliance with Machinery Directive 2006/42/EC for Type 2231 to Type 2234 Control Thermostats on page 14-9.



EU-KONFORMITÄTSERKLÄRUNG EU DECLARATION OF CONFORMITY

Modul H/Module H, Nr./No. / N° CE-0062-PED-H-SAM 001-16-DEU-rev-A

SAMSON erklärt in alleiniger Verantwortung für folgende Produkte:/For the following products, SAMSON hereby declares under its sole responsibility:

Ventile für Druck-, Differenzdruck-, Temperatur- und Volumenstromregler/Valves for pressure, temperature, flowregulators and differential pressure regulators

Typ 2336, 2373, 2375, 44-1B, 44-2, 44-3, 44-4, 44-6B, 44-9, 45-1, 45-2, 45-3, 45-4, 45-6, (Erz.-Nr. 2720), 45-9, 47-4, 2488, 2489, (2730), 2405, 2406, 2421 (2811), 2412 (2812), 2417 (2817), 2422 (2814), 2423 (2823), 2423E (2823)

die Konformität mit nachfolgender Anforderung/the conformity with the following requirement

Richtlinie des Europäischen Parlaments und des Rates zur Harmonisierung der Rechtsvorschriften der Mitgliedstaaten über die Bereitstellung von Druckgeräten auf dem Markt. 2014/68/EU vom 15.05.2014

Directive of the European Parliament and of the Council on the harmonization of the laws of the Member States relating to the making available on the market of pressure equipment (see also Articles 41 and 48). 2014/68/EU of 15 May 2014

Angewandtes Konformitätsbewertungsverfahren für Fluide nach Art. 4(1)(c.i) erster Gedankenstrich. Modul siehe Tabelle durch
Conformity assessment procedure applied for fluids according to Article 4(1)(c.i), first indent See table for module Bureau Veritas S. A. (0062)

| Nenndruck Pressure rating | DN NPS | 15 ½ | 20 ¾ | 25 1 | 32 1¼ | 40 1½ | 50 2 | 65 - | 80 3 | 100 4 | 125 - | 150 6 | 200 8 | 250 10 | 300 12 | 400 16 |
|------------------------------|-----------|-----------------------------|---------|---------------------|----------|----------|---------|---------|---------|----------|----------|----------|----------|-----------|-----------|-----------|
| PN 16 | | ohne/without ⁽¹⁾ | | A ⁽²⁾⁽³⁾ | | | | - | - | - | - | - | - | - | - | - |
| PN 25 | | ohne/without ⁽¹⁾ | | A ⁽²⁾⁽³⁾ | | | | | | H | | | | | | |
| PN 40 | | ohne/without ⁽¹⁾ | | A ⁽²⁾⁽³⁾ | | | | | | H | | | | | | |
| PN 100 und PN 160 | | ohne/without ⁽¹⁾ | | A ⁽²⁾⁽³⁾ | | | | | H | | | | | - | - | - |
| Class 150 | | ohne/without ⁽¹⁾ | | A ⁽²⁾⁽³⁾ | | | | | | H | | | | | | |
| Class 300 | | ohne/without ⁽¹⁾ | | A ⁽²⁾⁽³⁾ | | | | | | H | | | | | | |
| Class 600 und Class 900 | | ohne/without ⁽¹⁾ | | A ⁽²⁾⁽³⁾ | | | | | H | | | | | - | - | - |

- Das auf dem Stellgerät aufgebrachte CE-Zeichen hat keine Gültigkeit im Sinne der Druckgeräterichtlinie.
The CE marking affixed to the control valve is not valid in the sense of the Pressure Equipment Directive.
- Das auf dem Stellgerät aufgebrachte CE-Zeichen gilt ohne Bezeichnung der benannten Stelle (Kenn-Nr. 0062).
The CE marking affixed to the control valve is valid without specifying the notified body (ID number 0062).
- Die Identifikationsnummer 0062 von Bureau Veritas S.A. gilt nicht für Modul A.
The identification number 0062 of Bureau Veritas S.A. is not valid for Modul A.

Geräte, denen laut Tabelle das Konformitätsbewertungsverfahren Modul H zugrunde liegt, beziehen sich auf die „Zulassungsbescheinigung eines Qualitätssicherungssystems“ ausgestellt durch die benannte Stelle.
Devices whose conformity has been assessed based on Module H refer to the certificate of approval for the quality management system issued by the notified body.

Dem Entwurf zu Grunde gelegt sind Verfahren aus:/The design is based on the methods of:
DIN EN 12516-2, DIN EN 12516-3 bzw./or ASME B16.1, ASME B16.24, ASME B16.34, ASME B16.42
Das Qualitätssicherungssystem des Herstellers wird von folgender benannter Stelle überwacht:
The manufacturer's quality management system is monitored by the following notified body:

**Bureau Veritas S.A. Nr./No. 0062, Newtime, 52 Boulevard du Parc, Ile de la Jatte, 92200 Neuilly sur Seine, France
Hersteller:/Manufacturer: SAMSON AG, Weismüllerstraße 3, 60314 Frankfurt am Main, Germany**

Frankfurt am Main, 08. Februar 2017/08 February 2017

i.v. Klaus Hirschchen
Klaus Hirschchen
Zentralabteilungsleiter / Head of Central Department
Entwicklung Ventile und Antriebe / R&D, Valves and Actuators

Dr. Michael Heß
Dr. Michael Heß
Zentralabteilungsleiter / Head of Central Department
Product Management & Technical Sales



EU-KONFORMITÄTSERKLÄRUNG EU DECLARATION OF CONFORMITY

Modul H/Module H, Nr./No. / N° CE-0062-PED-H-SAM 001-20-DEU

SAMSON erklärt in alleiniger Verantwortung für folgende Produkte:/For the following products, SAMSON hereby declares under its sole responsibility:

Ventile für Temperaturregler/Valves for temperature regulators

Typ/Type 2111, 2121, 2431, 2432, 2435, 2436, 2437 (Erz.-Nr./Model No. 2710), 2433, 2118 (2713), 2119 (2803), 2121 (2811), 2114 (2814)

die Konformität mit nachfolgender Anforderung/the conformity with the following requirement.

Richtlinie des Europäischen Parlaments und des Rates zur Harmonisierung der Rechtsvorschriften der Mitgliedstaaten über die Bereitstellung von Druckgeräten auf dem Markt. 2014/68/EU vom 15.05.2014

Directive of the European Parliament and of the Council on the harmonization of the laws of the Member States relating of the making available on the market of pressure equipment. 2014/68/EU of 15 May 2014

Angewandtes Konformitätsbewertungsverfahren für Fluide nach Art. 4(1)(c.ii) und (c.i) zweiter Gedankenstrich.

Modul siehe Tabelle

durch certified by Bureau Veritas Services SAS. (0052)

Conformity assessment procedure applied for fluids according to Article 4(1)(c.ii) and (c.i), second indent

See table for module

| Druck Pressure rating | DN NPS | 15 ½ | 20 ¾ | 25 1 | 32 1¼ | 40 1½ | 50 2 | 65 | 80 3 | 100 4 | 125 | 150 6 | 200 8 | 250 10 | |
|--------------------------|-----------|------------------|---------|---------|----------|----------|---------|----------|---------|----------|-----|----------|----------|-----------|--|
| PN 16 | | ohne/without (1) | | | | | | A (2)(3) | | | H | | | | |
| PN 25 | | ohne/without (1) | | | | | | A (2)(3) | | | H | | | | |
| PN 40 | | ohne/without (1) | | | | | | A (2)(3) | | | H | | | | |
| Class 150 | | ohne/without (1) | | | | | | A (2)(3) | | | H | | | | |
| Class 300 | | ohne/without (1) | | | | | | A (2)(3) | | | H | | | | |

(1) Das auf dem Stellgerät aufgebrachte CE-Zeichen hat keine Gültigkeit im Sinne der Druckgeräterichtlinie.
The CE marking affixed to the control valve is not valid in the sense of the Pressure Equipment Directive.

(2) Das auf dem Stellgerät aufgebrachte CE-Zeichen gilt ohne Bezeichnung der benannten Stelle (Kenn-Nr. 0062).
The CE marking affixed to the control valve is valid without specifying the notified body (ID number 0062).

(3) Die Identifikationsnummer 0062 von Bureau Veritas Services SAS gilt nicht für Modul A.
The identification number 0062 of Bureau Veritas Services SAS is not valid for module A.

Geräte, denen laut Tabelle das Konformitätsbewertungsverfahren Modul H zugrunde liegt, beziehen sich auf die „Zulassungsbescheinigung eines Qualitätssicherungssystems“ ausgestellt durch die Notifizierte Stelle.

Devices whose conformity has been assessed based on Module H refer to the certificate of approval for the quality management system issued by the notified body.

Dem Entwurf zu Grunde gelegt sind Verfahren aus /The design is based on the procedures specified in the following standards:
DIN EN 12516-2, DIN EN 12516-3 bzw. /or ASME B16.1, ASME B16.24, ASME B16.34, ASME B16.42

Das Qualitätssicherungssystem des Herstellers wird von folgender benannter Stelle überwacht

The manufacturer's quality management system is monitored by the following notified body:

Bureau Veritas Services SAS, 8 Cours du Triangle, 92800 PUTEAUX – LA DEFENSE, France
Hersteller/Manufacturer: SAMSON AG, Weismüllerstraße 3, 60314 Frankfurt am Main, Germany

Frankfurt am Main, 11. Mai 2020/11. May 2020

Thorsten Muth
Senior Director
Sales and After-sales

Peter Scheermesser
Director Central Department
Product maintenance, contract development and ETO for valves and actuators

EU DECLARATION OF CONFORMITY TRANSLATION



Declaration of Conformity of Final Machinery

in accordance with Annex II, section 1.A. of the Directive 2006/42/EC

For the following product:

Type 1 Temperature Regulators consisting of Type 2111 Valve and Type 2231, 2232, 2233, 2234 or 2235 Control Thermostat

We hereby declare that the machinery mentioned above complies with all applicable requirements stipulated in Machinery Directive 2006/42/EC.

For product descriptions of the valve and control thermostat, refer to:

- Type 1 Temperature Regulator: Mounting and Operating Instructions EB 2111/2121/2123

Referenced technical standards and/or specifications:

- VCI, VDMA, VGB: "Leitfaden Maschinenrichtlinie (2006/42/EG) – Bedeutung für Armaturen, Mai 2018" [German only]
- VCI, VDMA, VGB: "Zusatzdokument zum Leitfaden Maschinenrichtlinie (2006/42/EG) – Bedeutung für Armaturen vom Mai 2018" [German only], based on DIN EN ISO 12100:2011-03

Comment:

Information on residual risks of the machinery can be found in the mounting and operating instructions of the valve and control thermostat as well as in the referenced documents listed in the mounting and operating instructions.

Persons authorized to compile the technical file:

SAMSON AG, Weismüllerstraße 3, 60314 Frankfurt am Main, Germany
Frankfurt am Main, 5 May 2021

Peter Arzbach
Director
Product Management

Peter Scheermesser
Director
Product Life Cycle Management and
ETO Development for Valves and Actuators

Revision no. 00

EU DECLARATION OF CONFORMITY TRANSLATION



Declaration of Conformity of Final Machinery

in accordance with Annex II, section 1.A. of the Directive 2006/42/EC

For the following product:

Type 4 Temperature Regulators consisting of Type 2422 Valve and Type 2231, 2232, 2233, 2234 or 2235 Control Thermostat

We hereby declare that the machinery mentioned above complies with all applicable requirements stipulated in Machinery Directive 2006/42/EC.

For product descriptions of the valve and control thermostat, refer to:

- Type 4 Temperature Regulator: Mounting and Operating Instructions EB 2111/2121/2123

Referenced technical standards and/or specifications:

- VCI, VDMA, VGB: "Leitfaden Maschinenrichtlinie (2006/42/EG) – Bedeutung für Armaturen, Mai 2018" [German only]
- VCI, VDMA, VGB: "Zusatzdokument zum Leitfaden Maschinenrichtlinie (2006/42/EG) – Bedeutung für Armaturen vom Mai 2018" [German only], based on DIN EN ISO 12100:2011-03

Comment:

Information on residual risks of the machinery can be found in the mounting and operating instructions of the valve and control thermostat as well as in the referenced documents listed in the mounting and operating instructions.

Persons authorized to compile the technical file:

SAMSON AG, Weismüllerstraße 3, 60314 Frankfurt am Main, Germany
Frankfurt am Main, 5 May 2021

Peter Arzbach
Director
Product Management

Peter Scheermesser
Director
Product Life Cycle Management and
ETO Development for Valves and Actuators

Revision no. 00

EU DECLARATION OF CONFORMITY

TRANSLATION



Declaration of Conformity of Final Machinery

in accordance with Annex II, section 1.A. of the Directive 2006/42/EC

For the following product:

Type 4u Temperature Regulators consisting of Type 2422 Valve with reversing device and Type 2231, 2232, 2233, 2234 or 2235 Control Thermostat

We hereby declare that the machinery mentioned above complies with all applicable requirements stipulated in Machinery Directive 2006/42/EC.

For product descriptions of the valve and control thermostat, refer to:

- Type 4u Temperature Regulator: Mounting and Operating Instructions EB 2111/2121/2123

Referenced technical standards and/or specifications:

- VCI, VDMA, VGB: "Leitfaden Maschinenrichtlinie (2006/42/EG) – Bedeutung für Armaturen, Mai 2018" [German only]
- VCI, VDMA, VGB: "Zusatzdokument zum Leitfaden Maschinenrichtlinie (2006/42/EG) – Bedeutung für Armaturen vom Mai 2018" [German only], based on DIN EN ISO 12100:2011-03

Comment:

Information on residual risks of the machinery can be found in the mounting and operating instructions of the valve and control thermostat as well as in the referenced documents listed in the mounting and operating instructions.

Persons authorized to compile the technical file:

SAMSON AG, Weismüllerstraße 3, 60314 Frankfurt am Main, Germany
Frankfurt am Main, 5 May 2021

Peter Arzbach
Director
Product Management

Peter Scheermesser
Director
Product Life Cycle Management and ETO
Development for Valves and Actuators

Revision no. 00



Einbauerklärung nach Maschinenrichtlinie 2006/42/EG

Für folgendes Produkt:
Ventil Typ 2111

Wir, die SAMSON AG, erklären, dass das Ventil Typ 2111 eine unvollständige Maschine im Sinne der Maschinenrichtlinie 2006/42/EG ist und die sicherheitstechnischen Anforderungen nach Anhang I Artikel 1.1.2, 1.1.3, 1.1.5, 1.3.2, 1.3.4 und 1.3.7 der Richtlinie eingehalten werden. Die speziellen Unterlagen nach Anhang VII Teil B wurden erstellt.

Die Inbetriebnahme der von uns gelieferten Erzeugnisse darf nur erfolgen, wenn vorher festgestellt wurde, dass die Maschinen oder Anlagen, in die die Produkte eingebaut werden sollen, den Bestimmungen der EG-Maschinenrichtlinie 2006/42/EG entsprechen.

Der Anwender ist verpflichtet, das Erzeugnis den anerkannten Regeln der Technik und der Einbau- und Bedienungsanleitung entsprechend einzubauen und Gefährdungen, die am Stellventil vom Durchflussmedium und Betriebsdruck sowie vom Stelldruck und von beweglichen Teilen ausgehen können, durch geeignete Maßnahmen zu verhindern.

Die zulässigen Einsatzgrenzen und Montagehinweise der Geräte ergeben sich aus der Einbau- und Bedienungsanleitung und stehen im Internet unter www.samsongroup.com in elektronischer Form zur Verfügung.

Produktbeschreibung siehe:

- Temperaturregler Typ 1: Einbau- und Bedienungsanleitung EB 2111/2121/2123
- Sicherheitstemperaturbegrenzer (STB) mit Sicherheitsthermostat Typ 2212: Einbau- und Bedienungsanleitung EB 2046
- Sicherheitstemperaturwächter (STW) Typ 2213: Einbau- und Bedienungsanleitung EB 2043

Folgende technischen Normen und/oder Spezifikationen wurden angewandt:

- VCI/VDMA/VGB – Leitfadens Maschinenrichtlinie (2006/42/EG) – Bedeutung für Armaturen, Mai 2018
- VCI/VDMA/VGB – Zusatzdokument zum „Leitfadens Maschinenrichtlinie (2006/42/EG) – Bedeutung für Armaturen vom Mai 2018“, Stand Mai 2018 in Anlehnung an DIN EN ISO 12100:2011-03

Bemerkungen:

- Restgefahren siehe Angaben in der Einbau- und Bedienungsanleitung
- Weiterhin sind die in den Einbau- und Bedienungsanleitungen aufgeführten mitgeltenden Dokumente zu beachten.

Für die Zusammenstellung der technischen Unterlagen ist bevollmächtigt:

SAMSON AG, Weismüllerstraße 3, 60314 Frankfurt am Main, Germany
Frankfurt am Main, 10. November 2021



i.V. Stephan Giesen
Zentralabteilungsleiter
Produktmanagement

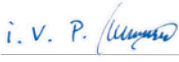

i.V. Peter Scheermesser
Zentralabteilungsleiter
Produktpflege, Auftragsentwicklung und
ETO Ventile und Antriebe

Revision 00

DECLARATION OF INCORPORATION TRANSLATION



Declaration of Incorporation in Compliance with Machinery Directive 2006/42/EC

For the following product: **Type 2422 Valve**

We certify that the Type 2422 Valve is partly completed machinery as defined in the Machinery Directive 2006/42/EC and that the safety requirements stipulated in Annex I, 1.1.2, 1.1.3, 1.1.5, 1.3.2, 1.3.4 and 1.3.7 are observed. The relevant technical documentation described in Annex VII, part B has been compiled.

Products we supply must not be put into service until the final machinery into which it is to be incorporated has been declared in conformity with the provisions of the Machinery Directive 2006/42/EC.

Operators are obliged to install the products observing the accepted industry codes and practices (good engineering practice) as well as the mounting and operating instructions. Operators must take appropriate precautions to prevent hazards that could be caused by the process medium and operating pressure in the valve as well as by the signal pressure and moving parts.

The permissible limits of application and mounting instructions for the products are specified in the associated mounting and operating instructions; the documents are available in electronic form on the Internet at www.samsongroup.com.

For product descriptions refer to:

- Types 1, 4 and 4u Temperature Regulators: Mounting and Operating Instructions EB 2111/2121/2123
- Type 2404-2 Excess Pressure Valve with pilot valve: Mounting and Operating Instructions EB 2540
- Type 2422/2424 Pressure Reducing Valve: Mounting and Operating Instructions EB 2547
- Type 2422/2425 Excess Pressure Valve: Mounting and Operating Instructions EB 2549
- Type 2333 Pressure Reducing Valve with pilot valve: Mounting and Operating Instructions EB 2552-1
- Type 2335 Excess Pressure Valve with pilot valve: Mounting and Operating Instructions EB 2552-2
- Type 2334 Universal Regulator with pilot valve: Mounting and Operating Instructions EB 3210
- Type 42-20, Type 42-25 Differential Pressure Regulators: Mounting and Operating Instructions EB 3007
- Type 42-24, Type 42-28 Differential Pressure Regulators: Mounting and Operating Instructions EB 3003
- Safety Temperature Limiters (STL) with Type 2212 Safety Thermostat:
Mounting and Operating Instructions EB 2046
- Type 2213 Safety Temperature Monitor (STM): Mounting and Operating Instructions EB 2043

Referenced technical standards and/or specifications:

- VCI, VDMA, VGB: "Leitfaden Maschinenrichtlinie (2006/42/EG) – Bedeutung für Armaturen, Mai 2018" [German only]
- VCI, VDMA, VGB: "Zusatzdokument zum Leitfaden Maschinenrichtlinie (2006/42/EG) – Bedeutung für Armaturen vom Mai 2018" [German only], based on DIN EN ISO 12100:2011-03

Comments:

- See mounting and operating instructions for residual hazards.
- Also observe the referenced documents listed in the mounting and operating instructions.

Persons authorized to compile the technical file:

SAMSON AG, Weismüllerstraße 3, 60314 Frankfurt am Main, Germany
Frankfurt am Main, 10 November 2021

Stephan Giesen
Director
Product Management

Peter Scheermesser
Director
Product Life Cycle Management and ETO
Development for Valves and Actuators

Revision no. 00

DECLARATION OF INCORPORATION TRANSLATION



Declaration of Incorporation in Compliance with Machinery Directive 2006/42/EC

For the following product:
Type 2231 Thermostat

We certify that the Type 2231 Thermostat is partly completed machine as defined in the Machinery Directive 2006/42/EC and that the safety requirements stipulated in Annex I, 1.1.2, 1.1.3, 1.1.5, 1.3.2, 1.3.4 and 1.3.7 are observed. The relevant technical documentation described in Annex VII, part B has been compiled.

Products we supply must not be put into service until the final machinery into which it is to be incorporated has been declared in conformity with the provisions of the Machinery Directive 2006/42/EC.

Operators are obliged to install the products observing the accepted industry codes and practices (good engineering practice) as well as the mounting and operating instructions. Operators must take appropriate precautions to prevent hazards that could be caused by the process medium and operating pressure in the valve as well as by the signal pressure and moving parts.

The permissible limits of application and mounting instructions for the products are specified in the associated data sheets as well as the mounting and operating instructions; the documents are available in electronic form on the Internet at www.samsongroup.com.

For product descriptions refer to:

- Type 2231 Thermostat: Mounting and Operating Instructions EB 2231

Referenced technical standards and/or specifications:

- VCI, VDMA, VGB: "Leitfaden Maschinenrichtlinie (2006/42/EG) – Bedeutung für Armaturen, Mai 2018" [German only]
- VCI, VDMA, VGB: "Zusatzdokument zum Leitfaden Maschinenrichtlinie (2006/42/EG) – Bedeutung für Armaturen vom Mai 2018" [German only], based on DIN EN ISO 12100:2011-03

Comments:

- See mounting and operating instructions for residual hazards.
- Also observe the referenced documents listed in the mounting and operating instructions.

Persons authorized to compile the technical file:

SAMSON AG, Weismüllerstraße 3, 60314 Frankfurt am Main, Germany
Frankfurt am Main, 20 September 2021

i.v.

Stephan Giesen
Director
Product Management

i. v. F.

Peter Scheermesser
Director
Product Life Cycle Management and ETO Development for
Valves and Actuators

Revision no. 00

DECLARATION OF INCORPORATION TRANSLATION



Declaration of Incorporation in Compliance with Machinery Directive 2006/42/EC

For the following product:
Type 2232 Thermostat

We certify that the Type 2232 Thermostat is partly completed machine as defined in the Machinery Directive 2006/42/EC and that the safety requirements stipulated in Annex I, 1.1.2, 1.1.3, 1.1.5, 1.3.2, 1.3.4 and 1.3.7 are observed. The relevant technical documentation described in Annex VII, part B has been compiled.

Products we supply must not be put into service until the final machinery into which it is to be incorporated has been declared in conformity with the provisions of the Machinery Directive 2006/42/EC.

Operators are obliged to install the products observing the accepted industry codes and practices (good engineering practice) as well as the mounting and operating instructions. Operators must take appropriate precautions to prevent hazards that could be caused by the process medium and operating pressure in the valve as well as by the signal pressure and moving parts.

The permissible limits of application and mounting instructions for the products are specified in the associated data sheets as well as the mounting and operating instructions; the documents are available in electronic form on the Internet at www.samsongroup.com.

For product descriptions refer to:

- Type 2232 Thermostat: Mounting and Operating Instructions EB 2231

Referenced technical standards and/or specifications:

- VCI, VDMA, VGB: "Leitfaden Maschinenrichtlinie (2006/42/EG) – Bedeutung für Armaturen, Mai 2018" [German only]
- VCI, VDMA, VGB: "Zusatzdokument zum Leitfaden Maschinenrichtlinie (2006/42/EG) – Bedeutung für Armaturen vom Mai 2018" [German only], based on DIN EN ISO 12100:2011-03

Comments:

- See mounting and operating instructions for residual hazards.
- Also observe the referenced documents listed in the mounting and operating instructions.

Persons authorized to compile the technical file:

SAMSON AG, Weismüllerstraße 3, 60314 Frankfurt am Main, Germany
Frankfurt am Main, 20 September 2021

Stephan Giesen
Director
Product Management

Peter Scheermesser
Director
Product Life Cycle Management and ETO Development for
Valves and Actuators

Revision no. 00

DECLARATION OF INCORPORATION TRANSLATION



Declaration of Incorporation in Compliance with Machinery Directive 2006/42/EC

For the following product:
Type 2233 Thermostat

We certify that the Type 2233 Thermostat is partly completed machine as defined in the Machinery Directive 2006/42/EC and that the safety requirements stipulated in Annex I, 1.1.2, 1.1.3, 1.1.5, 1.3.2, 1.3.4 and 1.3.7 are observed. The relevant technical documentation described in Annex VII, part B has been compiled.

Products we supply must not be put into service until the final machinery into which it is to be incorporated has been declared in conformity with the provisions of the Machinery Directive 2006/42/EC.

Operators are obliged to install the products observing the accepted industry codes and practices (good engineering practice) as well as the mounting and operating instructions. Operators must take appropriate precautions to prevent hazards that could be caused by the process medium and operating pressure in the valve as well as by the signal pressure and moving parts.

The permissible limits of application and mounting instructions for the products are specified in the associated data sheets as well as the mounting and operating instructions; the documents are available in electronic form on the Internet at www.samsongroup.com.

For product descriptions refer to:

- Type 2233 Thermostat: Mounting and Operating Instructions EB 2231

Referenced technical standards and/or specifications:

- VCI, VDMA, VGB: "Leitfaden Maschinenrichtlinie (2006/42/EG) – Bedeutung für Armaturen, Mai 2018" [German only]
- VCI, VDMA, VGB: "Zusatzdokument zum Leitfaden Maschinenrichtlinie (2006/42/EG) – Bedeutung für Armaturen vom Mai 2018" [German only], based on DIN EN ISO 12100:2011-03

Comments:

- See mounting and operating instructions for residual hazards.
- Also observe the referenced documents listed in the mounting and operating instructions.

Persons authorized to compile the technical file:

SAMSON AG, Weismüllerstraße 3, 60314 Frankfurt am Main, Germany
Frankfurt am Main, 20 September 2021

i.v.

Stephan Giesen
Director
Product Management

i.v.

Peter Scheermesser
Director
Product Life Cycle Management and ETO Development for
Valves and Actuators

Revision no. 00

DECLARATION OF INCORPORATION TRANSLATION



Declaration of Incorporation in Compliance with Machinery Directive 2006/42/EC

For the following product:
Type 2234 Thermostat

We certify that the Type 2234 Thermostat is partly completed machine as defined in the Machinery Directive 2006/42/EC and that the safety requirements stipulated in Annex I, 1.1.2, 1.1.3, 1.1.5, 1.3.2, 1.3.4 and 1.3.7 are observed. The relevant technical documentation described in Annex VII, part B has been compiled.

Products we supply must not be put into service until the final machinery into which it is to be incorporated has been declared in conformity with the provisions of the Machinery Directive 2006/42/EC.

Operators are obliged to install the products observing the accepted industry codes and practices (good engineering practice) as well as the mounting and operating instructions. Operators must take appropriate precautions to prevent hazards that could be caused by the process medium and operating pressure in the valve as well as by the signal pressure and moving parts.

The permissible limits of application and mounting instructions for the products are specified in the associated data sheets as well as the mounting and operating instructions; the documents are available in electronic form on the Internet at www.samsongroup.com.

For product descriptions refer to:

- Type 2234 Thermostat: Mounting and Operating Instructions EB 2231

Referenced technical standards and/or specifications:

- VCI, VDMA, VGB: "Leitfaden Maschinenrichtlinie (2006/42/EG) – Bedeutung für Armaturen, Mai 2018" [German only]
- VCI, VDMA, VGB: "Zusatzdokument zum Leitfaden Maschinenrichtlinie (2006/42/EG) – Bedeutung für Armaturen vom Mai 2018" [German only], based on DIN EN ISO 12100:2011-03

Comments:

- See mounting and operating instructions for residual hazards.
- Also observe the referenced documents listed in the mounting and operating instructions.

Persons authorized to compile the technical file:

SAMSON AG, Weismüllerstraße 3, 60314 Frankfurt am Main, Germany
Frankfurt am Main, 20 September 2021

i.v. S.Y.
Stephan Giesen
Director
Product Management

i.v. P. Scheermesser
Peter Scheermesser
Director
Product Life Cycle Management and ETO Development for
Valves and Actuators

Revision no. 00

DECLARATION OF INCORPORATION TRANSLATION



Declaration of Incorporation in Compliance with Machinery Directive 2006/42/EC

For the following product:
Type 2235 Thermostat

We certify that the Type 2235 Thermostat is partly completed machine as defined in the Machinery Directive 2006/42/EC and that the safety requirements stipulated in Annex I, 1.1.2, 1.1.3, 1.1.5, 1.3.2, 1.3.4 and 1.3.7 are observed. The relevant technical documentation described in Annex VII, part B has been compiled.

Products we supply must not be put into service until the final machinery into which it is to be incorporated has been declared in conformity with the provisions of the Machinery Directive 2006/42/EC.

Operators are obliged to install the products observing the accepted industry codes and practices (good engineering practice) as well as the mounting and operating instructions. Operators must take appropriate precautions to prevent hazards that could be caused by the process medium and operating pressure in the valve as well as by the signal pressure and moving parts.

The permissible limits of application and mounting instructions for the products are specified in the associated data sheets as well as the mounting and operating instructions; the documents are available in electronic form on the Internet at www.samsongroup.com.

For product descriptions refer to:

- Type 2235 Thermostat: Mounting and Operating Instructions EB 2231

Referenced technical standards and/or specifications:

- VCI, VDMA, VGB: "Leitfaden Maschinenrichtlinie (2006/42/EG) – Bedeutung für Armaturen, Mai 2018" [German only]
- VCI, VDMA, VGB: "Zusatzdokument zum Leitfaden Maschinenrichtlinie (2006/42/EG) – Bedeutung für Armaturen vom Mai 2018" [German only], based on DIN EN ISO 12100:2011-03

Comments:

- See mounting and operating instructions for residual hazards.
- Also observe the referenced documents listed in the mounting and operating instructions.

Persons authorized to compile the technical file:

SAMSON AG, Weismüllerstraße 3, 60314 Frankfurt am Main, Germany
Frankfurt am Main, 20 September 2021

i.v. [Signature]

Stephan Giesen
Director
Product Management

i.v. [Signature]

Peter Scheermesser
Director
Product Life Cycle Management and ETO Development for
Valves and Actuators

Revision no. 00

15 Annex

15.1 Tightening torques

Table 15-1: *Tightening torque*

| Part | Width across flats | Valve size/ actuator area | Tightening torque in Nm |
|------------------|--------------------|------------------------------|-------------------------|
| Coupling nut (7) | SW 36 | All | 25 |

15.2 Lubricant

SAMSON's After-sales Service can support you concerning lubricants and sealants approved by SAMSON.

15.3 Tools

SAMSON's After-sales Service can support you concerning tools approved by SAMSON.

15.4 Accessories

Double adapter, manual adjuster, extension piece and separating piece can be supplied as required.

These accessories are listed under 'Accessories' in the 'Design and principle of operation' section and in ► T 2595.

15.5 Spare parts

15.5.1 Valve

Legend for Fig. 15-1 to Fig. 15-3

| | | | |
|----|----------------|-----|--------------------|
| 1 | Body | 36 | Nipple |
| 2 | Bottom section | 97 | Flange |
| 4 | Seat | 109 | Nameplate |
| 5 | Plug | 500 | Bellows |
| 12 | Washer | 502 | Balancing screw |
| 13 | Bolt | 506 | Connecting nipple |
| 14 | Nut | 507 | Guide cap |
| 18 | Guide bushing | 525 | Compression spring |
| 19 | Guide tube | 558 | Washer |
| 30 | Washer | 596 | Retaining washer |

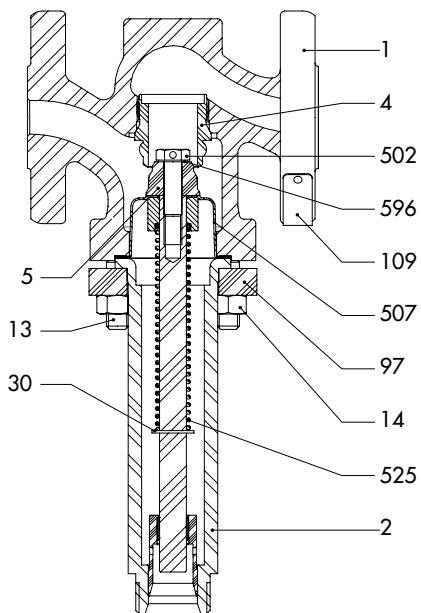
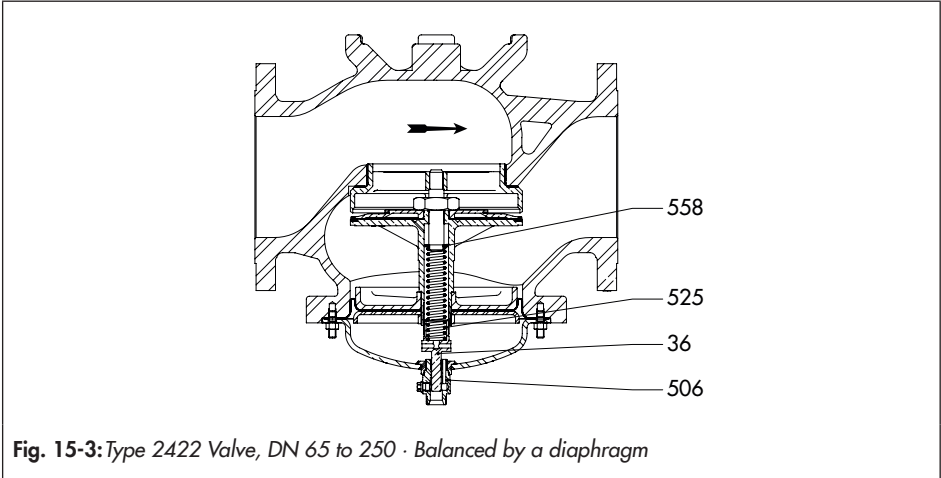
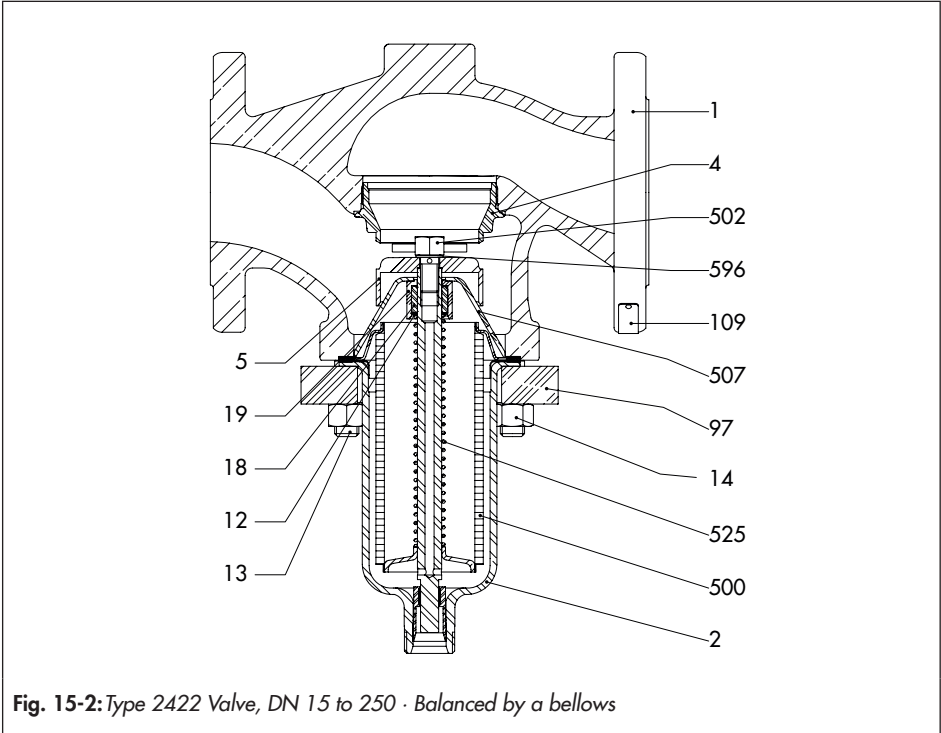

Fig. 15-1: Type 2422 Valve, DN 15 to 50 · Unbalanced



15.5.2 Control thermostat

There are no spare parts available for the Type 2231 to 2234 Control Thermostats.

15.6 After-sales service

Contact SAMSON's After-sales Service for support concerning service or repair work or when malfunctions or defects arise.

E-mail address

You can reach our after-sales service at aftersalesservice@samsongroup.com.

Addresses of SAMSON AG and its subsidiaries

The addresses of SAMSON, its subsidiaries, representatives and service facilities worldwide can be found on our website ( www.samsongroup.com) or in all SAMSON product catalogs.

Required specifications

Please submit the following details:

- Device type and valve size
- Valve not balanced, balanced by a bellows or diaphragm
- Model number or material number
- Upstream and downstream pressure
- Temperature and process medium
- Min. and max. flow rate in m³/h
- Is a strainer installed?
- Installation drawing showing the exact location of the regulator and all the additionally installed components (shut-off valves, pressure gauge etc.)

EB 2111/2121/2123 EN



SAMSON AKTIENGESELLSCHAFT
Weismüllerstraße 3 · 60314 Frankfurt am Main, Germany
Phone: +49 69 4009-0 · Fax: +49 69 4009-1507
samson@samsongroup.com · www.samsongroup.com