



Type 01b · PFA-lined Globe Control Valve

Single-seated globe valve · DIN and ANSI version



Application

PFA-lined control valve for corrosive media, especially suitable for high requirements in chemical plants and other industries.

- Valve size DN 15 to 150 ¹⁾ /NPS ½ to 6 ¹⁾
- Pressure rating PN 10 and 16/Class 150
- Temperatures -10 to +200 °C

The control valve consists of a single-seated globe valve with PFA lining and either a pneumatic actuator or hand-operated actuator. The valve is designed according to the modular-assembly principle and has the following features:

- Valve body of EN-JS 1049/A395 as standard, with 3-5 mm thick PFA lining
- Exchangeable PTFE/TFM seat and PTFE plug
- Stem sealed by a PTFE bellows and a backup, spring-loaded PTFE V-ring packing
- Test connection for monitoring
- Exchangeable actuator
- Additional equipment and mounting parts available according to IEC 60534 and NAMUR recommendations
- Face-to-face dimensions for DIN version according to DIN EN 558, Series 1
- Face-to-face dimensions for ANSI version according to DIN EN 558, Series 37

¹⁾ DN 15/NPS ½ and DN 150/NPS 6 available on request

Versions

The Type 01b Globe Valve is available optionally in the following versions:

- With SAMSON pneumatic actuator
- With SAMSON hand-operated actuator
- With actuators of other manufacturers on request

Special versions

- Lining made of conductive PFA
- Lining for -40 °C
- Flange with groove
- SSB bellows for special applications
- We recommend our Type 1a Control Valves to meet special requirements

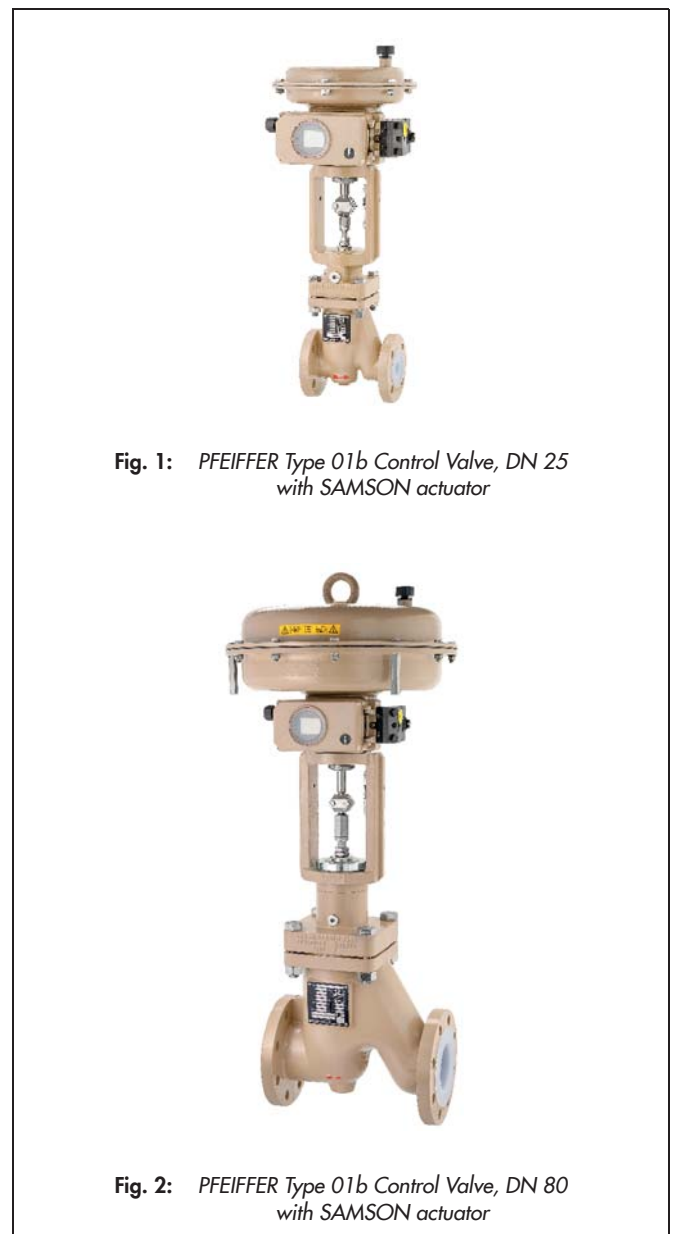

Fig. 1: PFEIFFER Type 01b Control Valve, DN 25 with SAMSON actuator

Fig. 2: PFEIFFER Type 01b Control Valve, DN 80 with SAMSON actuator

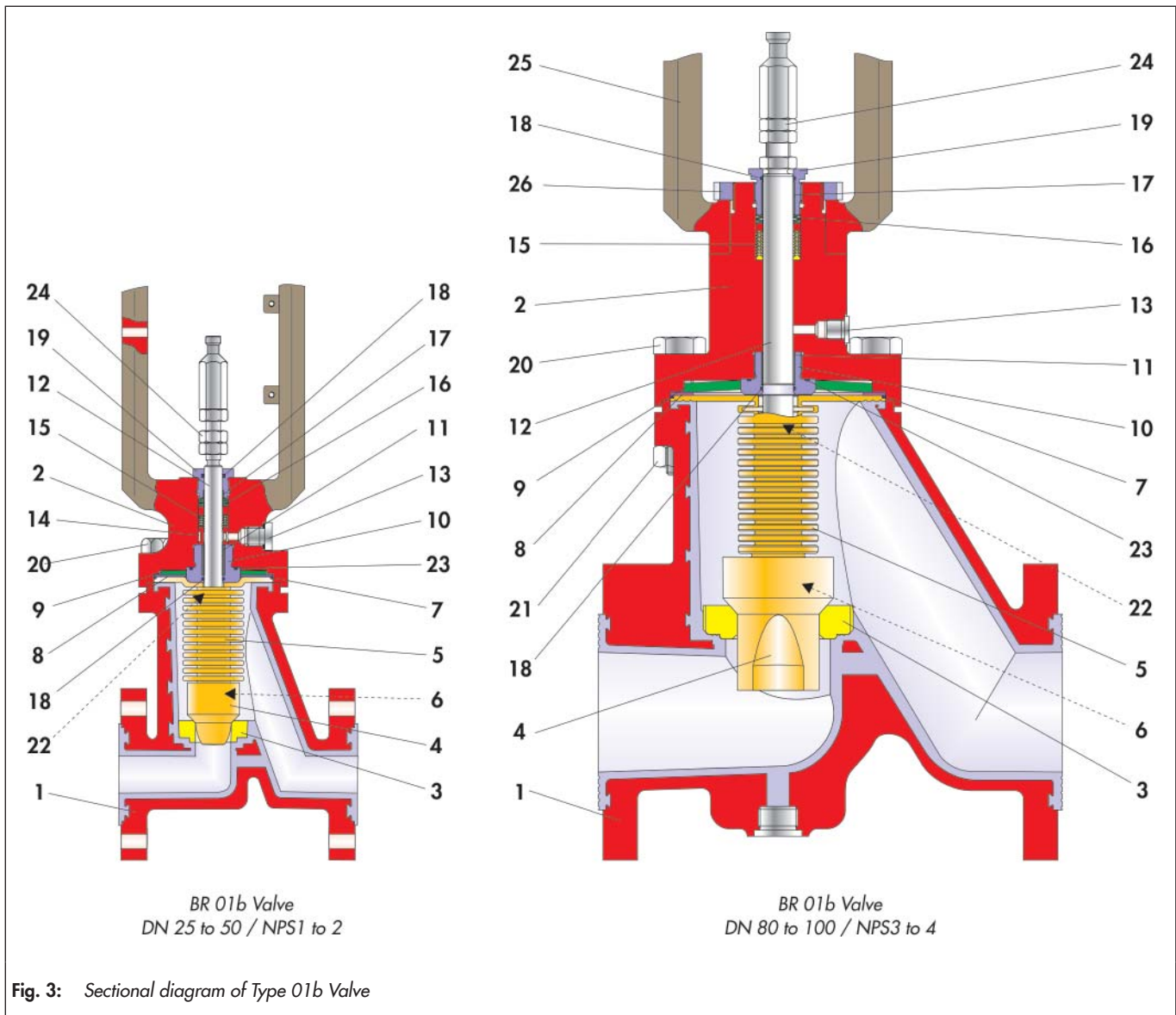

Fig. 3: Sectional diagram of Type 01b Valve

Table 1: Parts list

Item	Description
1	Valve body
2	Bonnet flange
3	Seat
4	Plug
5	Bellows
6	Cord
7	O-ring
8	Thrust washer
9	Spring washer
10	Guide bushing
11	Bearing bushing
12	Stem
13	Screw plug (test connection)

Item	Description
14	Distance bushing
15	V-ring packing
16	Set of spring washers
17	Bearing bushing
18	O-ring
19	Packing
20	Bolt
21	Nut
22	Retainer ring
23	O-ring
24	Nut
25	Yoke
26	Slotted nut

Principle of operation

The process medium flows through the Type 01b Control Valve in the flow-to-open direction. The valve plug position determines the cross-sectional area of flow between the plug (4) and seat (3).

The plug is connected over the stem (12) to the actuator stem.

The PTFE bellows (5) seals the area between the valve body (1) and stem (12).

The PTFE V-ring packing (15) is used as a backup stem sealing.

A test connection port (13) allows the bellows to be monitored for leakage, e.g. by connecting a suction line or inert gas line.

The PTFE seat (3) is screwed into the valve body (1) using a suitable thread for plastic.

i Note

- In the event that cavitation may occur, we recommend the use of a guided plug for differential pressures above 3 bar or differential pressure ratio $p_2 < \Delta p$.
- Lined control valves are not suitable for operation with cavitation.
- We recommend using our Type 01a Valve in applications with cavitation noise or flow velocities above 25 m/s in the vena contracta.

i Note

The maximum permissible outlet velocity is 3 m/s. Contact us if higher velocities occur.

i Note

Before using the valve in hazardous areas, check whether this is possible according to ATEX 2014/34/EU. Refer to the Operating Instructions ► BA01a.

Fail-safe position

Depending on how the pneumatic actuator is mounted onto the valve, the valve has two fail-safe positions which become effective when the air pressure in the actuator is relieved or when the supply air fails:

- **Control valve with fail-close actuator:**
Upon air failure, the valve is closed. The valve opens when the signal pressure increases, acting against the force of the springs.
- **Control valve with fail-open actuator:**
Upon air failure, the valve is opened. The valve closes when the signal pressure increases, acting against the force of the springs.

Additional equipment and mounting parts

The following accessories are optionally available for the valve separately or in combinations:

- Positioner
- Limit switches
- Solenoid valves
- Supply air pressure regulator/filter
- Pressure gauge mounting blocks
- Pneumatic volume booster

Other accessories possible according to specifications on request.

Pressure-temperature diagram

The range of application is determined by the pressure-temperature diagram. Process data and medium can affect the values in the diagram.

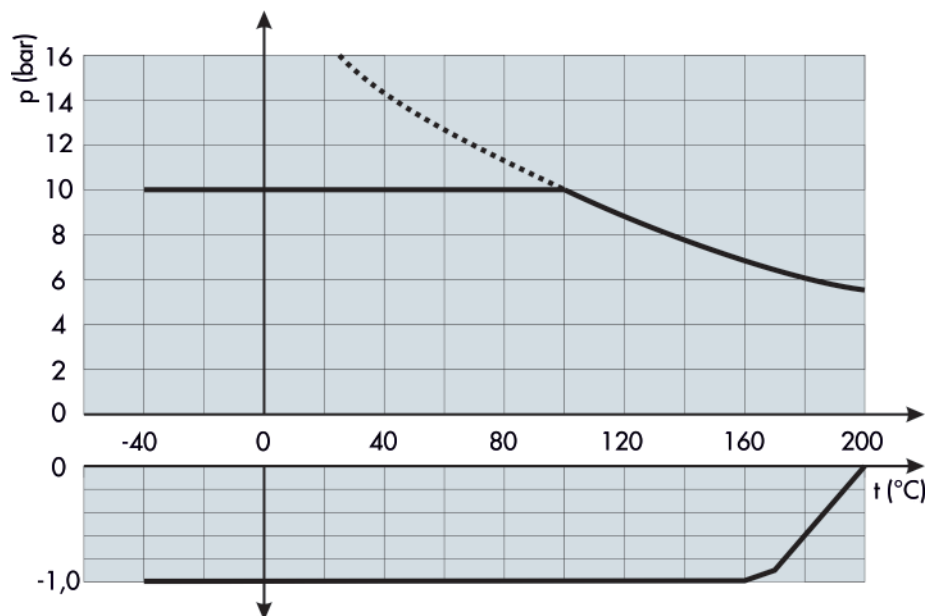

Fig. 4: Pressure-temperature diagram

Table 2: General technical data

Valve size	DN 15 to 150	NPS ½ to 6
Pressure rating	PN 10/16	PN 10/16 (flanges according to ANSI Class 150)
Temperature range	See pressure-temperature diagram	
Characteristic	Equal percentage/linear	
Leakage range	Leakage rate A acc. to DIN EN 12266-1, test P12 (leakage rate 1 BO according to DIN 3230 Part 3)	
Rangeability	20:1 (up to K_{VS} 0.1) · 50:1 (K_{VS} 0.25 and higher) · 30:1 (DN 80 and larger)	
End connections	DIN EN 1092-2, Form B	ANSI Class 150

Table 3: Material

Body	EN-JS 1049/A 395
Lining	Thick-walled PFA lining
Bonnet flange	EN-JS 1049/A395
Plug and seat	PTFE ¹⁾ , optionally special material
Bellows	PTFE, optionally special material
Packing	PTFE V-ring packing loaded by spring washers
Stem	Corrosion-resistant steel 1.4571
Coating	Two-component polyurethane coat, grey beige (RAL 1019)

¹⁾ Control insert made of tantalum or other metals for 2 mm seat diameter

Dimensions and weights

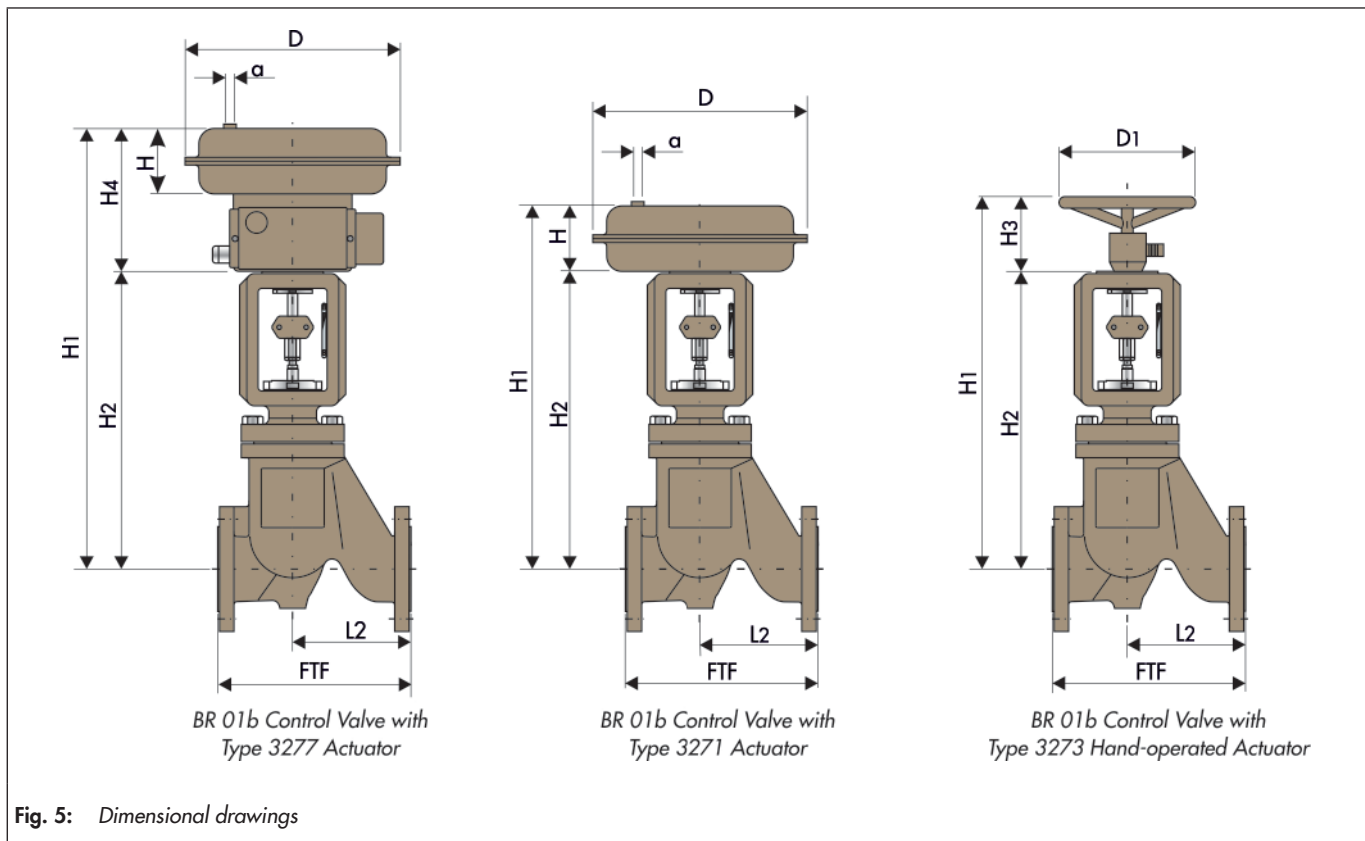

Table 4: Dimensions mm and weights in kg

Valve size		(DN 15)	DN 25	DN 40	DN 50	DN 80	DN 100	(DN 150)
FTF	Basic series 1		160	200	230	310	350	
L2	Basic series 1		96	121	146	190	239	
H1	SAMSON Type 3271	H2 + H						
	SAMSON Type 3277	H2 + H4						
	SAMSON Type 3273	H2 + H3						
H2	Actuator 175v2 to 750v2 cm ²		347	369	383.5	544	582	
Weight of valve in kg			11.5	18	21.5	40	57	
Actuator	175v2 cm ²		•	•	•			
	240 cm ²		•	•	•			
	350 cm ²			•	•			
	700 cm ²					•	•	
	750v2 cm ²				•	•	•	
D1			180	180	180	250	250	
H3			92	92	92	92	92	
Weight of Type 3273 in kg			2	2	2	2.5	2.5	

Valve size		(NPS ½)	NPS 1	NPS 1½	NPS 2	NPS 3	NPS 4	(NPS 6)
FTF	Basic series 37		184	222	254	298	352	
L2	Basic series 37		96	121	146	190	239	
H1	SAMSON Type 3271	H2 + H						
	SAMSON Type 3277	H2 + H4						
	SAMSON Type 3273	H2 + H3						
H2	Actuator 175v2 to 750v2 cm ²		347	369	383.5	544	582	
Weight of valve in kg			11.5	18	21.5	40	57	
Actuator	175v2 cm ²		•	•	•			
	240 cm ²		•	•	•			
	350 cm ²			•	•			
	700 cm ²					•	•	
	750v2 cm ²				•	•	•	
D1			180	180	180	250	250	
H3			92	92	92	92	92	
Weight of Type 3273 in kg			2	2	2	2.5	2.5	

Actuator in cm ²	175v2	240	350	700	750v2
Diaphragm D	215	240	280	390	394
Hight H	78	65	85	135	171
Hight H4	179	166	183	239	272
Signal pressure connection a	G ¼		G ⅜		
Weight of Type 3271	6	5	8	22	36
Weight of Type 3277	10	9	12	26	40

Table 5: Permissible differential pressures Δp

The permissible differential pressures specified only apply to soft-seated valves.

Signal pressure range				Fail-close								Fail-open ¹⁾								
				0.2 to 1.0	0.4 to 2.0	0.5 to 2.5	0.6 to 3.0	1.1 to 2.4	1.3 to 2.9	1.4 to 2.3	1.9 to 3.1	0.2 to 1.0								
Supply pressure				Required supply pressure								Max. supply pressure								
				1.4	2.4	2.9	3.4	2.8	3.3	2.7	3.5	1.2	1.4	1.6	2.0	2.7				
DN	NPS	Seat ϕ in mm	Actuator in cm ²	Δp when $p_2 = 0$																
25	1	2	175v2	16 ²⁾	16 ²⁾									16 ²⁾						
			240	16 ²⁾											16 ²⁾					
		6	175v2	16												16				
			240	16												16				
		13	175v2	3	16											3	16			
			240		16												16			
		24	175v2		4	7	10			16						4	10			
			240		9		16									9	16			
			350	4	16											4	16			
		40	1½	30	175v2		1	3	5		16						5	13		
					240		5		11							5	11			
					350		10		16							10	16			
50	2	40	175v2			1	2		11								7	16		
			240		3		6								6					
			350		5		11								5	11				
			750v2 ³⁾	5 ³⁾	16 ³⁾										5	16				
80	3	65	700		4		8							4	7					
			750v2			6				16					4	8	16			
100	4	95	700				2								2	6	12			
			750v2				3			10	16				3	6	13			

Table 5a: Valves with SAMSON fail-close actuator
Valve closed with signal pressure 0 bar

Table 5b: Valves with SAMSON fail-open actuator
Valve closed with required signal pressure

¹⁾ We recommended using an actuator with travel stop. In all other cases, the supply air must be limited.

²⁾ Actuator with travel stop

³⁾ At travel 30 mm

Table 6: z values depending on K_{VS} coefficient, valve size and seat diameter

Valve size		(DN 15)/DN 25			DN 25	DN 40	DN 50	DN 80	DN 100	(DN 150)
		(NPS ½)/NPS 1			NPS 1	NPS 1½	NPS 2	NPS 3	NPS 4	(NPS 6)
Seat ø in mm		2 ¹⁾	6	13	24	30	40	65	95	150
K_{VS}	C_V	Acoustical valve coefficient z								
0.005	0.006	0.85								
0.01	0.01									
0.025	0.03									
0.05	0.06									
0.1	0.12	0.85	0.65							
0.25	0.29		0.65							
0.63	0.74			0.65						
1.0	1.17									
1.6	1.9			0.6						
2.5	2.9									
4	4.7				0.55	0.55				
6.3	7.4				0.45	0.5	0.5			
10	12				0.4	0.45	0.45			
16	19					0.4	0.4	0.45		
25	29						0.35	0.4	0.4	
28	33						0.35			
30	35						0.35			
40	47							0.35	0.35	
63	74							0.3	0.3	
80	94							0.25	0.25	
100	117								0.25	
125	146								0.2	
150	175									0.2
260	304									0.2
300	351									0.2

¹⁾ Linear characteristic is only possible for a 2 mm seat diameter

Table 7: K_{VS} coefficient, travel and seat diameter of parabolic plugs and V-port plugs

Valve size		(DN 15)/DN 25			DN 25	DN 40	DN 50	DN 80	DN 100	(DN 150)
		(NPS ½)/NPS 1			NPS 1	NPS 1½	NPS 2	NPS 3	NPS 4	(NPS 6)
Seat ø in mm		2	6	13	24	30	40	65	95	150
Travel in mm		10	15				30			60
K_{VS}	C_V									
0.005	0.006	P ¹⁾								
0.01	0.01									
0.025	0.029									
0.05	0.06									
0.1	0.12	P ¹⁾	P							
0.25	0.29		P							
0.4 ²⁾	0.47 ²⁾		P							
0.63	0.74			T						
1.0	1.17			T						
1.6	1.9			T						
2.5	2.9									
4	4.7				T	T				
6.3	7.4				T	T	T			
10	12				T	T	T			
16	19					T	T	T		
25	29						T	T	T	
28	33						T			
30	35						T ¹⁾			
35	41							T		
40	47							T	T	
63	74							T	T	
80	94							T	T	
100	117								T	
125	146								T	
150	175									
260	304									
300	351									

P = Parabolic plug, T = V-port plug

¹⁾ Linear only

²⁾ Use parabolic plugs only up to K_{VS} 0.4. Otherwise, contact PFEIFFER.

Terms for control valve sizing

According to IEC 60534-2-1:

$$FL = 0.95 \quad xT = 0.75$$

Correction terms

For gases and vapors: $\Delta LG = 0$

For liquids: $\Delta LF = 0$

Selection and sizing of the control valve

1. Calculate the appropriate K_{VS} according to IEC 60534-2-1.
2. Select valve size and K_{VS} according to Table 6.
3. Determine the differential pressure and select the suitable actuator from Table 5a and 5b.
4. Check the application against the pressure-temperature diagram.
5. Select additional equipment.

Ordering text:

BR 01b Control Valve

Valve size:

Pressure rating:

Flow coefficient: K_{VS}

Characteristic: equal percentage/linear

Body: EN-JS 1049/white PFA

Flange design:

Special design:

Actuator: SAMSON Type cm²

Signal pressure range: bar

Fail-safe position:

Limit switch (brand name):

Solenoid valve (brand name):

Positioner (brand name):

Others:

Associated data sheets

- SAMSON pneumatic actuator

▶ T 8310-x

i Note

All relevant details regarding the version ordered, which deviate from the specified version in this technical description data, can be taken, if required, from the corresponding order confirmation.
