

Self-operated Pressure Regulators Series 44



Type 44-1 B · Pressure Reducing Valves

Type 44-6 B · Excess Pressure Valve

Application

Set points from **0.2 to 20 bar** with valves in sizes **G ½, G ¾** and **G 1** as well as **DN 15, 25, 40** and **50** · Nominal pressure **PN 25** · Suitable for air up to **150 °C**, nitrogen up to **200 °C**, other gases up to **80 °C** and liquids up to **150 °C**

Type 44-1 B Pressure Reducing Valve:

The valve closes when the downstream pressure increases.

Type 44-6 B Excess Pressure Valve:

The valve opens when the upstream pressure increases.

The regulators consist of a valve and an actuator with an operating bellows and a set point adjuster.

Special features

- Low-maintenance P-regulators requiring no auxiliary energy
- Wide set point range and easy set point adjustment
- Spring-loaded, single-seated valve without pressure balancing or balanced by a metal bellows
- Stainless steel operating bellows as operating element
- Compact design with particularly low overall height
- Any mounting position possible
- Valve body made of red brass, spheroidal graphite iron or stainless steel
- Meets TA-Luft requirements concerning fugitive emissions based on VDI 2440

Versions

Pressure regulators with actuators for set point ranges from 0.2 to 20 bar · Valve bodies with screwed ends in red brass or spheroidal graphite iron with **G ½, G ¾** or **G 1** female thread · Versions with flanged body in DN 15 and DN 25 made of stainless steel · Versions with flanged body in DN 15, 25, 40 and 50 made of spheroidal graphite iron

Type 44-1 B Pressure Reducing Valve (Figs. 1, 3) · Regulator with valve in PN 25 for liquids up to 150 °C, air up to 150 °C, nitrogen up to 200 °C and gases up to 80 °C

Type 44-6 B Excess Pressure Valve (Fig. 2) · Regulator with valve in PN 25 for liquids up to 150 °C, air up to 150 °C, nitrogen up to 200 °C, other gases up to 80 °C and steam up to 200 °C

Special versions

With oil-resistant internal parts · Spheroidal graphite iron body with wetted parts made of non-ferrous metal · Version free of PTFE · Version for flammable gases available on request Regulator prepared for connection of a pressure gauge or external control line (**G ⅛** thread) · Stainless steel body available with FFKM internal parts · Version made of FDA-compliant materials · With electric set point adjustment (up to G 1 or DN 25) for set points up to 10 bar · With pneumatic set point adjuster (up to G 1 or DN 25) · Version functioning as differential pressure regulator (up to G 1 or DN 25) · Version for steam (Type 44-6 B)

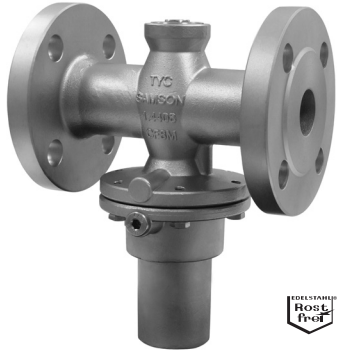
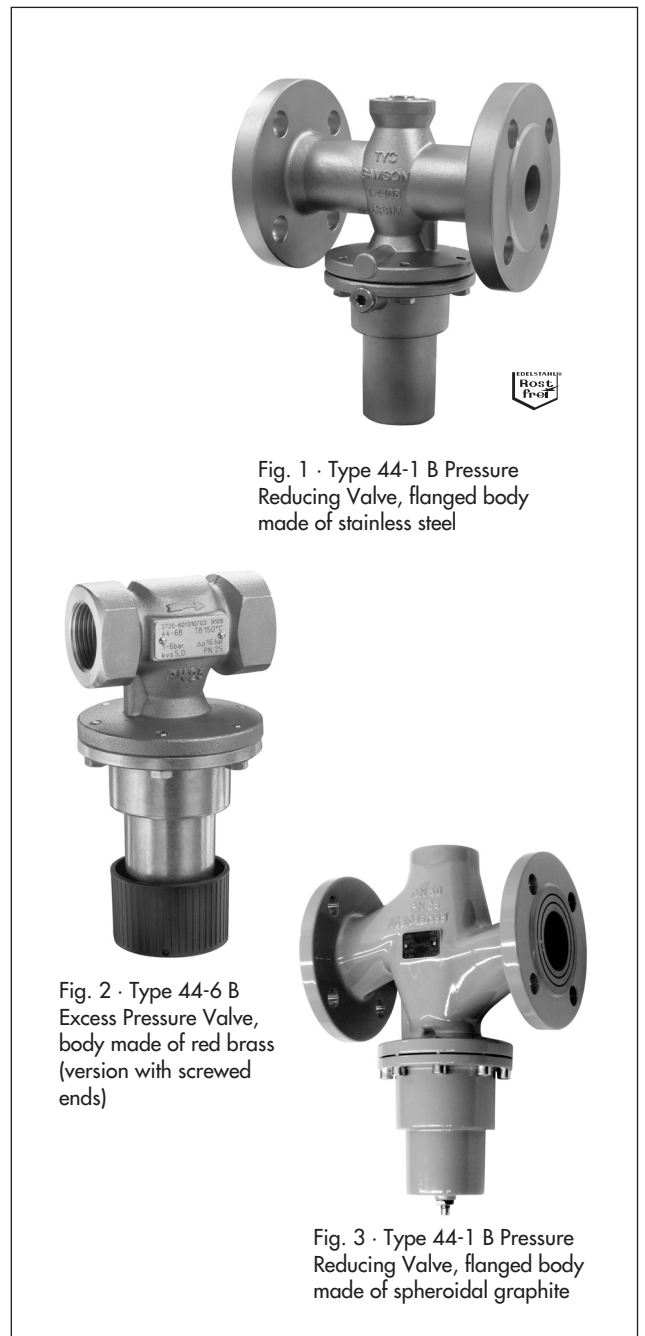

Fig. 1 · Type 44-1 B Pressure Reducing Valve, flanged body made of stainless steel



Fig. 2 · Type 44-6 B Excess Pressure Valve, body made of red brass (version with screwed ends)



Fig. 3 · Type 44-1 B Pressure Reducing Valve, flanged body made of spheroidal graphite

Principle of operation

The medium flows through the valve in the direction indicated by the arrow on the body. The position of the valve plug determines the flow rate across the area released between the valve plug (2) and seat (3).

The Type 44-1 B Pressure Reducing Valve is open when relieved of pressure. The valve closes when the downstream pressure (p_2) exceeds the adjusted set point.

The Type 44-6 B Excess Pressure Valve is closed when relieved of pressure. The valve opens when the upstream pressure (p_1) exceeds the adjusted set point.

In both versions, the pressure to be maintained at a constant value is transmitted through a bore (4) in the valve body (1) to the operating bellows (5) where it is converted into a positioning force. This force is used to move the valve plug depending on the spring constant of the set point spring(s) (7) and the value adjusted on the set point adjuster (8) or set point screw (9). This applies to a set point range from 8 to 20 bar as well as to the versions with bodies made of stainless steel and spheroidal graphite iron (DN 40 and 50).

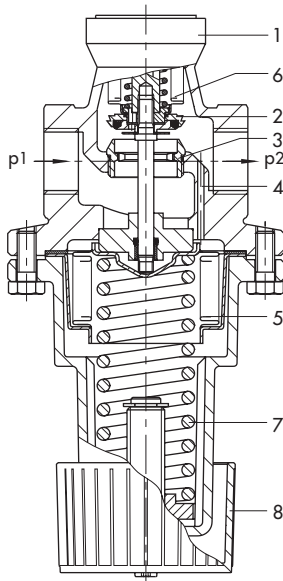

Type 44-1 B Pressure Reducing Valve · Body with screwed ends

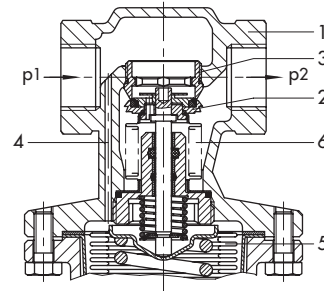

Type 44-6 B Excess Pressure Valve · Body with screwed ends

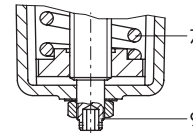

Version of stainless steel or spheroidal graphite iron (DN 40 and 50 only) and 8 to 20 bar set point range
Set point adjusted at a hexagon socket screw

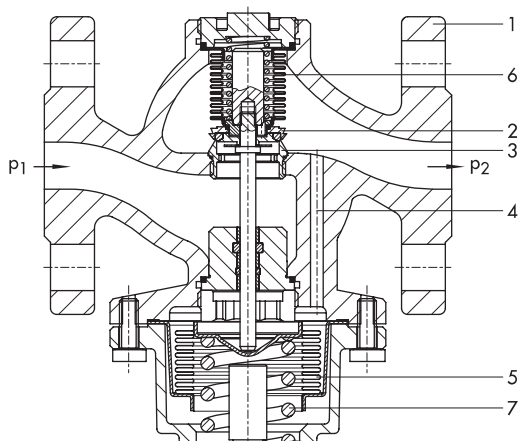

Types 44-0 B, 44-1 B Pressure Reducing Valves
Flanged body (spheroidal graphite iron)

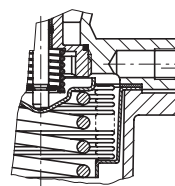

Special version
G $\frac{1}{8}$ thread for connection of a pressure gauge or an external control line

Special version of Type 44-1 B or Type 44-6 B
Regulators prepared for connection of a pressure gauge or external control line

- | | |
|-----------------------------|--|
| 1 Valve body | 6 Balancing bellows |
| 2 Plug | 7 Set point spring |
| 3 Seat | 8 Set point adjuster (manual adjuster) |
| 4 Bore for control pressure | 9 Set point screw |
| 5 Operating bellows | |

Fig. 4 · Functional diagrams

Table 1 · Technical data · All pressures in bar (gauge)

Regulator		Pressure Reducing Valves 44-1 B	Excess Pressure Valve 44-6 B
Type			
Connection	Stainless steel/red brass body	G ½, G ¾, G 1 female thread	
	Stainless steel body	Flanged body DN 15 and 25	
	Spheroidal graphite iron body	Flanged body DN 15, 25 and 50	
Nominal pressure		PN 25	
Max. permissible temperature	Liquids	150 °C	
	Non-flammable gases	80 °C	
	Steam	–	200 °C
	Nitrogen	200 °C	
Max. permissible differential pressure Δp	G ½ to G 1 · DN 15 and 25	16 bar	
	DN 40 and 50	8 bar	
Set point range, continuously adjustable		0.2 to 2 bar · 1 to 4 bar · 2 to 6 bar · 4 to 10 bar · 8 to 20 bar ¹⁾	
Leakage rate		≤ 0.05 % of K_{VS}	
Max. permissible ambient temperature		60 °C	

¹⁾ Set point range not for DN 40 and 50

Table 2 · K_{VS} coefficients and z values
Body with screwed ends

Connection		G ½	G ¾	G 1
K_{VS}	Standard version	3.2 ¹⁾	4 ¹⁾	5 ¹⁾
	Special version (without pressure balancing)	0.25 · 0.4 · 1 ¹⁾ · 2.5		
z values		0.60		0.55

Flanged body

Nominal size		DN 15	DN 25	DN 40	DN 50
K_{VS}	Standard version	3.2 ¹⁾	5 ¹⁾	16	20
	Special version (without pressure balancing)	0.25 ²⁾ · 0.4 · 1 ¹⁾ · 2.5		8 ²⁾	
z values		0.60	0.55	0.4	

¹⁾ Regulators with stainless steel bodies and FFKM soft seal also available as special version

²⁾ Only with Type 44-1 B with metal seal

Table 3 · Materials

Body	Red brass CC491K/CC499K	Spheroidal graphite iron EN-JS1049	Stainless steel 1.4408
Seat	Stainless steel 1.4305		1.4404
Plug	Type 44-1 B · Type 44-6 B Brass resistant to dezincification with soft seal ¹⁾		1.4404 with metal or soft seal ²⁾
	Type 44-6 B (steam) Brass resistant to dezincification with PTFE soft seal or metal seal ¹⁾		1.4404 with FKM/PTFE soft seal or metal seal
Balancing bellows	1.4571		1.4571
Plug spring	1.4310		1.4310
Set point spring	1.7104 (55SiCr6)		1.4310
Operating bellows	1.4571		1.4571
Spring housing	EN AC-44300-DF (die-cast aluminum)		1.4408
Set point adjuster	Manual adjuster made of PETP with 30 % glass fiber ³⁾		Hexagon socket screw made of 1.4571

¹⁾ Regulators with spheroidal graphite iron bodies and internal parts made of non-ferrous metal: plug of 1.4404 with metal or soft seal

²⁾ EPDM, FFKM or PTFE

³⁾ 8 to 20 bar set point range: hexagon socket screw made of 1.4571

Table 4 · Versions and K_{VS} coefficients

Version with	Plug · Soft-seated				Plug · Metal-seated
	EPDM/FKM	Stainless steel with FFKM	PTFE		
K_{VS} coefficients Type 44-1 B	0.25 · 1 · 2.5 · 3.2 · 4 5 · 16 · 20	1 · 3.2 · 4 · 5	–		0.25 · 0.4 · 1 · 8
Type 44-6 B	1 · 2.5 · 3.2 · 4 · 5 · 16 · 20	1 · 3.2 · 4 · 5	3.2 · 4 · 5		0.4 · 1

Table 5 · Sealing materials and max. medium temperatures

Plug sealing	Medium · max. temperature
EPDM	Water · Up to 150 °C Oil-free air · Up to 80 °C Nitrogen · Up to 80 °C
FKM	Oil · Up to 150 °C Air · Up to 150 °C Nitrogen · Up to 200 °C
PTFE ¹⁾	Steam · Up to 200 °C
FFKM	Liquids · Up to 150 °C

¹⁾ Only with Type 44-1 B

Installation

The following applies:

- The direction of flow must match the arrow on the valve body.
- The regulators can be installed in any desired mounting position.

For details refer to EB 2626-1 EN and EB 2626-2 EN.

Flow rate diagram for water

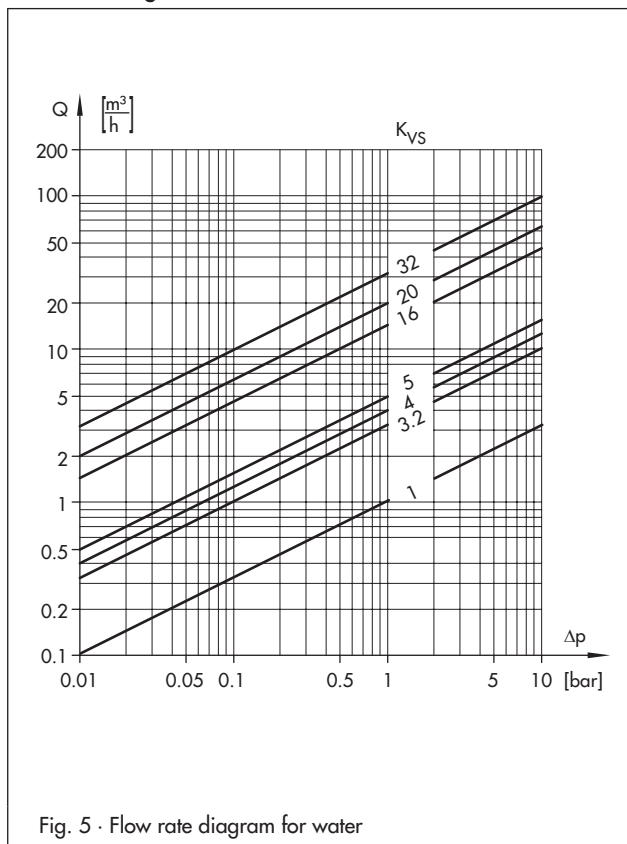

Fig. 5 · Flow rate diagram for water

Pressure-temperature diagram (acc. to DIN EN 12516-2)

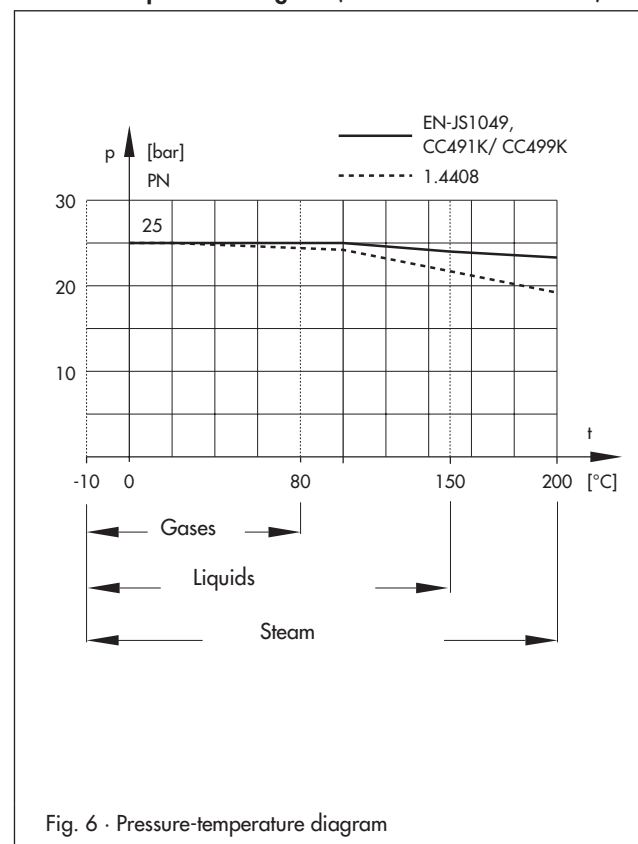

Fig. 6 · Pressure-temperature diagram

Table 6 · Dimensions and weights
Regulator with screwed ends · Red brass or stainless steel 1.4408

Connection	G ½	G ¾	G 1
Female thread G	½"	¾"	1"
Length L	65 mm	75 mm	90 mm
Width across flats SW	34 mm	34 mm	46 mm
Approx. weight	Red brass/stainless steel	1.0 kg	1.1 kg

Dimensions of regulator with screwed ends in mm

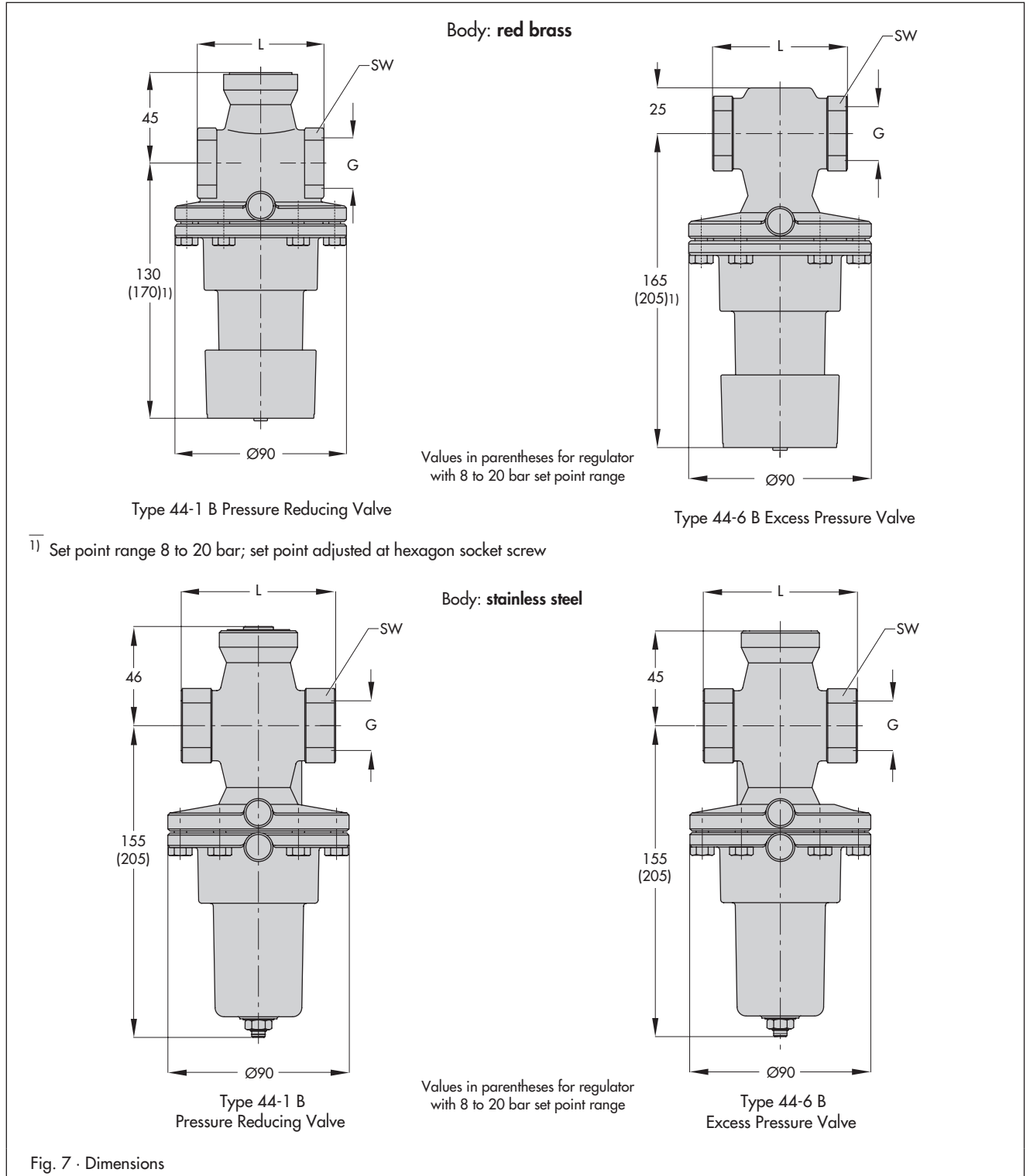
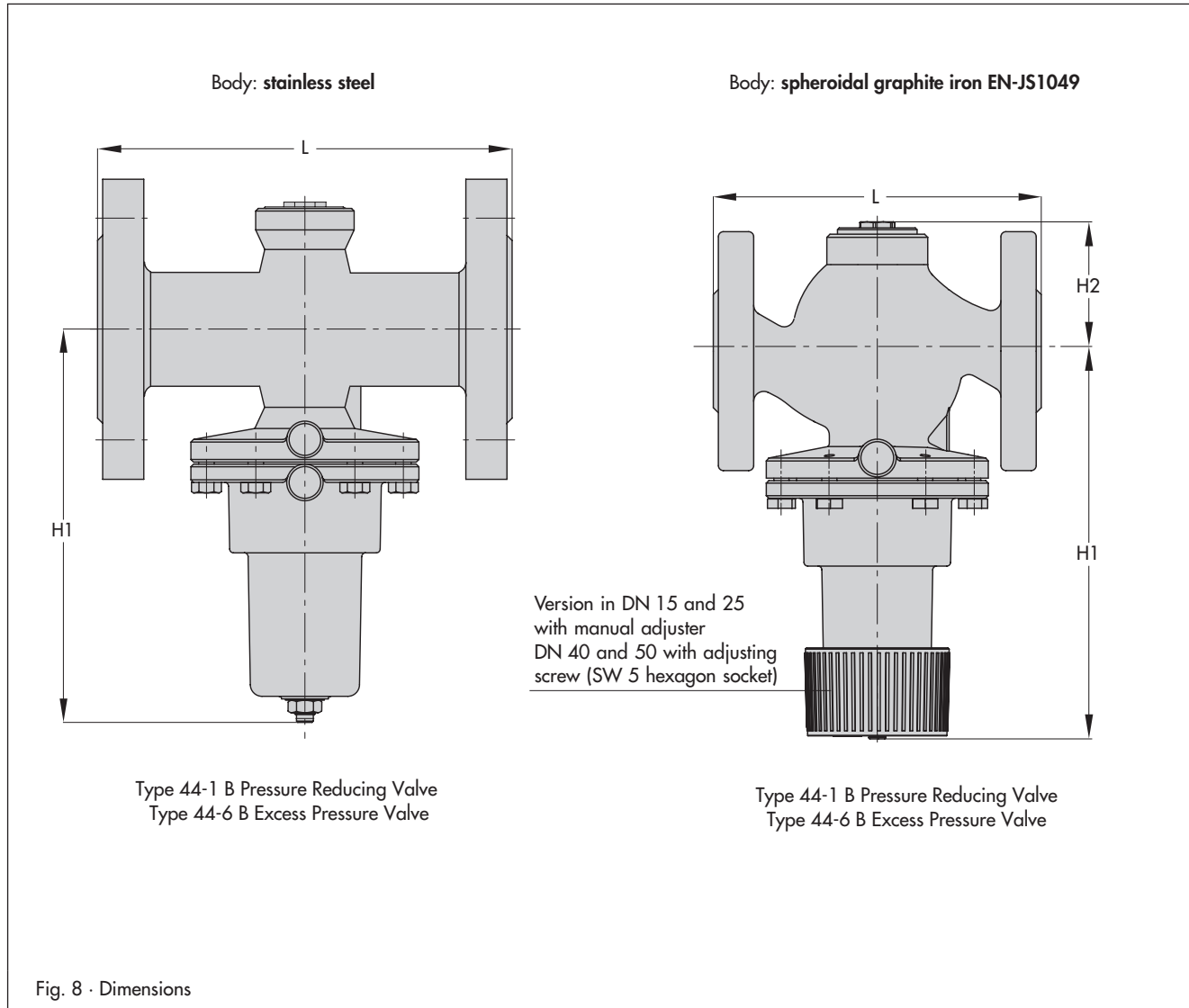

Table 7 · Dimensions and weights
Regulator with flanged body · Spheroidal graphite iron EN-JS1049 · Stainless steel 1.4408

Nominal size	DN 15	DN 25	DN 40	DN 50
Length L	130 mm	160 mm	200 mm	230 mm
Height H1	155 mm	155 mm	245 mm	245 mm
Height H2	–	–	95 mm	95 mm
Approx. weight	2.6 kg	4.2 kg	7 kg	8 kg

Dimensions of regulator with flanged body in mm



Ordering text

Type 44-1 B Pressure Reducing Valve for liquids and gases
or

Type 44-6 B Excess Pressure Valve for liquids, steam and gases

Body material: red brass, stainless steel or spheroidal graphite
iron

Version with screwed ends G ... or flanged body DN ...

Set point range ... bar, K_{VS} coefficient ...

Plug sealing: EPDM, FKM, FFKM, PTFE, metal seal

Version for steam (Type 44-6 B, special version)

Optionally, special version

Specifications subject to change without notice.



SAMSON AG · MESS- UND REGELTECHNIK
Weismüllerstraße 3 · 60314 Frankfurt am Main · Germany
Phone: +49 69 4009-0 · Fax: +49 69 4009-1507
Internet: <http://www.samson.de>

T 2626 EN