

# MOUNTING AND OPERATING INSTRUCTIONS



**EB 8394 EN**

Translation of original instructions



**Series 3725**

**Type 3725 Electropneumatic Positioner**

Firmware version 1.12



Edition June 2014

## Note on these mounting and operating instructions

These mounting and operating instructions assist you in mounting and operating the device safely. The instructions are binding for handling SAMSON devices.

- For the safe and proper use of these instructions, read them carefully and keep them for later reference.
- If you have any questions about these instructions, contact SAMSON's After-sales Service Department (aftersaleservice@samson.de).



The mounting and operating instructions for the devices are included in the scope of delivery. The latest documentation is available on our website at [www.samson.de](http://www.samson.de) > **Service & Support** > **Downloads** > **Documentation**.

## Definition of signal words

### **DANGER**

*Hazardous situations which, if not avoided, will result in death or serious injury*

### **WARNING**

*Hazardous situations which, if not avoided, could result in death or serious injury*

### **NOTICE**

*Property damage message or malfunction*

### **Note**

*Additional information*

### **Tip**

*Recommended action*

<b>1</b>	<b>Safety instructions and measures .....</b>	<b>6</b>
1.1	Notes on possible severe personal injury .....	9
1.2	Notes on possible personal injury .....	10
1.3	Notes on possible property damage .....	10
<b>2</b>	<b>Markings on the device .....</b>	<b>12</b>
2.1	Nameplate .....	12
2.2	Article code .....	13
<b>3</b>	<b>Design and principle of operation .....</b>	<b>14</b>
3.1	Mounting versions .....	14
3.2	Accessories and mounting parts .....	16
3.3	Travel tables .....	20
3.4	Technical data .....	21
3.5	Dimensions in mm .....	23
<b>4</b>	<b>Measures for preparation .....</b>	<b>25</b>
4.1	Unpacking .....	25
4.2	Transporting and lifting .....	25
4.2.1	Transporting .....	25
4.2.2	Lifting .....	25
4.3	Storage .....	25
<b>5</b>	<b>Mounting and start-up .....</b>	<b>26</b>
5.1	Lever and pin position .....	26
5.2	Direct attachment .....	28
5.2.1	Type 3277-5 and Type 2780-2 Actuators .....	28
5.2.2	Type 3277 Actuator .....	32
5.3	Attachment according to IEC 60534-6 .....	34
5.4	Attachment to Type 3372 Actuator (V2001) .....	36
5.5	Attachment to rotary actuators .....	38
5.5.1	Heavy-duty version .....	40
5.5.2	Mounting the Type 3710 Reversing Amplifier .....	42
5.6	Pneumatic connections .....	43
5.7	Connecting the supply air .....	43
5.7.1	Signal pressure connection .....	43
5.7.2	Supply pressure .....	44
5.8	Electrical connections .....	45
5.8.1	Electric power supply .....	46
5.8.2	Cable entry .....	46
5.8.3	Connecting the electrical power .....	46

## Contents

<b>6</b>	<b>Operation .....</b>	<b>48</b>
6.1	Operating controls .....	48
6.1.1	Capacitive keys.....	48
6.1.2	Volume restriction Q.....	48
6.1.3	Display .....	49
<b>7</b>	<b>Operating the positioner.....</b>	<b>50</b>
7.1	Adapting the display.....	51
7.2	Enabling configuration to change parameters.....	51
7.3	Adjusting the volume restriction Q.....	52
7.4	Entering the air action .....	53
7.5	Entering the direction of action.....	53
7.6	Limiting the signal pressure.....	54
7.7	Setting other parameters.....	55
7.8	Initialization .....	55
7.8.1	Canceling initialization.....	56
7.9	Zero calibration .....	57
7.9.1	Canceling zero calibration.....	58
7.10	Manual mode .....	58
7.11	Reset.....	59
<b>8</b>	<b>Servicing.....</b>	<b>60</b>
8.1	Cleaning the window in the cover.....	60
8.2	Preparation for return shipment.....	60
<b>9</b>	<b>Malfunctions .....</b>	<b>61</b>
9.1	Resetting error codes .....	62
9.2	Error codes.....	64
9.3	Emergency action .....	65
<b>10</b>	<b>Decommissioning and disassembly .....</b>	<b>66</b>
10.1	Decommissioning.....	66
10.2	Removing the positioner .....	66
10.3	Disposal.....	66
<b>11</b>	<b>Annex.....</b>	<b>67</b>
11.1	After-sales service .....	67
11.2	Code list.....	68
11.2.1	Parameter codes .....	68

Firmware revisions	
1.02 (old)	1.03 (new)
	Internal revisions
1.03 (old)	1.10 (new)
	Setting of the travel in steps of 0.5 mm (P4 parameter code)
	Monitoring of the end stops only during initialization and in manual mode
	To suppress common-mode interference on the signal lines, the D component of the positioner is switched off when the actuator is at a standstill.
1.10 (old)	1.11 (new)
	Internal revisions
1.11 (old)	1.12 (current version)
	Internal revisions

# 1 Safety instructions and measures

### Intended use

The SAMSON Type 3725 Positioner is mounted on pneumatic control valves and is used to assign the valve position to the control signal. The device is designed to operate under exactly defined conditions (e.g. operating pressure, temperature). Therefore, operators must ensure that the positioner is only used in applications where the operating conditions correspond to the technical data. In case operators intend to use the positioner in other applications or conditions than specified, contact SAMSON.

SAMSON does not assume any liability for damage resulting from the failure to use the device for its intended purpose or for damage caused by external forces or any other external factors.

➔ Refer to the technical data for limits and fields of application as well as possible uses.

### Reasonably foreseeable misuse

The Type 3725 Positioner is **not** suitable for the following applications:

- Use outside the limits defined during sizing and in the technical data

Furthermore, the following activities do not comply with the intended use:

- Use of non-original spare parts
- Performing maintenance activities not specified by SAMSON

### Qualifications of operating personnel

The positioner must be mounted, started up, and serviced by fully trained and qualified personnel only; the accepted industry codes and practices are to be observed. According to these mounting and operating instructions, trained personnel refers to individuals who are able to judge the work they are assigned to and recognize possible hazards due to their specialized training, their knowledge and experience as well as their knowledge of the applicable standards.

Explosion-protected versions of this device are to be operated only by personnel who has undergone special training or instructions or who is authorized to work on explosion-protected devices in hazardous areas.

### Personal protective equipment

No personal protective equipment is required for the direct handling of the positioner. Work on the control valve may be necessary when mounting or removing the positioner.

- Observe the requirements for personal protective equipment specified in the valve documentation.
- Check with the plant operator for details on further protective equipment.

### Revisions and other modifications

Revisions, conversions or other modifications to the product are not authorized by SAMSON. They are performed at the user's own risk and may lead to safety hazards, for example. Furthermore, the product may no longer meet the requirements for its intended use.

### Safety features

Upon failure of the air supply or electric signal, the positioner vents the actuator, causing valve to move to the fail-safe position determined by the actuator.

### Warning against residual hazards

The positioner has direct influence on the control valve. To avoid personal injury or property damage, plant operators and operating personnel must prevent hazards that could be caused in the control valve by the process medium, the operating pressure, the signal pressure or by moving parts by taking appropriate precautions. They must observe all hazard statements, warning and caution notes in these mounting and operating instructions, especially for installation, start-up, and service work.

If inadmissible motions or forces are produced in the pneumatic actuator as a result of the supply pressure level, it must be restricted using a suitable supply pressure reducing station.

### Responsibilities of the operator

The operator is responsible for proper operation and compliance with the safety regulations. Operators are obliged to provide these mounting and operating instructions to the operating personnel and to instruct them in proper operation. Furthermore, the operator must ensure that operating personnel or third persons are not exposed to any danger.

### Responsibilities of operating personnel

Operating personnel must read and understand these mounting and operating instructions as well as the specified hazard statements, warning and caution notes. Furthermore, the operating personnel must be familiar with the applicable health, safety and accident prevention regulations and comply with them.

## Safety instructions and measures

### Servicing explosion-protected devices

If a part of the device on which the explosion protection is based needs to be serviced, the device must not be put back into operation until a qualified inspector has assessed it according to explosion protection requirements, has issued an inspection certificate, or given the device a mark of conformity. Inspection by a qualified inspector is not required if the manufacturer performs a routine test on the device before putting it back into operation. Document the passing of the routine test by attaching a mark of conformity to the device. Replace explosion-protected components only with original, routine-tested components by the manufacturer.

Devices that have already been operated outside hazardous areas and are intended for future use inside hazardous areas must comply with the safety requirements placed on serviced devices. Before being operated inside hazardous areas, test the devices according to the specifications for servicing explosion-protected devices.

### Maintenance, calibration, and work on equipment

- ➔ Only use intrinsically safe current/voltage calibrators and measuring instruments for interconnection with intrinsically safe circuits to check or calibrate the equipment inside or outside hazardous areas.
- ➔ Observe the maximum permissible values specified in the certificates for intrinsically safe circuits.

### Referenced standards and regulations

Devices with a CE marking fulfill the requirements of the Directives 2014/34/EU and 2014/30/EU. The declaration of conformity is included at the end of these instructions.

### Referenced documentation

The following documents apply in addition to these mounting and operating instructions:

- The mounting and operating instructions of the components on which the positioner is mounted (valve, actuator, valve accessories, etc.).



## 1.1 Notes on possible severe personal injury

### DANGER

#### **Risk of the formation of an explosive atmosphere.**

Incorrect installation, operation, or maintenance of the positioner in potentially explosive atmospheres may lead to ignition of the atmosphere and cause death.

- The following regulations apply to installation in hazardous areas: EN 60079-14 (VDE 0165, Part 1).
- Installation, operation, or maintenance of the positioner must only be performed by personnel who has undergone special training or instructions or who is authorized to work on explosion-protected devices in hazardous areas.

## 1.2 Notes on possible personal injury

### **⚠ WARNING**

#### **Risk of personal injury due to moving parts on the valve.**

During initialization of the positioner and during operation, the actuator stem moves through its entire travel range. Injury to hands or fingers is possible if they are inserted into the valve.

- During initialization, do not insert hands or fingers into the valve yoke and do not touch any moving valve parts.

## 1.3 Notes on possible property damage

### **ⓘ NOTICE**

#### **Risk of damage to the positioner due to incorrect mounting position.**

- Do not mount the positioner with the back of the device/vent opening facing upward.
- Do not seal the vent opening when the device is installed on site.

#### **Risk of malfunction due to incorrect sequence during start-up.**

The positioner can only work properly if the mounting and start-up are performed in the prescribed sequence.

- Perform mounting and start-up as described in section 5 in page 26.

#### **An incorrect electric signal will damage the positioner.**

A current source must be used to provide the electrical power for the positioner.

- Only use a current source and never a voltage source.

#### **Incorrect assignment of the terminals will damage the positioner and will lead to malfunction.**

For the positioner to function properly, the prescribed terminal assignment must be observed.

- Connect the electrical wiring to the positioner according to the prescribed terminal assignment.

**Malfunction due to initialization not yet completed.**

The initialization causes the positioner to be adapted to the mounting situation. After initialization is completed, the positioner is ready to use.

- Initialize the positioner on the first start-up.
- Re-initialize positioner after changing the mounting position.

**Risk of positioner damage due to incorrect grounding of the electric welding equipment.**

- Do not ground electric welding equipment near to the positioner.

**Incorrect cleaning will damage the window.**

The window is made of Makrolon® and will be damaged when cleaned with abrasive cleaning agents or agents containing solvents.

- Do not rub the window dry.
- Do not use any cleaning agents containing chlorine or alcohol or abrasive cleaning agents.
- Use a non-abrasive, soft cloth for cleaning.

**Risk of damage to the housing cover due to excessively high torque being applied when tightening the housing screws.**

- Tighten the cover screws with a tightening torque of 0.8 Nm at the maximum.

## 2 Markings on the device

### 2.1 Nameplate

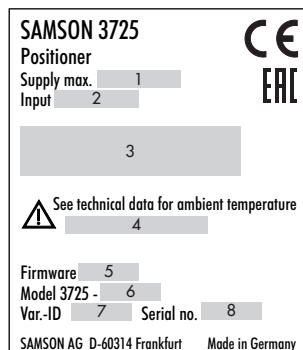

- 1 Max. supply pressure
- 2 Signal range
- 3 Type of protection for explosion-protected devices
- 4 Temperature limits in the test certificates for the explosion-protected devices
- 5 Firmware version
- 6 Model no.
- 7 Configuration ID
- 8 Serial number

## 2.2 Article code

Positioner		Type 3725-						x	x	x	0	0	0	0	x	0	0
With LCD and autotune, 4 to 20 mA reference variable																	
Explosion protection <sup>1)</sup>																	
Without		0	0	0													
<b>ATEX</b>	II 2 G Ex ia IIC T4 Gb	1	1	0													
<b>CCC Ex</b>	Ex ia II T4 Gb	1	1	2													
<b>EAC</b>	1Ex ia IIC T4 Gb X	1	1	3													
<b>TR CMU 1055</b>	II 2 G Ex ia IIC T4 Gb	1	1	6													
<b>CSA c/us</b>	Ex ia IIC T4; Class I, Zone 0, AEx ia IIC T4; Class I, Div. 1, Groups A, B, C & D	1	3	0													
Shipbuilding certificate																	
Without																	0
Bureau Veritas certification																	1

<sup>1)</sup> See Table 1 for details on explosion protection certificates.

**Table 1: Summary of explosion protection certificates**

Type	Certification			Type of protection
3725-1000	<b>ATEX</b>	Number	PTB 11 ATEX 2020 X	II 2 G Ex ia IIC T4 Gb
		Date	2019-02-25	
3725-112	<b>CCC Ex</b>	Number	2021322307003871	Ex ia II T4 Gb
		Date	2021-04-05	
		Valid until	026-04-04	
3725-113	<b>EAC</b>	Number	RU C-DE.HA65.B.00510/20	1Ex ia IIC T4 Gb X
		Date	2020-03-18	
		Valid until	2025-03-18	
3725-116	<b>TR CMU 1055</b>	Number	ZETC/35/2021	II 2 G Ex ia IIC T4 Gb
		Date	2021-07-26	
		Valid until	2024-07-25	
3725-130	<b>CSA c/us</b>	Number	2703735 X	Ex ia IIC T4; Class I, Zone 0, AEx ia IIC T4; Class I, Div. 1, Groups A, B, C & D
		Date	2014-06-03	

**Table 2: Approval certificates for ships**

<b>BV type approval certificate</b>	Number	46564/B0 BV.pdf
	Date	2022-01-11
	Valid until	2027-01-11

### 3 Design and principle of operation

The Type 3725 Electropneumatic Positioner is mounted on pneumatic control valves and is used to assign the valve position (controlled variable  $x$ ) to the control signal (reference variable  $w$ ). The positioner compares the electric control signal of a control system to the travel or opening angle of the control valve and issues a signal pressure (output variable  $y$ ) for the pneumatic actuator.

The positioner mainly consists of the following components (see Fig. 1):

- Magneto-resistive sensor (2)
- Analog i/p converter (6) with a downstream air capacity booster (7)
- Electronics unit with microcontroller (4)

The travel or opening angle is measured by the pick-up lever, non-contact magneto-resistive sensor and downstream electronics.

The pick-up lever is connected to a magnet inside the device. The motion of the pick-up lever causes the direction of the magnetic field to change. This change is sensed by the sensor. The electronics unit determines the current position of the actuator stem or opening angle from this information.

The position of the actuator stem or opening angle is transmitted to the microcontroller (3) over the A/D converter (4). The PD control algorithm in the microprocessor compares this actual position to the 4 to 20 mA control signal after it has been converted by the A/D converter (3). In case of a system devi-

ation, the activation of the i/p module (6) is changed so that the actuator of the valve (1) is pressurized or vented accordingly over the downstream booster (7). The supply air is supplied to the booster and the pressure regulator (8).

The output signal pressure supplied by the booster can be limited to 2.3 bar by software.

The volume restriction Q (10) is used to optimize the positioner by adapting it to the actuator.

#### Tight-closing function

The pneumatic actuator is completely filled with air or vented as soon as the reference variable falls below 1 % or exceeds 99 % (see end positions set in P10 and P11 parameter codes).

### 3.1 Mounting versions

The Type 3725 Positioner is suitable for the following types of attachment:

- Direct attachment to SAMSON Type 3277 and Type 2780-2 Actuators
  - Attachment to actuators according to IEC 60534-6 (NAMUR)
  - Attachment to Type 3372 Actuator (Series V2001 Valves)
  - Attachment to rotary actuators according to VDI/VDE 3845
- ➔ Refer to section 5.2 onwards for a description of the types of attachment.

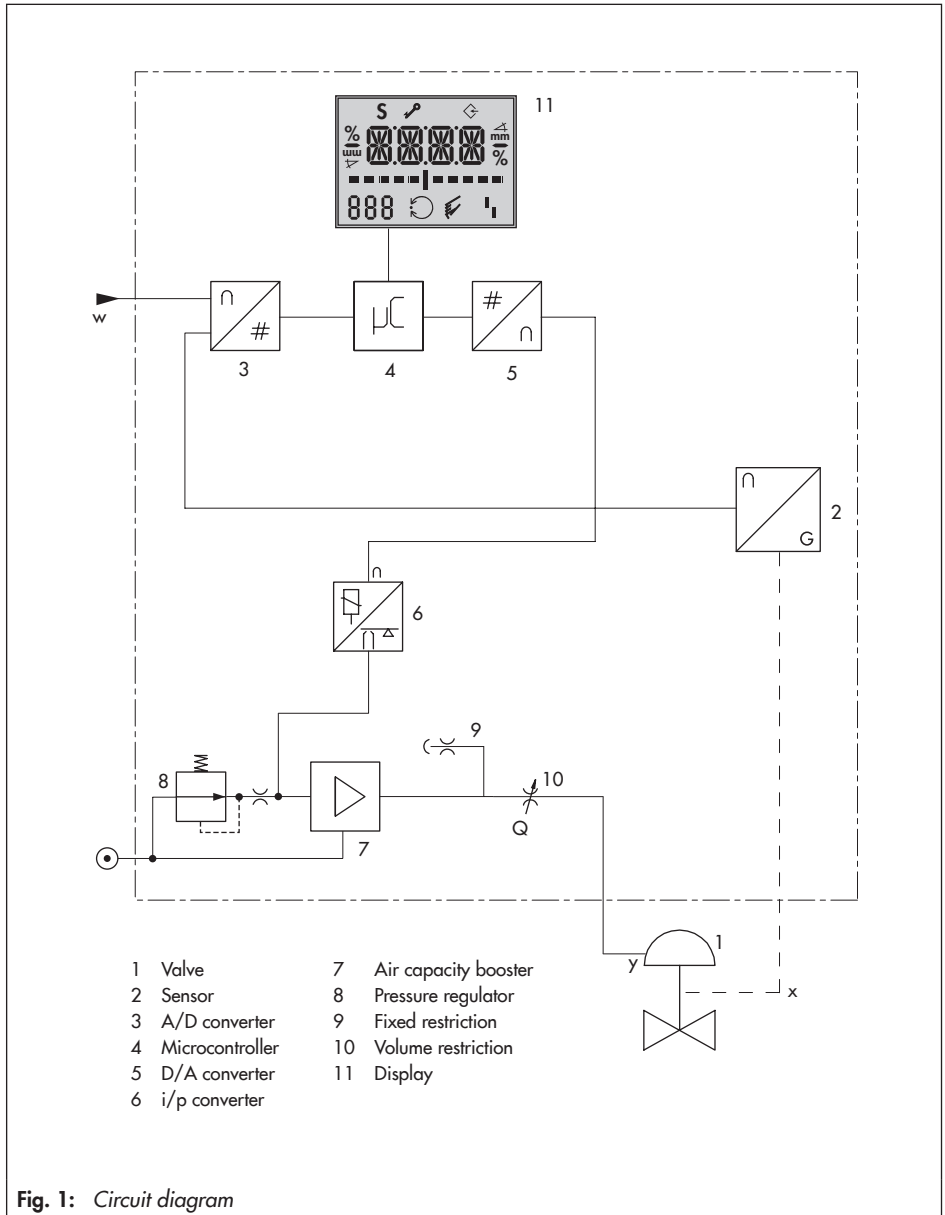

## 3.2 Accessories and mounting parts

Table 3: Direct attachment to Type 3277-5 and Type 2780-2 Actuators (see section 5.2)		Order no.
<b>Mounting parts</b>		
For actuators up to 120 cm <sup>2</sup>		1402-0239
<b>Accessories for actuator</b>		
Switchover plate for Type 3277-5xxxxxx.01 Actuator		1400-6822
Connecting plate for additional attachment of, e.g. a solenoid valve: G 1/8		1400-6823
<b>Accessories for positioner</b>		
Connecting plate (6)	G 1/4	1402-0235
	1/4 NPT	1402-0236
Pressure gauge bracket (7)	G 1/4	1402-0237
	1/4 NPT	1402-0238
Pressure gauge bracket for combination with Type 4708-55 Supply Pressure Regulator		1402-1515
Pressure gauge mounting kit (8) up to max. 6 bar (output/supply)	Stainless steel/brass	1402-0938
	Stainless steel/ stainless steel	1402-0939

Table 4: Direct attachment to Type 3277 (section 5.2.2)		Order no.
<b>Mounting parts</b>		
Actuators 175, 240, 350, 355, 700, 750 cm <sup>2</sup>		1402-0240
<b>Accessories</b>		
Connection block with seals and screw	G 1/4	1402-0241
	1/4 NPT	1402-0242
Pressure gauge mounting kit up to max. 6 bar (output/supply)	Stainless steel/brass	1402-0938
	Stainless steel/ stainless steel	1402-0939



Table 5: Pipe connections for Type 3277 (direct attachment)				
Pipe connection	Actuator size	Material	Connection	Order no.
Piping with screw fittings – for fail-safe action "actuator stem retracts" – with air purging of the top diaphragm chamber	175 cm <sup>2</sup>	Steel	G ¼ / G ¾	1402-0930
			¼ NPT/ ¾ NPT	1402-0958
		Stainless steel	G ¼ / G ¾	1402-0950
			¼ NPT/ ¾ NPT	1402-0964
	240 cm <sup>2</sup>	Steel	G ¼ / G ¾	1402-0927
			¼ NPT/ ¾ NPT	1402-0959
		Stainless steel	G ¼ / G ¾	1402-0951
			¼ NPT/ ¾ NPT	1402-0965
	350 cm <sup>2</sup>	Steel	G ¼ / G ¾	1402-0928
			¼ NPT/ ¾ NPT	1402-0960
		Stainless steel	G ¼ / G ¾	1402-0952
			¼ NPT/ ¾ NPT	1402-0966
	355 cm <sup>2</sup>	Steel	G ¼ / G ¾	1402-0956
			¼ NPT/ ¾ NPT	1402-0961
		Stainless steel	G ¼ / G ¾	1402-0953
			¼ NPT/ ¾ NPT	1402-0967
700 cm <sup>2</sup>	Steel	G ¼ / G ¾	1402-0929	
		¼ NPT/ ¾ NPT	1402-0962	
	Stainless steel	G ¼ / G ¾	1402-0954	
		¼ NPT/ ¾ NPT	1402-0968	
750 cm <sup>2</sup>	Steel	G ¼ / G ¾	1402-0957	
		¼ NPT/ ¾ NPT	1402-0963	
	Stainless steel	G ¼ / G ¾	1402-0955	
		¼ NPT/ ¾ NPT	1402-0969	

## Design and principle of operation

Table 6: Attachment to NAMUR rib or attachment to rod-type yokes according to IEC 60534-6 (section 5.3)		Order no.
<b>5 to 50 mm travel, lever already on positioner</b>		
For actuators		1402-0330
Actuators from other manufacturers and Type 3271 with 120 to 750 cm <sup>2</sup> effective areas		
<b>Accessories</b>		
Connecting plate	G ¼	1402-0235
	¼ NPT	1402-0236
Pressure gauge bracket	G ¼	1402-0237
	¼ NPT	1402-0238
Pressure gauge mounting kit up to max. 6 bar (output/supply)	Stainless steel/brass	1402-0938
	Stainless steel/st. steel	1402-0939

Table 7: Attachment to rotary actuators (section 5.5)		Order no.
<b>Light version</b>		
VDI/VDE 3845 (September 2010), level 1 <sup>1)</sup> , AA1 size		1402-0243
VDI/VDE 3845 (September 2010), level 2 <sup>1)</sup> , AA2 size		1402-0244
VE TEC Type S160 Actuator or SAMSON Type 3278 Rotary Actuator (160 cm <sup>2</sup> )		1402-0294
VE TEC Type S320		1402-0295
<b>Heavy-duty version</b>		
VDI/VDE 3845 (September 2010), level 1 <sup>1)</sup> , AA1 to AA4 size		1402-1097
VDI/VDE 3845 (September 2010), level 2 <sup>1)</sup>		1402-1099
VE TEC Type S160/R		1402-1098
<b>Accessories</b>		
Connecting plate	G ¼	1402-0235
	¼ NPT	1402-0236
Pressure gauge bracket	G ¼	1402-0237
	¼ NPT	1402-0238
Pressure gauge mounting kit up to max. 6 bar (output/supply)	Stainless steel/brass	1402-0938
	Stainless steel/st. steel	1402-0939
Connecting plate for Type 3710 Reversing Amplifier		1402-0512

<sup>1)</sup> See page 24 for details.

<b>Table 8: General accessories/spare parts</b>	<b>Order no.</b>
<b>Cable gland M20x1.5</b>	
Black plastic	8808-1011
Blue plastic	8808-1012
Nickel-plated brass	1890-4875
Stainless steel 1.4305	8808-0160
<b>Adapter M20x1.5 to ½ NPT</b>	
Powder-coated aluminum	0310-2149
Stainless steel	1400-7114
<b>Cover</b>	
Polycarbonate	1992-6367
<b>Brief instructions inside cover</b>	
German	0190-6173
English	0190-6174

### 3.3 Travel tables

**i Note**

The **M** lever is included in the scope of delivery.

#### Direct attachment to Type 3277-5 and Type 3277 Actuators

Actuator size [cm <sup>2</sup> ]	Rated travel [mm]	Adjustment range at positioner			Required lever	Assigned pin position
		Min.	Travel	Max.		
120	7.5	5.0 mm	to	16.0 mm	M	25
120/175/240/350	15	7.0 mm	to	22.0 mm	M	35
355/700/750	30	10.0 mm	to	32.0 mm	M	50

#### Direct attachment to Type 2780-2 Actuator

Actuator size [cm <sup>2</sup> ]	Rated travel [mm]	Adjustment range at positioner			Required lever	Assigned pin position
		Min.	Travel	Max.		
120	6/12	5.0 mm	to	16.0 mm	M	25
120	15	7.0 mm	to	22.0 mm	M	35

#### Attachment according to IEC 60534-6 (NAMUR)

SAMSON Type 3271 Actuator		Travel of other valves		Required lever	Assigned pin position
Size [cm <sup>2</sup> ]	Rated travel [mm]	Min.	Max.		
120	7.5	5.0 mm	16.0/25.0 <sup>1)</sup> mm	M	25
120/175/240/350	15	7.0 mm	22.0/35.0 <sup>1)</sup> mm	M	35
700/750	7.5				
355/700/750	15/30	10.0 mm	32.0/50.0 <sup>1)</sup> mm	M	50

<sup>1)</sup> When 'MAX' is selected as the nominal range (P4 code, see page 68)

#### Attachment to rotary actuators according to VDI/VDE 3845

Rotary actuators			Required lever	Assigned pin position
Min.	Opening angle	Max.		
24°	to	100°	M	90°

### 3.4 Technical data

Type 3725 Positioner	
Travel (adjustable)	Direct attachment to Type 3277: 5 to 30 mm Direct attachment to Type 2780-2: 6/12/15 mm Attachment to Type 3372 Actuator: 15/30 mm Attachment according to IEC 60534-6 (NAMUR): 5 to 50 mm Attachment to rotary actuators: 24 to 100°
Reference variable w (reverse polarity protection)	4 to 20 mA signal range · Two-wire device
Static destruction limit	Split-range operation 4 to 11.9 mA and 12.1 to 20 mA ±33 V
Minimum current	3.8 mA
Load impedance	Max. 6.3 V (corresponds to 315 Ω at 20 mA)
Supply air	Supply air: 1.4 to 7 bar (20 to 105 psi)
Air quality acc. to ISO 8573-1	Max. particle size and density: Class 4 · Oil content: Class 3 · Pressure dew point: Class 3 or at least 10 K below the lowest ambient temperature to be expected
Signal pressure (output)	0 bar up to the supply pressure · Can be limited to approx. 2.3 bar by software
Characteristic	3 characteristics for globe valves · 9 characteristics for rotary valves
Hysteresis	≤ 0.3 %
Sensitivity	≤ 0.1 %
Transit time	Only for actuators with initialization time > 0.5 s <sup>1)</sup>
Direction of action	w/x reversible
Air consumption	≤ 100 l <sub>n</sub> /h with a supply pressure up to 6 bar and a signal pressure of 0.6 bar
Air output capacity	
To fill actuator with air	At Δp 6 bar: 8.5 m <sub>n</sub> <sup>3</sup> /h
To vent actuator	At Δp 6 bar: 14.0 m <sub>n</sub> <sup>3</sup> /h
	At Δp = 1.4 bar: 3.0 m <sub>n</sub> <sup>3</sup> /h, K <sub>Vmax</sub> (20 °C) = 0.09
	At Δp = 1.4 bar: 4.5 m <sub>n</sub> <sup>3</sup> /h, K <sub>Vmax</sub> (20 °C) = 0.15
Permissible ambient temperature	-20 to +80 °C -25 to +80 °C with metal cable gland The limits in the test certificates additionally apply for explosion-protected versions

<sup>1)</sup> For faster actuators, a volume restriction must be used. Otherwise, the initialization cannot be performed successfully.

## Design and principle of operation

Safety	
Influences	Temperature: $\leq 0.15 \text{ \%}/10 \text{ K}$ Effect of vibration: $\leq 0.25 \text{ \%}$ up to 2000 Hz and 4 g according to IEC 770 Supply air: None
Electromagnetic compatibility	Complying with EN 61000-6-2, EN 61000-6-3 and NAMUR Recommendation NE 21
Explosion protection <sup>1)</sup>	Intrinsic safety: <b>ATEX, STCC, CSA, GOST</b>
Degree of protection	IP 66
Compliance	<b>CE · EAC</b>
Materials	
Housing	Polyphthalamide (PPA)
Cover	Polycarbonate (PC) <sup>2)</sup>
External parts	Stainless steel 1.4571 and 1.4301
Cable gland	M20x1.5, black polyamide (PA)
Vent plugs	High-density polyethylene (PE-HD)
<b>Weight</b>	<b>Approx. 0.5 kg</b>

<sup>1)</sup> See Table 1 on page 13 for details on explosion protection certificates.

<sup>2)</sup> Makrolon®

### 3.5 Dimensions in mm

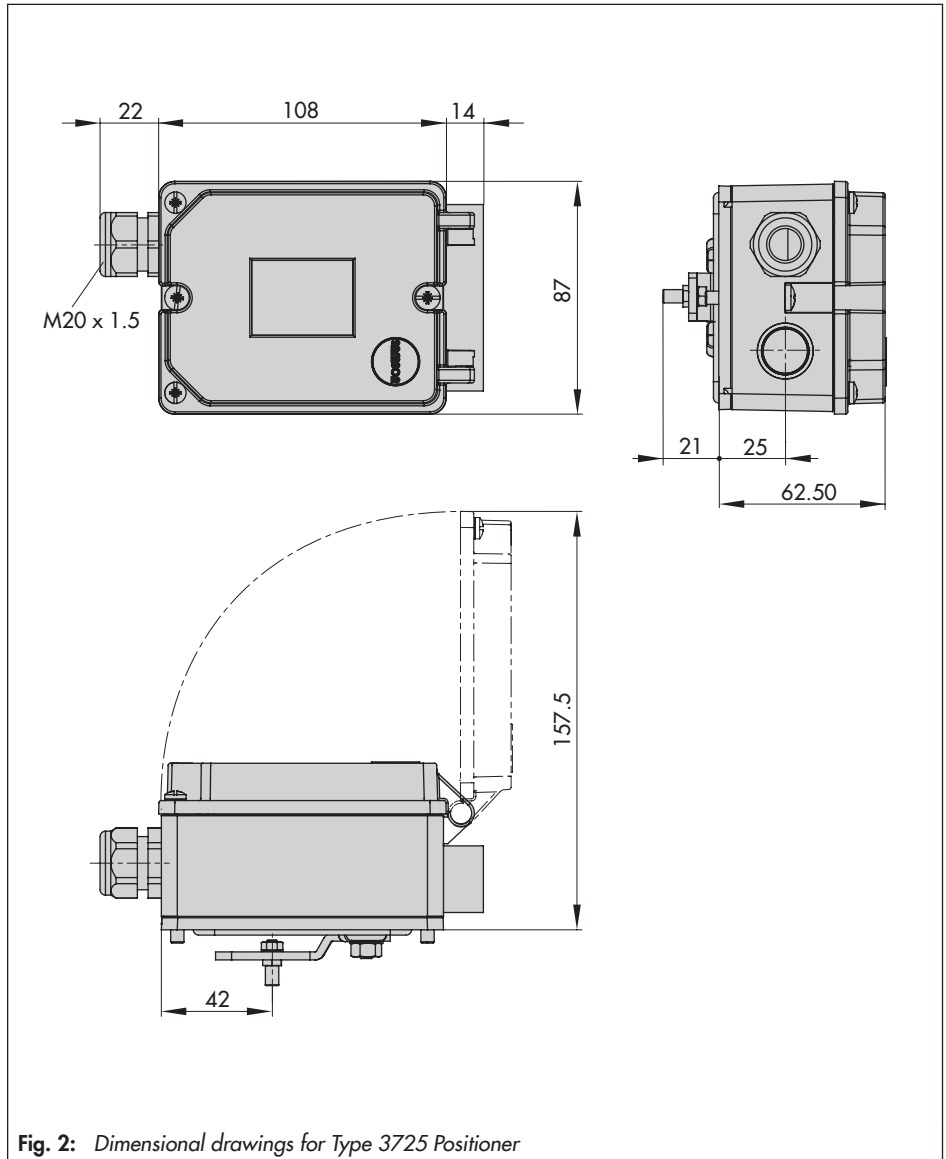
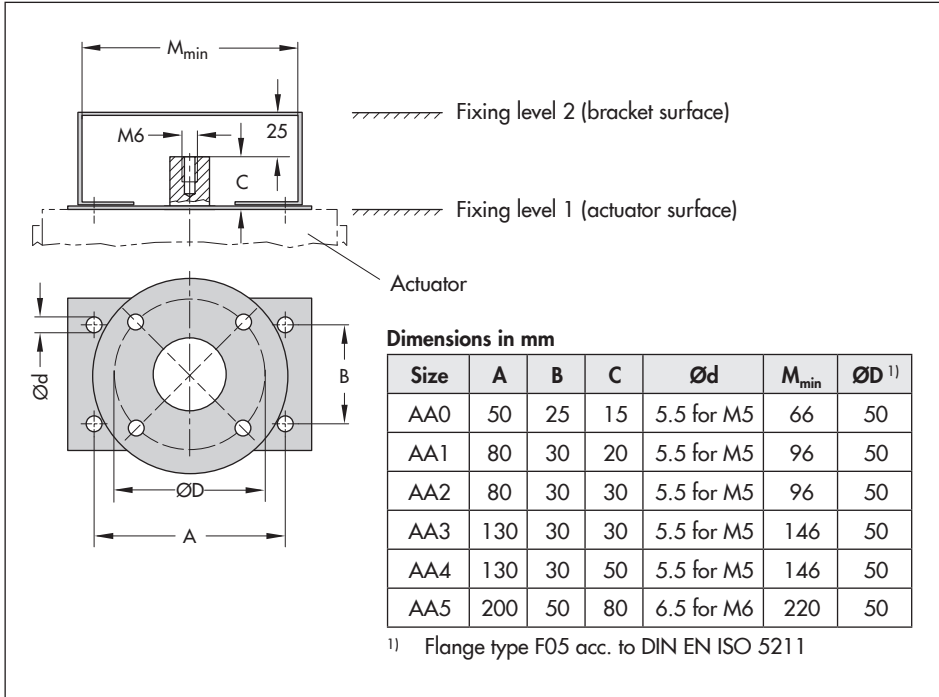

Fig. 2: Dimensional drawings for Type 3725 Positioner

## Design and principle of operation

### Fixing levels according to VDI/VDE 3845 (September 2010)





## 4 Measures for preparation

After receiving the shipment, proceed as follows:

1. Check the scope of delivery. Compare the shipment received against the delivery note.
2. Check the shipment for transportation damage. Report any transportation damage.

### 4.1 Unpacking

#### ! NOTICE

*Risk of positioner damage due to foreign particles entering it.*

*Do not remove the packaging and protective film/protective caps until immediately before mounting and start-up.*

1. Remove the packaging from the positioner.
2. Dispose of the packaging in accordance with the valid regulations.

### 4.2 Transporting and lifting

#### 4.2.1 Transporting

- Protect the positioner against external influences (e.g. impact).
- Protect the positioner against moisture and dirt.
- Observe transport temperature depending on the permissible ambient temperature (see technical data in section 3.4).

#### 4.2.2 Lifting

Due to the low service weight, lifting equipment is not required to lift the positioner.

### 4.3 Storage

#### ! NOTICE

*Risk of positioner damage due to improper storage.*

- Observe storage instructions.
- Avoid long storage times.
- Contact SAMSON in case of different storage conditions or long storage periods.

#### Storage instructions

- Protect the positioner against external influences (e.g. impact, shocks, vibration).
- Do not damage the corrosion protection (coating).
- Protect the positioner against moisture and dirt. In damp spaces, prevent condensation. If necessary, use a drying agent or heating.
- Observe storage temperature depending on the permissible ambient temperature (see technical data in section 3.4).
- Store positioner with closed cover.
- Seal pneumatic and electrical connections.

# 5 Mounting and start-up

---

### ⚠ NOTICE

*Risk of malfunction due to incorrect sequence of mounting, installation, and start-up. Observe the prescribed sequence.*

---

→ Sequence to be kept on mounting, installing, and starting up the positioner:

**1. Remove the protective caps from the pneumatic connections.**

**2. Mount the positioner on the valve.**

→ Section 5.2 onwards

**3. Perform pneumatic installation.**

→ Section 5.6 onwards

**4. Perform electrical installation.**

→ Section 5.8 onwards

**5. Perform the settings.**

→ Section 7 onwards

**The following applies when mounting the positioner:**

→ **Do not mount the positioner with the vent opening (Fig. 4) facing upward.**

→ **Do not seal the vent opening.**

**The following applies to the housing cover of the positioner:**

→ **Tighten the cover screws with a tightening torque of 0.8 Nm at the maximum.**

## 5.1 Lever and pin position

The positioner is adapted to the actuator and to the rated travel by the lever on the back of the positioner and the pin inserted into the lever.

The travel tables on page 20 show the assignment between the required lever and pin position.

The positioner is equipped with the **M** lever (pin position **35**) as standard (see Fig. 3).

**Removing the lever and changing the pin position:**

---

### ⚠ NOTICE

*Incorrect removal of the lever will damage the positioner.*

*Only remove the lever when it is positioned at the bottom mechanical stop.*

---

1. Move the lever to the bottom mechanical stop (see Fig. 4) and hold it in place. Undo and remove the nut using a wrench (width across flats SW 10).
2. Remove the lever from the shaft.
3. Insert pin in position as listed in the travel table.
4. Fasten the lever.

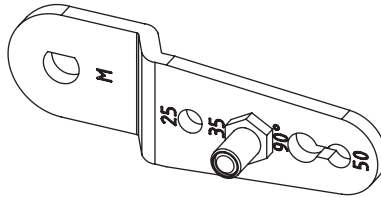

Fig. 3: M lever with pin position 35

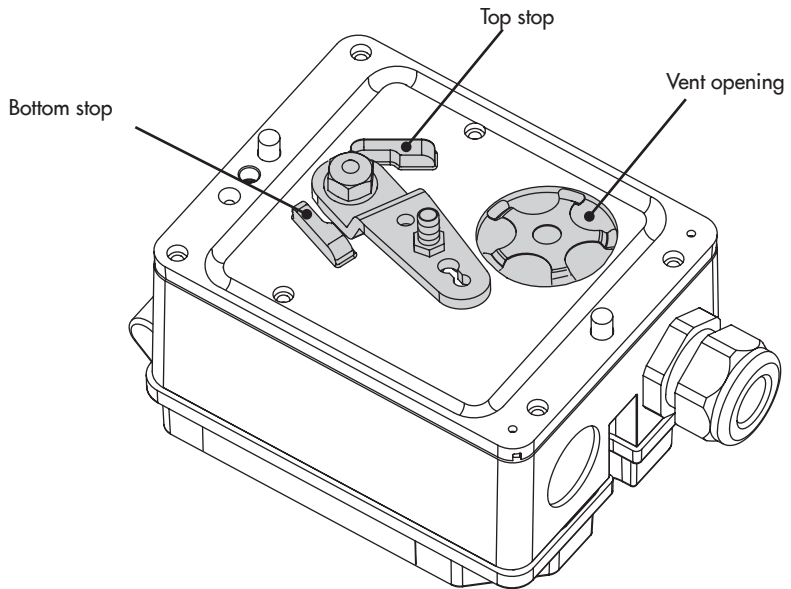

Fig. 4: Mechanical stops and vent opening

### 5.2 Direct attachment

#### 5.2.1 Type 3277-5 and Type 2780-2 Actuators

- ➔ Required mounting parts and accessories: Table 3 on page 16.
- ➔ Observe travel tables on page 20.

##### Actuator with 120 cm<sup>2</sup> diaphragm area

Depending on the type of positioner attachment, the signal pressure is routed either left or right of the yoke through a hole to the actuator diaphragm.

- ➔ Depending on the fail-safe action of the actuator "actuator stem extends" or "actuator stem retracts", first attach the switchover plate (9) to the actuator yoke (while aligning it with the corresponding symbol for left or right attachment according to the marking, see Fig. 6).

1. Mount connecting plate (6) or pressure gauge bracket (7) with pressure gauges on the positioner, making sure the two seals (6.1) are seated properly.
2. Screw the screw plug (4) on the back of the positioner into the hole below it (park position) (see Fig. 8) and seal the signal pressure output on the connecting plate (6) or on the pressure gauge bracket (7) with the stopper (5) included in the accessories.
3. Place follower clamp (3) on the actuator stem, align it and screw tight so that the mounting screw is located in the groove of the actuator stem.

4. **15 mm travel:** Keep the follower pin (2) on the M lever (1) on the back of the positioner in the pin position 35 (delivered state). **7.5 mm travel:** Remove the follower pin (2) from the pin position 35, reposition it in the hole for pin position 25 and screw tight.
5. Insert formed seal (15) into the groove of the positioner housing.
6. Place positioner on the actuator in such a manner that the follower pin (2) rests on top of the follower clamp (3). While doing this, press on the ribbed area shown in Fig. 5 to lock the pick-up lever in the top position. The lever (1) must rest on the follower clamp with spring force.

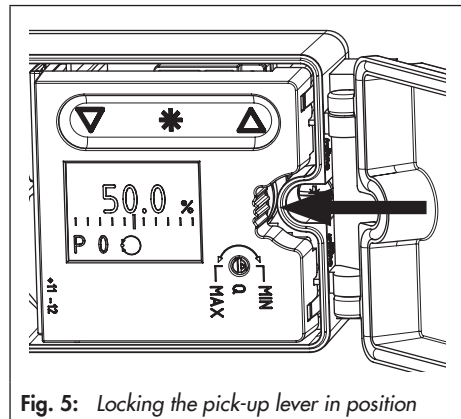
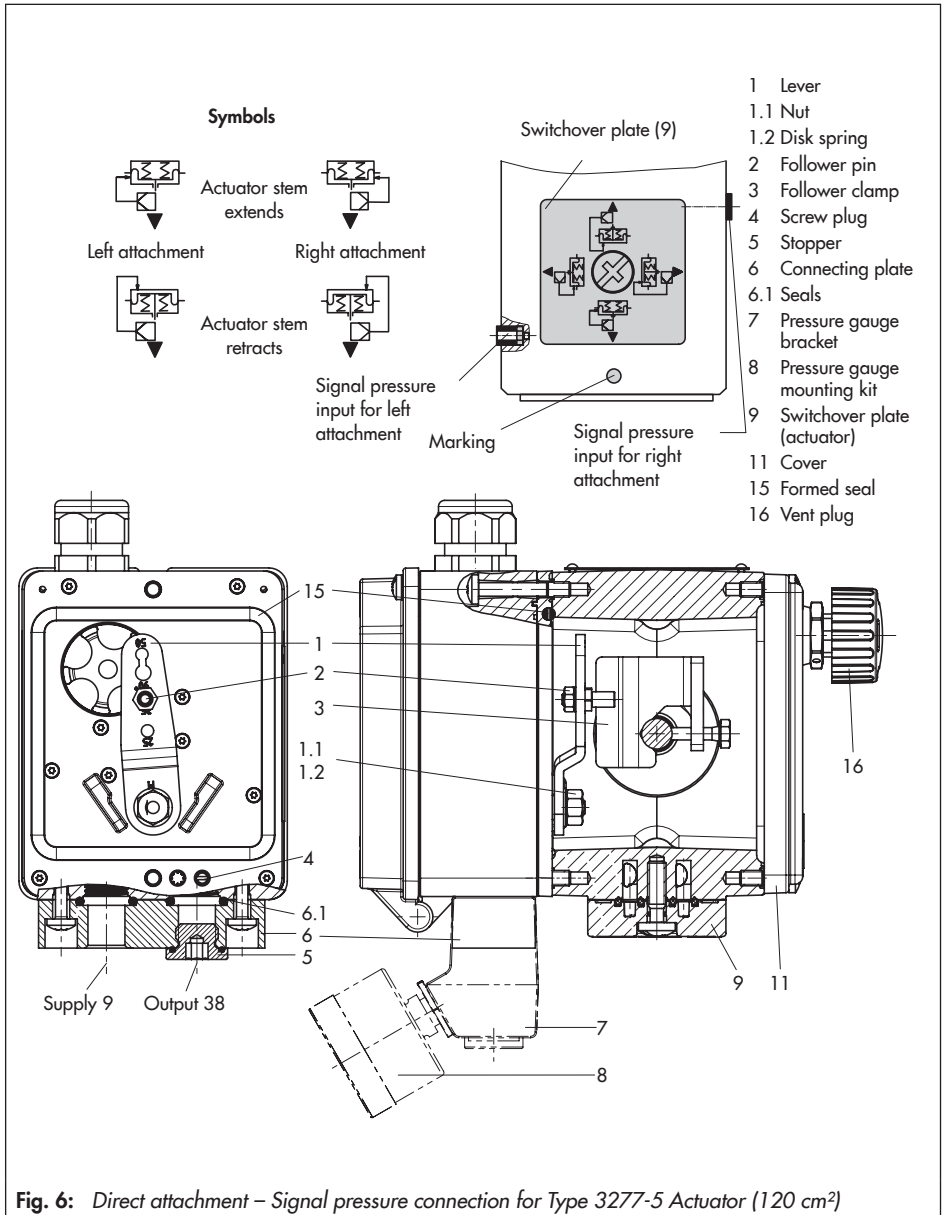

Fig. 5: Locking the pick-up lever in position

7. Mount the positioner on the actuator using the two fixing screws.



## Mounting and start-up

8. Mount cover (11) on the other side.  
Make sure that the vent plug is located at the bottom when the control valve is installed to allow any condensed water that collects to drain off (Fig. 7).

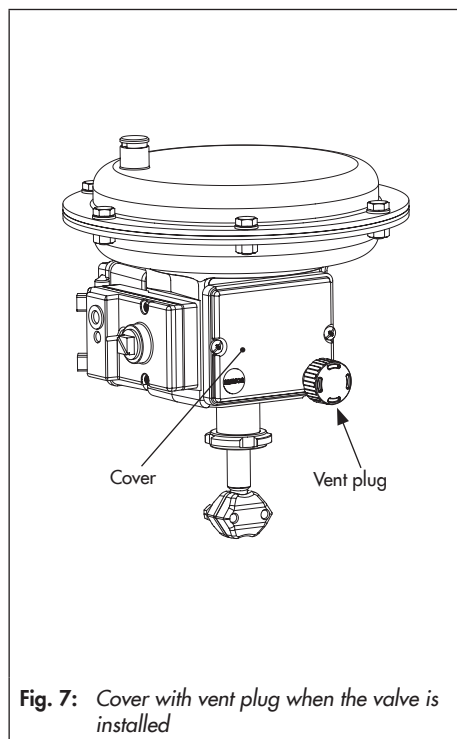

**Fig. 7:** Cover with vent plug when the valve is installed

### Additional solenoid valve

If a solenoid valve is additionally mounted onto the actuator, the signal pressure port at the back of the positioner must be sealed (see Fig. 8). To do this, unscrew the screw plug located in the middle hole (screw plug in park position) and screw it into the signal pressure port to seal it.

In this case, route the signal pressure from the signal pressure output to the actuator over the connecting plate (6) or pressure gauge bracket (7). The connecting plate (accessories for the actuator) replaces the switchover plate (9).

---

#### **i Note**

*The switchover plate and connecting plate are accessories for the actuator (120 cm<sup>2</sup>). They are listed in section 3.2 on page 16.*

---

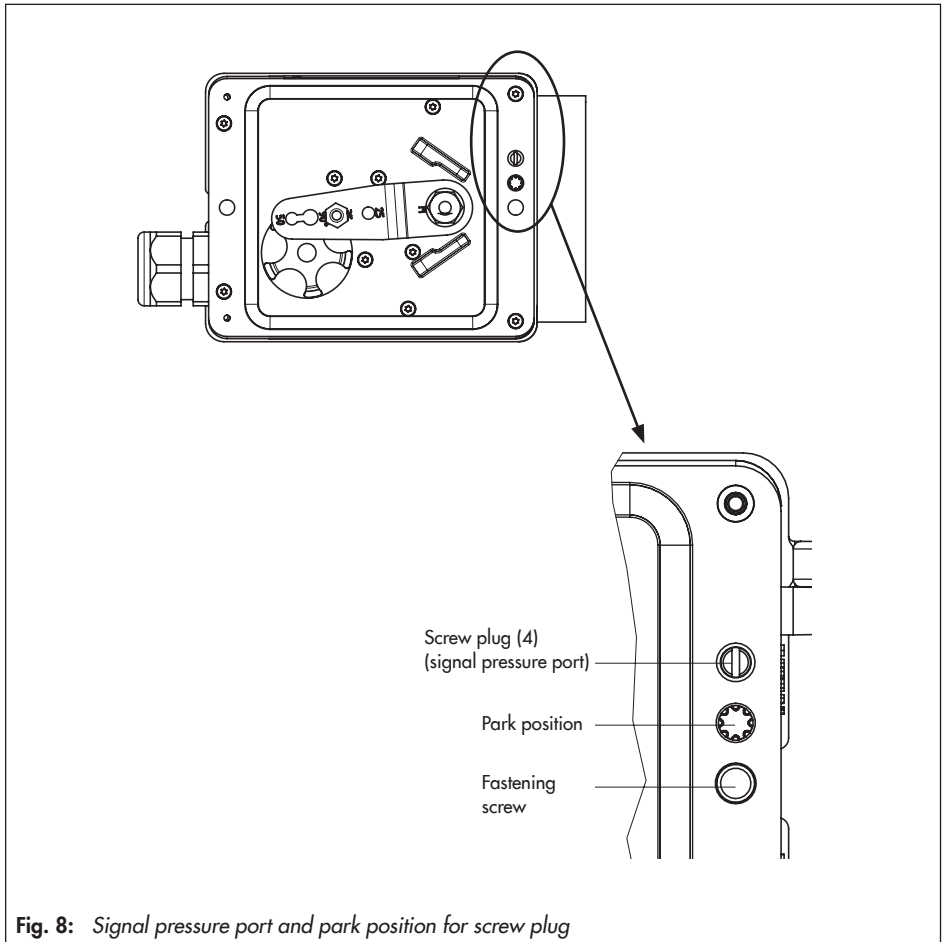

### 5.2.2 Type 3277 Actuator

- ➔ Required mounting parts and accessories: Table 4 on page 16.
- ➔ Observe travel tables on page 20.

#### Actuators with 175 to 750 cm<sup>2</sup> effective areas

The positioner can be mounted either on the left or right side of the yoke. The signal pressure is routed to the actuator over the connection block (12), for actuators with fail-safe action "actuator stem extends" internally through a hole in the valve yoke and for "actuator stem retracts" through an external pipe.

Place follower clamp (3) on the actuator stem, align it and screw tight so that the mounting screw is located in the groove of the actuator stem.

1. For actuators 175 and 350 cm<sup>2</sup> with 15 mm travel, keep the pin (2) in pin position 35.

For actuators with 355 or 750 cm<sup>2</sup>, remove the pin (2) on M lever (1) on the back of the positioner from pin position 35, reposition it in the hole for pin position 50 and fasten tight.

2. Insert formed seal (15) in the groove of the positioner housing.
3. Place positioner on the actuator in such a manner that the pin (2) rests on top of the follower clamp (3).
4. While doing this, press on the ribbed area to lock the lever in the top position (see Fig. 5).

The lever (1) must rest on the follower clamp with spring force.

Fasten the positioner on the actuator using the two fixing screws.

5. Make sure that the tip of the gasket (16) projecting from the side of the connection block is positioned to match the actuator symbol for the actuator's fail-safe action "actuator stem extends" or "actuator stem retracts". If this is not the case, unscrew the three fastening screws and lift off the cover. Turn the gasket (16) by 180° and re-insert it.
6. Place the connection block (12) with the associated seals against the positioner and the actuator yoke and fasten using the screw (12.1).
7. For actuators with fail-safe action "actuator stem retracts", additionally remove the stopper (12.2) and mount the external signal pressure pipe.
8. Mount cover (11) on the other side. Make sure that the vent plug is located at the bottom when the control valve is installed to allow any condensed water that collects to drain off (see Fig. 7 on page 30).



Type 3277 Actuator with Type 3725  
Positioner (direct attachment)

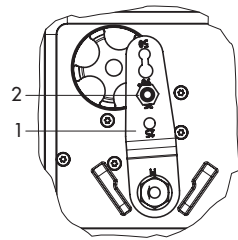
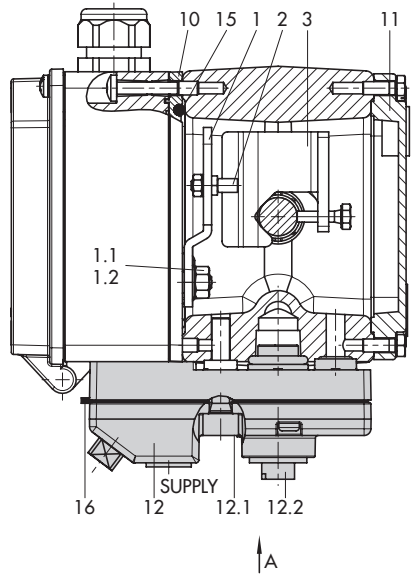

- 1 M lever
- 1.1 Nut
- 1.2 Disk spring
- 2 Follower pin
- 3 Follower clamp
- 11 Cover
- 12 Connection block
- 12.1 Screw
- 12.2 Stopper or connection for external piping
- 15 Formed seal
- 16 Gasket

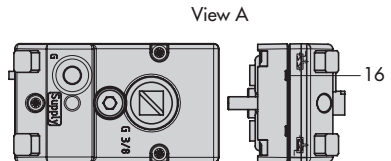

Fig. 9: Direct attachment · Signal pressure connection for Type 3277 Actuator with 240 to 750 cm<sup>2</sup>

### 5.3 Attachment according to IEC 60534-6

The positioner is attached to the control valve using a NAMUR bracket (10).

- Required mounting parts and accessories: Table 6 on page 18.
  - Observe travel tables on page 20.
1. Screw the two bolts (14) to the bracket (9.1) of the stem connector (9), place the follower plate (3) on top and use the screws (14.1) for fastening.
  2. Fasten the NAMUR bracket (10) to the control valve.
    - For valve with NAMUR rib: Fasten the NAMUR bracket (10) using the M8 screw (11) and toothed lock washer directly to the yoke hole.
    - For valves with rod-type yoke: Place the two U-bolts (16) around the stem. Position the NAMUR bracket (10) and fasten it using the nuts, washers and toothed lock washers.
  3. Align the NAMUR bracket (10) so that its mounting holes are approximately in line to the middle of the travel scale indicator (15) (the slot of the follower plate must be centrally aligned with the NAMUR bracket at mid valve travel).
  4. Mount connecting plate (6) or pressure gauge bracket (7) with pressure gauges (8) on the positioner, making sure the two seals (6.1) are seated properly.
  5. Place positioner on the NAMUR bracket in such a manner that the pin (2) rests in

the slot of the follower plate (3). Adjust the lever (1) correspondingly.

Fasten the positioner to the NAMUR bracket using its two mounting screws.

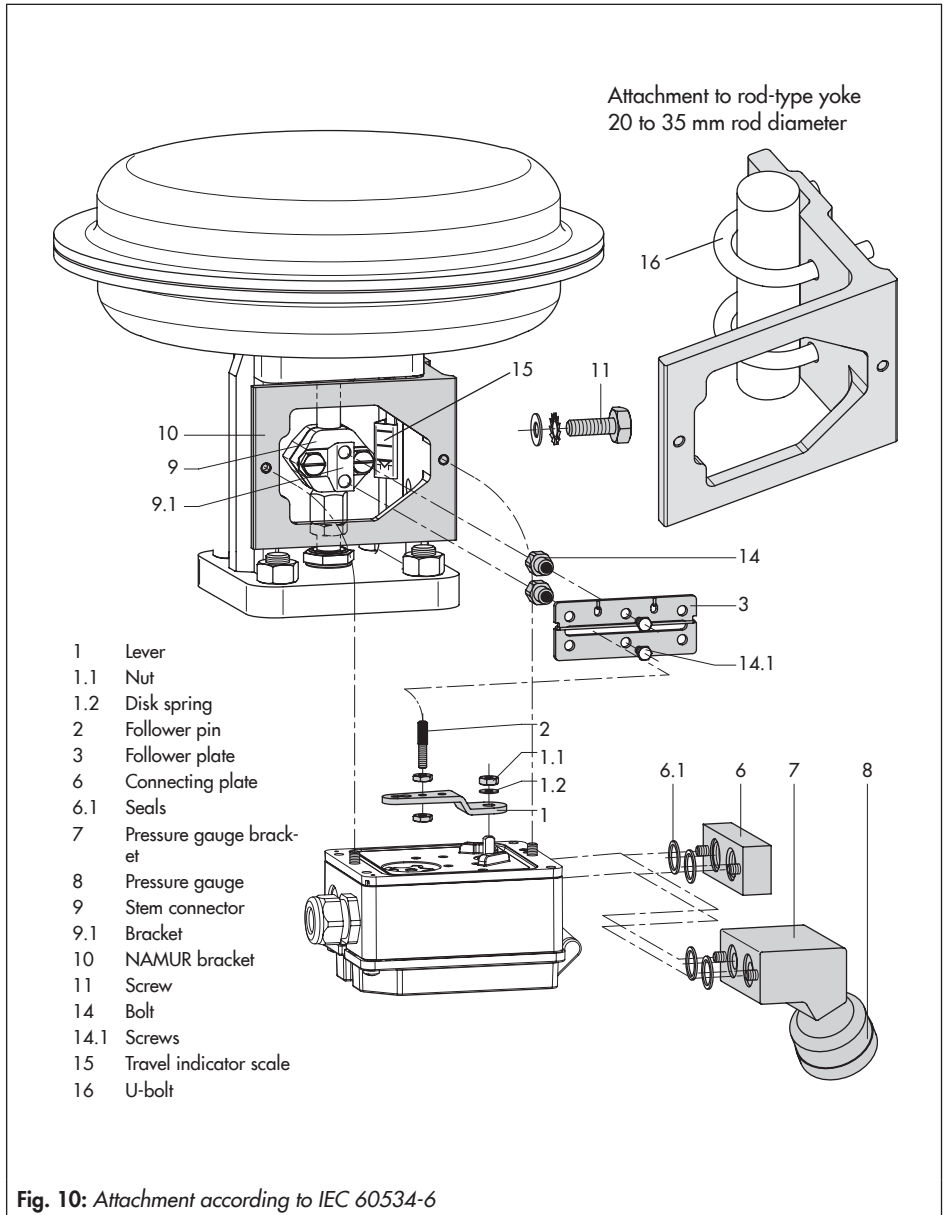

### 5.4 Attachment to Type 3372 Actuator (V2001)

The Type 3725 Positioner is already included in the scope of delivery for Series V2001 Valves (Fig. 11).

The attachment is briefly described below to allow conversion work to be performed.

#### **Actuator with 120/350 cm<sup>2</sup>, stem extends**

The signal pressure is routed through the corresponding port in the support element to the actuator diaphragm.

→ Thread the screw plug on the positioner into the hole below (park position) (see Fig. 8 on page 31).

#### **Actuator with 120/350 cm<sup>2</sup>, stem retracts**

The signal pressure is routed through piping at the side of the support element to the actuator diaphragm.

#### **Attachment including solenoid valve**

The signal pressure is routed from the output port of the positioner to the solenoid valve and through a corresponding hole in the support element to the actuator diaphragm.



**Type 3372 Actuator,  
version with 120 cm<sup>2</sup>**



**Type 3372 Actuator,  
version with 350 cm<sup>2</sup>**

**Fig. 11: Mounting on Type 3372 Actuator**

### 5.5 Attachment to rotary actuators

The positioner is mounted to the rotary actuator using a mounting bracket.

- ➔ Required mounting parts and accessories: Table 7 on page 18.
- ➔ Before attaching the positioner onto the SAMSON Type 3278 Rotary Actuator (160 cm<sup>2</sup>) or VETEC Type S160 Actuator, first mount the adapter (13) to the free end of the shaft end using four screws (10, 1).

1. Place follower clamp (3) on the slotted actuator shaft or adapter (13).
2. Place coupling wheel (4) with flat side facing the actuator on the follower clamp (3). Refer to Fig. 12 to align slot so that it matches the direction of rotation when the valve is in its closed position.
3. Fasten the coupling wheel (4) and follower clamp (3) tightly onto the actuator shaft using screw (4.1) and disk spring (4.2).
4. Mount connecting plate (6) or pressure gauge bracket (7) with pressure gauges (8) on the positioner, making sure the two seals are seated properly.
5. Fasten the mounting bracket (10) to the actuator using four screws (10.1).
6. Unscrew the standard follower pin (2) from the positioner's M lever (1). Use the metal follower pin (Ø 5 mm) included in the mounting kit and screw tight into the hole for pin position 90°.

7. Place positioner on the mounting bracket (10) and fasten tight. Taking the actuator's direction of rotation into account, adjust lever (1) so that it engages in the slot of the coupling wheel (4) with its lower pin (Fig. 13).
- ➔ The lever (1) must be parallel to the long side of the positioner when the actuator is at half its angle of rotation.
8. Stick the scale plate on the coupling wheel (4) so that the arrow tip indicates the closed position and it can be easily read when the valve is installed.

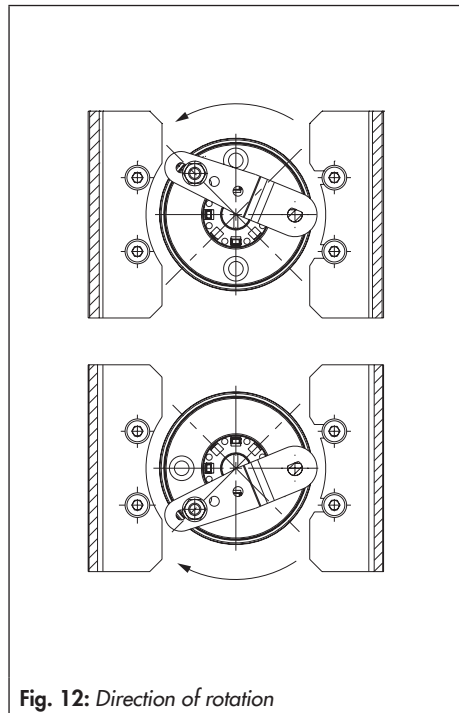

Fig. 12: Direction of rotation

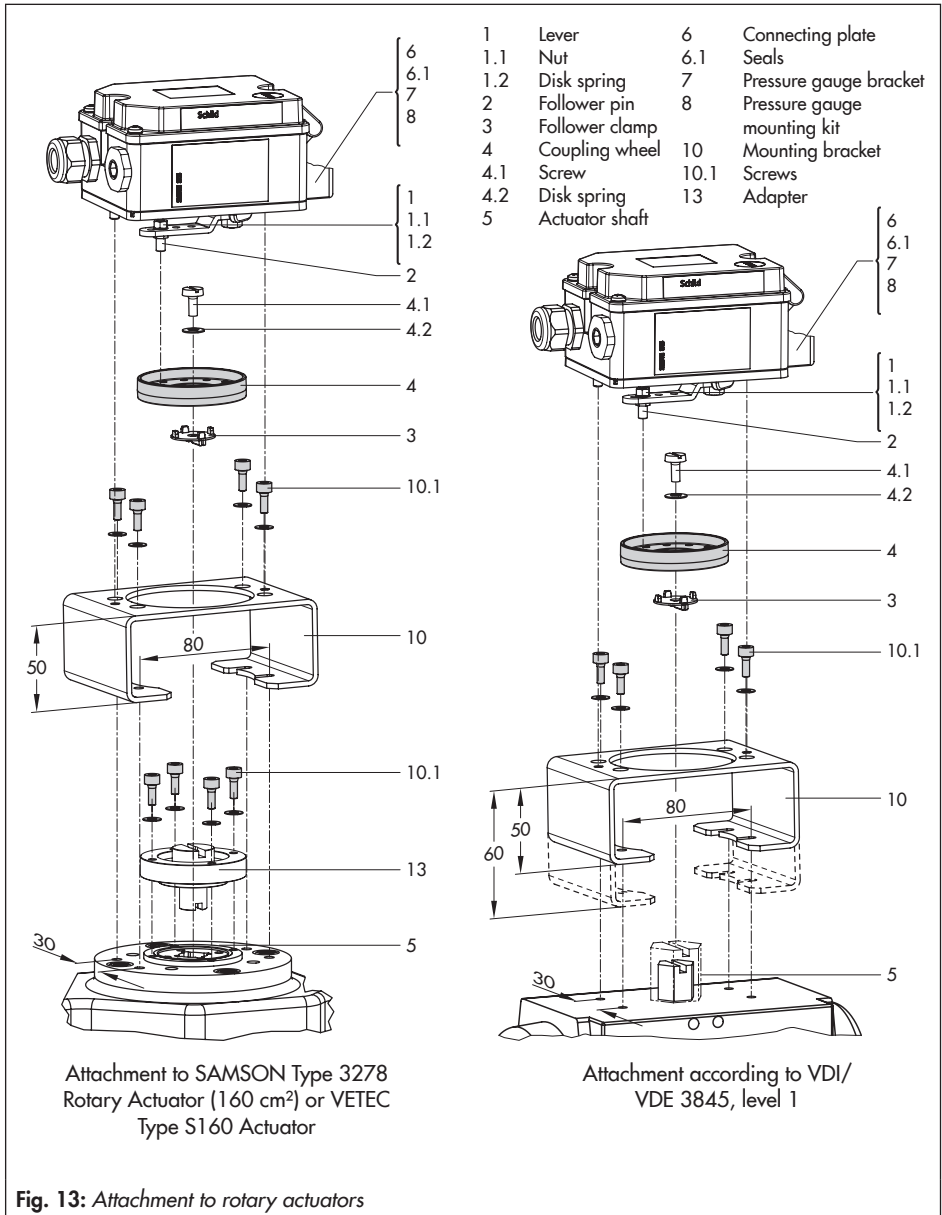

Fig. 13: Attachment to rotary actuators

### 5.5.1 Heavy-duty version

➔ Required mounting parts and accessories: Table 7 on page 18.

Prepare actuator and mount possibly required adapter supplied by the actuator manufacturer.

1. Mount the housing (10) onto the rotary actuator. In case of VDI/VDE attachment, place spacers (11) underneath, if necessary.
2. For **SAMSON Type 3278** and **VETEC S160 Rotary Actuators**, screw the adapter (5) onto the free end of the shaft or place adapter (5.1) onto the shaft of the **VETEC R Actuator**. Place adapter (3) onto **Type 3278, VETEC S160 and VETEC R Actuators**. For **VDI/VDE version**, this step depends on the actuator size.
3. Stick adhesive label (4.3) onto the coupling in such a manner that the yellow part of the sticker is visible in the window of the housing when the valve is OPEN. Adhesive labels with explanatory symbols are enclosed and can be stuck on the enclosure, if required.
4. Fasten coupling wheel (4) on the slotted actuator shaft or adapter (3) using screw (4.1) and disk spring (4.2).
5. Unscrew the standard follower pin (2) from the positioner's M lever (1). Attach the follower pin (Ø5 mm) included in the mounting kit to pin position 90°.
6. Mount connecting plate (6) for required G ¼ connecting thread or pressure gauge bracket (7) with pressure gauges on the positioner, making sure the two

seals (6.1) are seated properly. Double-acting springless rotary actuators require the use of a reversing amplifier on the connection side of the positioner housing (refer to section 5.5.2).

7. For actuators with a volume of less than 300 cm<sup>3</sup>, fit the restriction (order no. 1400-6964) into the signal pressure output of the positioner (or the output of the pressure gauge bracket or connecting plate).
8. Fasten the positioner onto the adapter plate (12).
9. Place the positioner together with the adapter plate on the housing (10) and screw it tight. Taking the actuator's direction of rotation into account, adjust lever (1) so that it engages in the correct slot with its follower pin (Fig. 14).

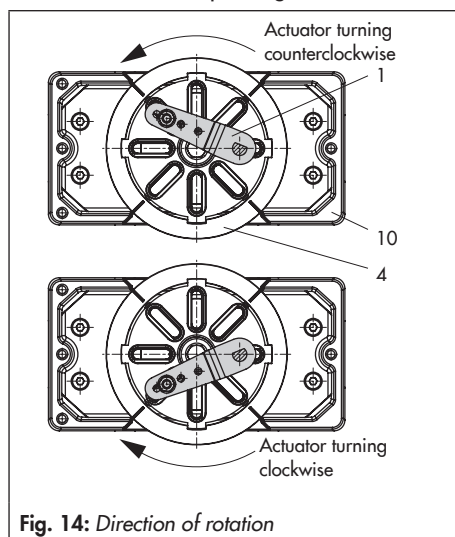

Fig. 14: Direction of rotation



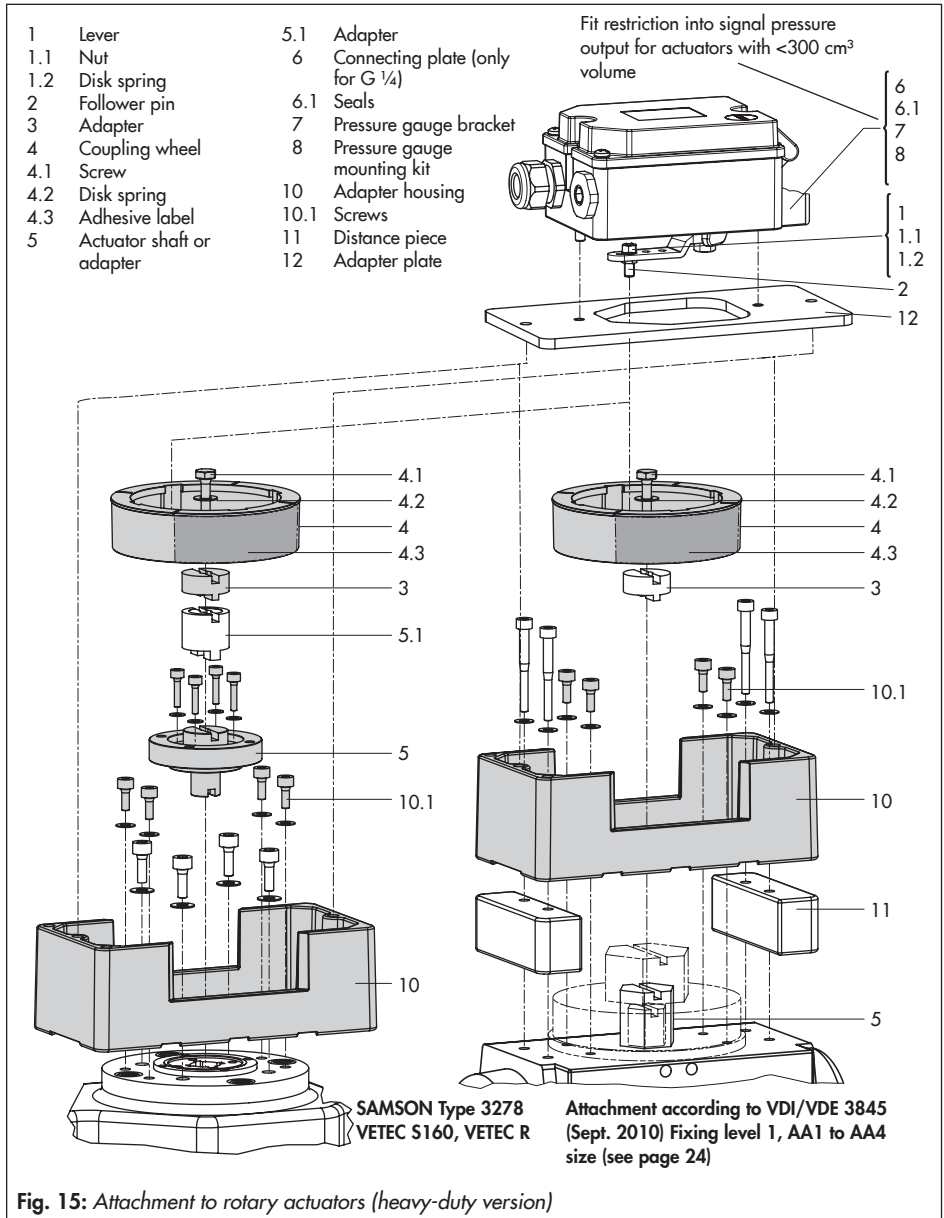

Fig. 15: Attachment to rotary actuators (heavy-duty version)

### 5.5.2 Mounting the Type 3710 Reversing Amplifier

When a Type 3710 Reversing Amplifier is used, a connecting plate is placed between the positioner and reversing amplifier. The reversing amplifier is fastened together with the connecting plate to the positioner using screws (Fig. 16).

#### **i** Note

*The screws supplied with the connecting plate have a TORX PLUS® profile (size 25 IP) and must be tightened using a suitable tool.*

Details on the Type 3710 Reversing Amplifier: Mounting and Operating Instructions

► EB 8392

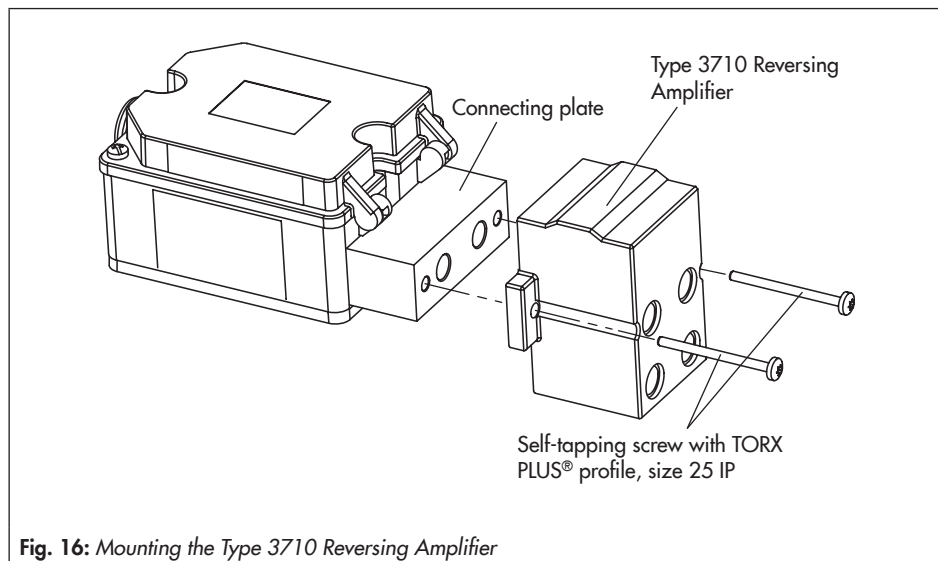

Fig. 16: Mounting the Type 3710 Reversing Amplifier

## 5.6 Pneumatic connections

### ⚠ WARNING

Risk of injury by possible movement of the actuator stem after connecting the signal pressure.  
Do not touch or block the actuator stem.

### ⓘ NOTICE

Incorrect connection of the supply air will damage the positioner and will lead to malfunction.

- Screw the screw fittings into the connecting plate, pressure gauge mounting block or connection block from the accessories.
- Keep the length of the line as short as possible to avoid delays in control signal transmission.

The pneumatic connections are optionally designed as a bore with ¼ NPT or G ¼ thread. The customary fittings for metal and copper pipes or plastic hoses can be used.

### ⓘ NOTICE

Risk of malfunction due to failure to comply with required air quality.  
Only use supply air that is dry and free of oil and dust.  
Read the maintenance instructions for upstream pressure reducing stations.  
Blow through all air pipes and hoses thoroughly before connecting them.

## 5.7 Connecting the supply air

### ⓘ NOTICE

Risk of malfunction due to incorrect sequence of mounting, installation, and start-up.  
Keep the following sequence.

1. Remove the protective caps from the pneumatic connections.
2. Mount the positioner on the valve.
3. Connect the supply air.
4. Connect the electrical power.
5. Perform the start-up settings.

### 5.7.1 Signal pressure connection

The signal pressure connection depends on how the positioner is mounted onto the actuator:

#### Type 3277 Actuator

- ➔ The signal pressure connection is fixed when the positioner is directly attached to the Type 3277 Actuator.

## Mounting and start-up

### Attachment according to IEC 60534-6 (NAMUR)

- For attachment according to IEC 60534-6 (NAMUR), the signal pressure can be routed to either the top or bottom diaphragm chamber of the actuator, depending on the actuator's fail-safe action "actuator stem extends" or "actuator stem retracts".

### Rotary actuators (heavy-duty version)

- For rotary actuators, the manufacturer's specifications for connection apply.



#### Tip

To monitor the supply air and signal pressure, we recommend mounting pressure gauges (see accessories in section Table 7).

### Mounting the pressure gauges:

- See sections 5.3 and Fig. 10

## 5.7.2 Supply pressure

The required supply air pressure depends on the bench range and the actuator's direction of action (fail-safe action). The bench range is written on the nameplate either as the spring range or signal pressure range. The operating direction is marked **FA** or **FE**, or by a symbol.

### Fail-close or ATO (air to open):

Actuator stem extends

### Fail-open or ATC (air to close):

Actuator stem retracts

### Supply pressure for fail-close valves (for globe and angle valves):

- Required supply pressure = Upper bench range value + 0.2 bar, minimum 1.4 bar.

### Supply pressure for fail-open valves (for globe and angle valves):

- For tight-closing valves, the maximum signal pressure  $p_{st_{max}}$  is roughly estimated as follows:

$$p_{st_{max}} = F + \frac{d^2 \cdot \pi \cdot \Delta p}{4 \cdot A} \text{ [bar]}$$

$d$  = Seat diameter [cm]

$\Delta p$  = Differential pressure across the valve [bar]

$A$  = Actuator area [cm<sup>2</sup>]

$F$  = Upper bench range value [bar]

### If there are no specifications, calculate as follows:

- Required supply pressure = Upper bench range value + 1 bar

#### **i** Note

The signal pressure at the output (38) of the positioner can be restricted to approx. 2.3 bar by setting P9 parameter code to ON.

## 5.8 Electrical connections

### **⚠ DANGER**

#### **Risk of the formation of an explosive atmosphere.**

For installation in hazardous areas, observe the relevant standards that apply in the country of use.

Standard applicable in Germany: EN 60079-14: 2008 (VDE 0165, Part 1) Explosive Atmospheres – Electrical Installations Design, Selection and Erection.

### **⚠ WARNING**

Incorrect electrical connection will render the explosion protection unsafe.

- Adhere to the terminal assignment.
- Do not undo the enameled screws in or on the housing.
- Do not exceed the maximum permissible values specified in the EC type examination certificates when interconnecting intrinsically safe electrical equipment ( $U_i$  or  $U_o$ ,  $I_i$  or  $I_o$ ,  $P_i$  or  $P_o$ ,  $C_i$  or  $C_o$  and  $L_i$  or  $L_o$ ).

#### Selecting cables and wires

→ **Observe clause 12 of EN 60079-14 (VDE 0165, Part 1) for installation of the intrinsically safe circuits.**

- Clause 12.2.2.7 applies when running multi-core cables and wires with more than one intrinsically safe circuit.
- **Radial thickness of the insulation** of a conductor for common insulating materials (e.g. polyethylene): **minimum 0.2 mm.**
- **Diameter of an individual wire** in a fine-stranded conductor: **minimum 0.1 mm.**
- Strip **8 mm** insulation off the wire ends.
- Protect the conductor ends against splicing, e.g. by using wire-end ferrules.

→ Cable glands available:  
See Table 8 on page 19

### Equipment for use in zone 2/zone 22

In equipment operated according to type of protection Ex nA II (non-sparking equipment) according to EN 60079-15: 2003:

- Circuits may be connected, interrupted, or switched while energized only during installation, maintenance, or repair.

Equipment connected to energy-limited circuits with type of protection Ex nL (energy-limited equipment) according to EN 60079-15: 2003:

- Equipment may be switched under normal operating conditions.

The maximum permissible values specified in the statement of conformity and its addenda apply when interconnecting the equipment with energy-limited circuits in type of protection Ex nL IIC.

### 5.8.1 Electric power supply

- Only use a current source and never a voltage source!
- Keep the reference variable within the static destruction limit of  $\pm 33$  V.

### 5.8.2 Cable entry

The M20x1.5 cable gland is designed for a clamping range of 6 to 12 mm.

The cage clamp terminals hold wire cross-sections of 0.2 to 1.5 mm<sup>2</sup>.

- To unlock the cage clamp terminals: place a slotted screwdriver on the plastic part (Fig. 17) and lightly push it into the terminal block.
- Insert or remove the wire **without force**.

### 5.8.3 Connecting the electrical power

---

#### ! NOTICE

*Risk of malfunction due to incorrect sequence of mounting, installation, and start-up. Keep the following sequence.*

1. *Remove the protective caps from the pneumatic connections.*
2. *Mount the positioner on the valve.*
3. *Connect the supply air.*
4. *Connect the electrical power.*
5. *Perform the start-up settings.*

- 
- Connect the electrical power (mA signal) as shown in Fig. 17.

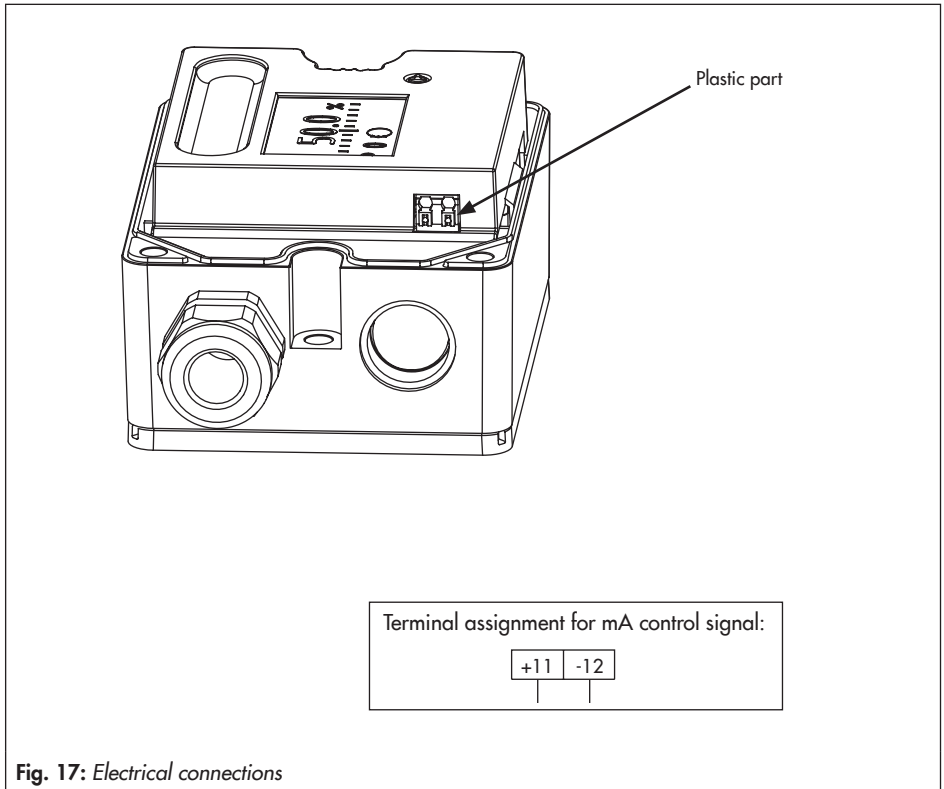

Fig. 17: Electrical connections

# 6 Operation

## 6.1 Operating controls

Three capacitive keys are used to operate the positioner and allow the user to navigate within the menu on the display (Fig. 18). Additionally, the volume restriction allows the air output capacity to be adapted to the size of the actuator.

### 6.1.1 Capacitive keys

**△**: Up

**\***: Confirm

**▽**: Down

Touch **△** or **▽** key to select a parameter code (**P0** to **P20**). Then touch **\*** key to confirm the selected code.

To save changes to parameters in a non-volatile memory, proceed as follows:

- After changing parameters, press **△** or **▽** to change to Code **P0** or
- wait three minutes until the display returns automatically to **P0**.

---

#### **i** Note

- The  icon on the display indicates that the changed parameter settings have not yet been saved in the non-volatile memory.
  - The selected parameter code remains active until you change the setting or exit the parameter code.
  - After changing settings in **P2**, **P4** and **P8** parameter codes, the positioner must be re-initialized.
- 

### 6.1.2 Volume restriction Q

The volume restriction serves to adapt the air output capacity to the size of the actuator. Two fixed settings are possible (refer to section 7.3).



### 6.1.3 Display

Icons which are assigned to certain codes and functions are indicated on the display (Fig. 18). The bar elements indicate the system deviation that depends on the sign (+/-) and the value. One bar element appears per 1 % system deviation.

If the positioner has not yet been initialized, the lever position in degrees in relation to the mid-axis is indicated. One bar element corresponds to approximately a 7° angle of rotation.

If the fault indication icon  is displayed, press  or  until **ERR** is displayed to view the **E0** to **E15** error codes (see section 9.2).

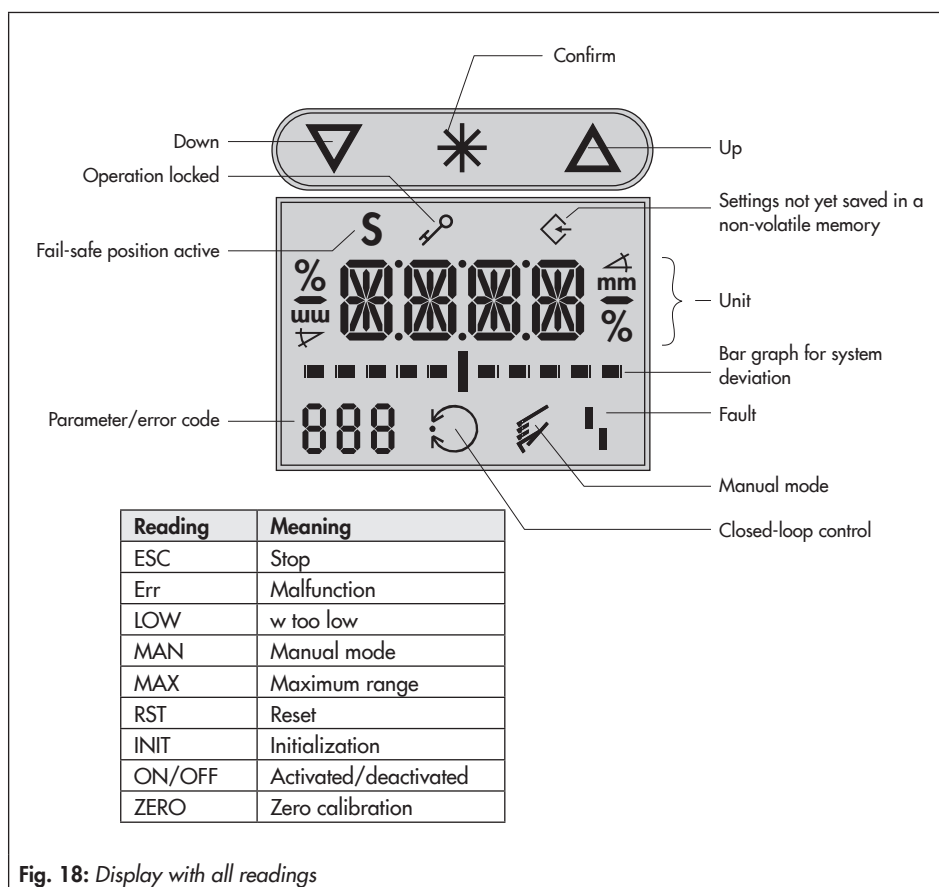

Fig. 18: Display with all readings

# 7 Operating the positioner

Before start-up, mount the positioner following the sequence described in section 5. Apply the electric reference variable to start up the positioner. Refer to section 5.8.3.

### **i** Note

- **LOW** on the display indicates that the reference variable is lower than 3.8 mA.
- The positioner is ready for operation with its default settings for most applications.
- After connecting the electrical signal, the positioner performs a calibration of the capacitive keys which takes approx. three seconds. During this time, do not touch the key panel. Otherwise, the keys will not work properly. Disconnect and reconnect the electrical signal to restart the calibration of keys.

### Reading after connecting the power supply

Reading when the positioner has **not** yet been initialized

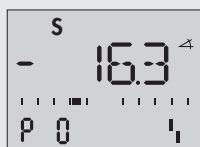

Code **P0** is displayed. The  fault indication icon and **S** (fail-safe position) appear on the display.

The reading indicates the lever position in degrees in relation to the mid-axis.

Reading when the positioner has been initialized:



Code **P0** is displayed. The positioner is in closed-loop operation indicated by the  closed-loop operation icon.

The indicated value corresponds to the control position in %.

Details on initialization of the positioner: section 7.8.

## 7.1 Adapting the display

The display reading direction can be rotated by 180°. If the displayed data appear upside down, proceed as follows:

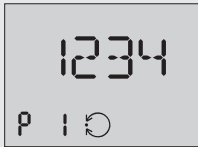

1. Touch  $\Delta$  or  $\nabla$  until Code **P1** appears.
2. Press  $*$  to confirm the selected code. **P1** blinks.
3. Touch  $\Delta$  or  $\nabla$  until the display is set in the desired direction.
4. Press  $*$  to confirm display direction.

## 7.2 Enabling configuration to change parameters

**Before** changing parameter settings in an initialized positioner, configuration must be enabled first by selecting Code **P19**:



**LOCK** and the key icon indicate that the configuration is locked. Deactivate locking as follows:

1. Touch  $\Delta$  or  $\nabla$  until Code **P19** appears.
2. Press  $*$  to confirm the selected code. **P19** blinks.
3. Touch  $\Delta$  or  $\nabla$  until **OPEN** is displayed.
4. Press  $*$  to enable configuration.

---

### **i** Note

If no settings are entered within three minutes, the enabled configuration function becomes invalid.

---

### 7.3 Adjusting the volume restriction Q

The volume restriction Q (see Fig. 19) serves to adapt the air output capacity to the size of the actuator:

Actuators with a **transit time**  $< 1$  s, e.g. linear actuators with an effective area smaller than 240 cm<sup>2</sup>, require a restricted air flow rate.

→ Setting to MIN

Actuators with a **transit time**  $\geq 1$  s do not require the air flow rate to be restricted.

→ Setting to MAX

**Additional points that apply concerning the volume restriction:**

→ Intermediate settings are not permitted.

→ Re-initialize positioner after changing the volume restriction setting.

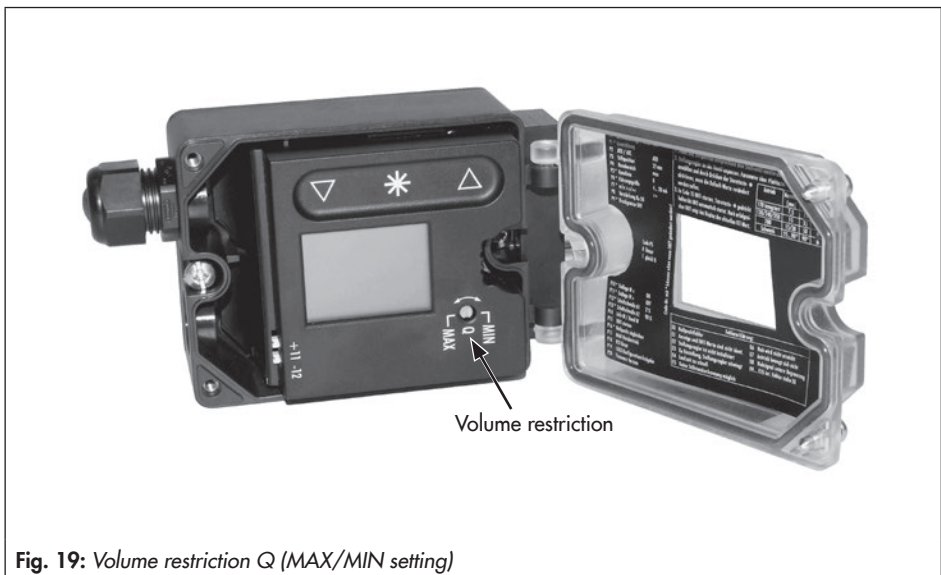

Fig. 19: Volume restriction Q (MAX/MIN setting)

## 7.4 Entering the air action

- ATO (air to open) applies to a valve opening as the signal pressure increases.
- ATC (air to close) applies to a valve closing as the signal pressure increases.

The signal pressure is the pneumatic pressure at the output of the positioner applied to the actuator.



Default air action: **ATO**

Change the air action (enable configuration as described in section 7.2):

1. Touch  $\Delta$  or  $\nabla$  until Code **P2** appears.
2. Press  $*$  to confirm selected code. **P2** blinks.
3. Touch  $\Delta$  or  $\nabla$  until the required air action appears.
4. Press  $*$  to confirm setting.

### **i** Note

The changed air action first becomes effective after the positioner has been re-initialized.

## 7.5 Entering the direction of action

The direction of action (**P7**) is set to increasing/increasing ( $\gg$ ) by default, i.e. when the positioner is initialized, **0** % is displayed when the valve is closed and **100** % when the valve is fully open. If necessary, the direction of action can be changed (enable configuration as described in section 7.2):



Changing the direction of action to increasing/decreasing:

1. Touch  $\Delta$  or  $\nabla$  until Code **P7** appears.
2. Press  $*$  to confirm selected code. **P7** blinks.
3. Touch  $\Delta$  or  $\nabla$  until  $\leftrightarrow$  appears.
4. Press  $*$  to confirm setting.

## Operating the positioner

The following correlation applies:

Valve	CLOSED	OPEN
Display	0 %	100 %
Direction of action increasing/increasing (>>)	4 mA	20 mA
Direction of action increasing/decreasing (<>)	20 mA	4 mA

### 7.6 Limiting the signal pressure

If the maximum actuator force is too high for the valve used, the signal pressure limit can be activated in Code **P9**. The pressure is then limited to approx. 2.3 bar.



*Activate the signal pressure limitation (enable configuration as described in section 7.2):*

1. Touch  $\Delta$  or  $\nabla$  until Code **P9** appears.
2. Press  $*$  to confirm selected code. **P9** blinks.
3. Touch  $\Delta$  or  $\nabla$  until **ON** appears.
4. Press  $*$  to confirm setting.

## 7.7 Setting other parameters

The following table lists all the parameter codes and their default settings. Proceed as described previously to change parameters.

More details concerning the parameter codes can be found in section 11.2.

Parameter codes [default settings]			
P0	Status indication	P10	End position w < [ON]
P1	Reading direction	P11	End position w > [OFF]
P2 <sup>1)</sup>	ATO/ATC [ATO]	P14	Display of reference variable w
P3 <sup>1)</sup>	Pin position [35]	P15	INIT Start initialization
P4 <sup>1)</sup>	Nominal range [MAX]	P16	ZERO Start zero calibration
P5	Characteristic [0]	P17	MAN Manual mode
P6	Reference variable [4 to 20 mA]	P18	RST Reset
P7	w/x direction of action [>>]	P19	Enable configuration
P8 <sup>1)</sup>	Gain Kp [50]	P20	Firmware version
P9	Pressure limitation 2.3 bar [OFF]		

<sup>1)</sup> Positioner needs to be re-initialized after changing the parameter setting

## 7.8 Initialization

During initialization the positioner adapts itself optimally to the friction conditions and the signal pressure required by the control valve.

### **⚠ WARNING**

*Risk of injury due to the actuator stem extending or retracting.  
Do not touch or block the actuator stem.*

### **ⓘ NOTICE**

*The process is disturbed by the movement of the actuator stem.  
Do not initialize the positioner while the process is running and only after isolating the plant by closing the shut-off valves.*

## Operating the positioner

The type and extent of self-adaptation depends on the preset parameters. **MAX** applies as the default setting for the nominal range (Code **P4**). During the initialization process, the positioner determines the total travel range or rotational range of the valve (from the CLOSED position to the opposite end position).

Alternatively, a different travel can be selected in Code **P4** (see code list in section 11.2).

### **i** Note

The travel set in Code **P4** is only limited during initialization. However, it might be exceeded in closed-loop control when the control signal is higher than 20 mA.

**Start initialization** (enable configuration as described in section 7.2).

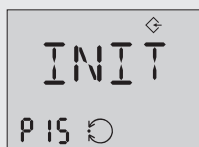

1. Touch  $\Delta$  or  $\nabla$  until Code **P15** appears.
2. Press  $*$  and hold for six seconds. 6...5...4...3...2...1 is counted down on the display.

The initialization starts and **INIT** blinks. The time required for the initialization procedure depends on the actuator transit time and can take a few minutes.



Initialization successfully completed. The positioner is in closed-loop operation indicated by the  $\odot$  closed-loop operation icon.

The indicated value corresponds to the control position in %.

Configuration is locked indicated by the key icon.

The fault indication icon  $\blacksquare$  appears when the initialization fails.

### 7.8.1 Canceling initialization

The initialization can be canceled:

1. During initialization touch  $*$ : **ESC** blinks on the display.
2. Press  $*$  to confirm: Initialization is canceled.

### **i** Note

This code must be confirmed by pressing  $*$ . Otherwise, the code remains active.



**Initial state 1:**

The positioner is **not** initialized.

The positioner goes to the fail-safe position after the initialization process has been canceled.

**Initial state 2:**

The positioner is initialized.

On canceling a new initialization process, the positioner returns to closed-loop operation.

The settings of the previous initialization are used.

A new initialization can be started directly afterwards.

## 7.9 Zero calibration

In case of inconsistencies in the closing position of the valve, e.g. with soft-seated plugs, it might be necessary to recalibrate zero over Code **P16** (enable configuration as described in section 7.2).

Start the zero calibration by activating Code **P16** as follows:



1. Touch  $\Delta$  or  $\nabla$  until Code **P16** appears.
2. Press  $*$  and hold for six seconds. 6...5...4...3...2...1 is counted down on the display.

Zero calibration starts, **ZERO** blinks on the display.

The time required for the initialization procedure depends on the actuator transit time and can take a few minutes.

The positioner moves the control valve to the CLOSED position and recalibrates the internal electric zero point.

When the zero calibration has been successfully completed, the positioner changes to closed-loop operation.

### 7.9.1 Canceling zero calibration

Zero calibration can be canceled:

1. During zero calibration touch **\***: **ESC** blinks on the display.
2. Press **\*** to confirm: Zero calibration is canceled.

---

**i Note**

*This code must be confirmed by pressing **\***. Otherwise, the code remains active.*

---

The positioner changes to closed-loop operation without performing a zero calibration. A new zero calibration can be started directly afterwards.

### 7.10 Manual mode

The valve position can be moved as follows using the **Manual mode** function:



*Enable configuration as described in section 7.2.*

1. Touch **Δ** or **∇** until Code **P17** appears.
2. Press **\*** and hold for six seconds. **6-5-4-3-2-1-** is counted down on the display and **P17** blinks.

*The manual set point is indicated on the display of an initialized positioner.*

*The lever position in degrees in relation to the longitudinal axis is indicated on the display of a positioner that has not been initialized.*

3. Touch **Δ** or **∇** to change the manual set point.

#### Initialized positioner

The manual mode starts using the last set point used in closed-loop operation, ensuring a bumpless changeover.

The bar elements on the display indicate the system deviation between the manual set point and set point used for closed-loop control while manually moving the valve in Code **P17**.

The manual set point is adjusted in steps of 0.1 %. You can move the valve controlled within its range.

### Positioner that has not been initialized

Touch  $\Delta$  or  $\nabla$  for a long time to move the valve manually.

The valve is only moved in one direction uncontrolled. The bar elements on the display indicate the change in direction.

Touch  $*$  to deactivate manual mode.

#### **i** Note

The Manual mode function can only be exited as described or by interrupting the electrical supply (cold start). The positioner does **not** automatically exit this function and return to the display showing the status indication.

## 7.11 Reset

A reset causes an initialization to be undone and all parameters settings are reset to the default settings (see code list in section 11.2).



Enable configuration as described in section 7.2.

1. Touch  $\Delta$  or  $\nabla$  until Code **P18** appears.
2. Press  $*$  and hold for six seconds. 6...5...4...3...2...1 is counted down on the display.

**RST** blinks while  $*$  is pressed. As soon as the key is released, the reset process is completed and the display returns to status indication (**P0**).

#### **i** Note

The **i** fault indication icon is displayed after a reset since the positioner needs to be re-initialized. The error code **E2** is also activated (see section 9.2).

## 8 Servicing

---

### **i** Note

The positioner was checked by SAMSON before it left the factory.

- The product warranty becomes void if service or repair work not described in these instructions is performed without prior agreement by SAMSON's After-sales Service department.
  - Only use original spare parts by SAMSON, which comply with the original specifications.
- 

The Type 3725 Positioner requires no maintenance. There are filters with a 100 µm mesh size in the pneumatic connections for supply and output which can be removed and cleaned, if required.

- ➔ Observe the maintenance instructions of any upstream supply air pressure reducing stations.

## 8.1 Cleaning the window in the cover

---

### **!** NOTICE

*Incorrect cleaning will damage the window. The window is made of Makrolon® and will be damaged when cleaned with abrasive cleaning agents or agents containing solvents.*

- Do not rub the window dry.
  - Do not use any cleaning agents containing chlorine or alcohol or abrasive cleaning agents.
  - Use a non-abrasive, soft cloth for cleaning.
- 

### **💡** Tip

*If the plant operation does not allow the specified conditions to be met, renew the cover (order no. 1992-6367) at regular intervals.*

---

## 8.2 Preparation for return shipment

Defective positioners can be returned to SAMSON for repair.

Proceed as follows to return devices to SAMSON:

1. Put the control valve out of operation.  
See associated valve documentation.
2. Remove the positioner (see section 10.2).
3. Continue as described on our website at  
▶ [www.samsongroup.com](http://www.samsongroup.com) > Service & Support > After-sales Service > Returning goods.

## 9 Malfunctions

In case of a fault, the fault indication icon  is displayed. Switch past Code **P0** or **P20** to display the respective error code **E0** to **E15** together with **ERR** appear on the display. Refer to the error code list in section 9.2 for the cause of the errors and the recommended action.

### Example:

If, for instance, a travel has been entered in Code **P4** (nominal range) which is larger than the maximum valve travel possible, the initialization process would be interrupted (**E2** error code) because the rated travel would not have been reached (**E6** error code). The valve moves to the fail-safe position (**S** indicated on the display).

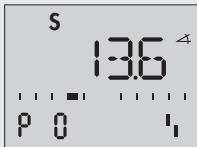

*Display of the fault indication:*

- Fault indication icon  appears.
- Valve moves to fail-safe position (**S** indicated on the display).

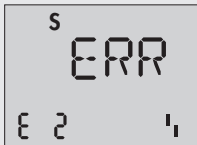

*E2 error code: Initialization canceled.*

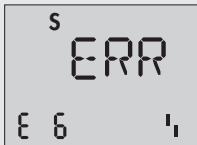

*E6 error code: Rated travel not achieved.*

The nominal range (Code P4) must be changed and the positioner re-initialized to remedy this problem.

### 9.1 Resetting error codes

The E0 and E8 error codes can be reset as follows:

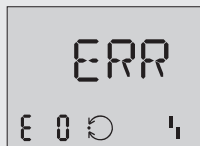

1. Touch  $\blacktriangle$  or  $\blacktriangledown$  to select the error code.

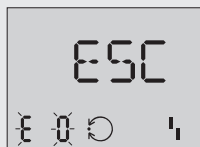

2. Touch  $*$  to confirm the error code. **ESC** is displayed and the error code blinks.

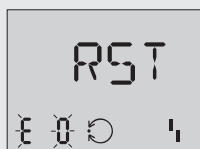

3. Touch  $\blacktriangle$  or  $\blacktriangledown$  until **RST** appears.

4. Press  $*$  to reset the error.

The reset procedure can be canceled by touching  $*$  when **ESC** appears.



## 9.2 Error codes

The errors listed in the following table are assigned to error classes:

**Error class 1:** No operation possible

**Error class 2:** Manual operation only possible

**Error class 3:** Manual operation and closed-loop control possible

Contact SAMSON's After-sales Service department for malfunctions not listed in the table (see section 11.1).

Code	Description		Class
E0	<b>Zero error</b> (operational error)	Only with tight-closing function <b>P10</b> (end position $w < \text{set to ON}$ ). The zero point has shifted by more than 5 % compared to initialization. The error may arise when the valve seat trim is worn.	3
	Recommended action	Check valve and positioner attachment. If the positioner is mounted correctly, perform a zero calibration over Code <b>P16</b> (see section 7.9). <b>Error code can be reset (see section 9.1).</b>	
E1	<b>Displayed and INIT values are not identical</b> (operational error)	Adjusted and displayed valves are not identical to the INIT values as the parameters were changed after initialization.	3
	Recommended action	Reset parameters or perform initialization.	
E2	<b>Positioner has not been initialized</b>	Malfunction or parameter change requiring the positioner to be re-initialized.	2
	Recommended action	Set parameters and initialize the positioner over Code <b>P15</b> .	
E3	<b>K<sub>p</sub> setting</b> (initialization error)	Positioner hunts. Volume restriction set incorrectly, too much gain.	2
	Recommended action	Check the volume restriction setting as described in section 7.3. Limit gain K <sub>p</sub> in Code <b>P8</b> . Re-initialize the positioner.	
E4	<b>Transit time too short</b> (initialization error)	The transit times of the actuator determined during initialization are so short (below 0.5 second) that optimal positioner tuning is not possible.	2
	Recommended action	Check the volume restriction setting as described in section 7.3. Re-initialize the positioner.	



E5	<b>Standstill detection is not possible</b> (initialization error)	Supply pressure varies. Mounting incorrect.	2
	Recommended action	Check supply air and positioner mounting. Re-initialize the positioner.	
E6	<b>Travel is not achieved during initialization</b> (initialization error)	Supply pressure is too low, actuator leaks, incorrect travel adjusted or pressure limit function activated.  When MAX is selected for <b>P4</b> code (nominal range): the measuring span of the lever is too small (incorrect lever, incorrect pin position). Initialization is canceled when the angle of rotation of the positioner shaft is smaller than 11°.	2
	Recommended action	Check supply air, positioner mounting, lever, pin position, and setting. Re-initialize the positioner.	
E7	<b>Actuator does not move</b> (initialization error)	No supply air, mounting blocked.	2
	Recommended action	Check supply air, positioner mounting and mA input signal. Re-initialize the positioner.	
E8	<b>Travel signal at lower/upper limit</b>	Wrong pin position, wrong lever, wrong attachment direction when NAMUR attachment is used.	1
	Recommended action	Reset error code (see section 9.1). Check positioner mounting and re-initialize the positioner.	
E9 to E15	<b>Device error (internal)</b>	Return positioner to SAMSON AG for repair.	1/3

### 9.3 Emergency action

Upon failure of the air supply or electric signal, the positioner vents the actuator, causing valve to move to the fail-safe position determined by the actuator.

The plant operator is responsible for emergency action to be taken in the plant.



*Emergency action in the event of valve failure is described in the associated valve documentation.*

---

### 10 Decommissioning and disassembly

---

#### **⚠ DANGER**

***Risk of fatal injury due to ineffective explosion protection.***

*The explosion protection becomes ineffective when the positioner cover is opened.*

*The following regulations apply to installation in hazardous areas: EN 60079-14 (VDE 0165, Part 1).*

---

#### **ⓘ NOTICE**

*The process is disturbed by interrupting closed-loop control.*

*Do not mount or service the positioner while the process is running and only after isolating the plant by closing the shut-off valves.*

---

### 10.1 Decommissioning

To decommission the positioner before removing it, proceed as follows:

1. Disconnect and lock the air supply and signal pressure.
2. Open the positioner cover and disconnect the wires for the control signal.

### 10.2 Removing the positioner

1. Disconnect the wires for the control signal from the positioner.
2. Disconnect the lines for supply air and signal pressure (not required for direct attachment using a connection block).
3. To remove the positioner, loosen the three fastening screws on the positioner.

### 10.3 Disposal

- Observe local, national, and international refuse regulations.
- Do not dispose of components, lubricants, and hazardous substances together with your other household waste.

## 11 Annex

### 11.1 After-sales service

Contact SAMSON's After-sales Service department for support concerning service or repair work or when malfunctions or defects arise.

#### **E-mail**

You can reach the After-sales Service Department at [aftersaleservice@samson](mailto:aftersaleservice@samson).

#### **Addresses of SAMSON AG and its subsidiaries**

The addresses of SAMSON AG, its subsidiaries, representatives, and service facilities worldwide can be found on the SAMSON website, in all SAMSON product catalogs or on the back of these Mounting and Operating Instructions.

#### **Required specifications**

Please submit the following details:

- Order number and position number in the order
- Type, serial number, firmware version, device version

## 11.2 Code list

### 11.2.1 Parameter codes

Code	Display, values [default setting]	Description
<b>Note:</b> Codes marked by an asterisk (*) indicate that the positioner needs to be re-initialized afterwards		
P0	<b>Status reading with basic information</b>	The reading indicates the valve position or angle of rotation in % when the positioner is initialized. On touching * when the positioner is not initialized, the position of the lever in relation to the mid-axis is displayed.
P1	<b>Reading direction</b>	The reading direction of the display is turned by 180°.
P2*	<b>ATO/ATC</b> [ATO]	Parameter to adapt the positioner to how the valve functions: ATO: Air to open (valve CLOSED in fail-safe position), ATC: Air to close (valve OPEN in fail-safe position)
P3*	<b>Pin position</b> 17/25/[35]/50/90°	Insert follower pin in the proper position depending on the valve travel/opening angle (select according to travel tables on page 20).
P4*	<b>Nominal range [MAX]</b> Values with default setting [35]: e.g. 7.5/8.92/10.6/12.6/ 15.0/17.8/21.2 mm	<b>Firmware 1.03 and lower:</b> The possible adjustment range can be selected in stages depending on the selected pin position: <b>25</b> From 5.3 to 15.0 mm <b>35</b> From 7.5 to 21.2 mm <b>50</b> From 10.6 to 30.0 mm  For <b>90°</b> : Maximum range only, if <b>P3</b> = 90° <b>MAX</b> : Maximum possible travel
	<b>Nominal range [MAX]</b>	<b>Firmware 1.10 and higher:</b> The possible adjustment range can be selected in steps of 0.5 mm depending on the selected pin position: <b>25</b> From 5.0 to 16.0 mm, alternatively <b>MAX</b> (up to 25.0 mm) <b>35</b> From 7.0 to 22.0 mm, alternatively <b>MAX</b> (up to 35.0 mm) <b>50</b> From 10.0 to 32.0 mm, alternatively <b>MAX</b> (up to 50.0 mm)  For <b>90°</b> : Maximum range only, if <b>P3</b> = 90° <b>MAX</b> : Maximum possible travel

<b>P5</b>	<b>Characteristic</b> 0 to 8 [0]	Select characteristic: 0, 1, 2 for globe valves, 0 to 8 with rotary actuators (P3 = 90°) 0 Linear 1 Equal percentage 2 Reverse equal percentage 3 SAMSON butterfly valve, linear 4 SAMSON butterfly valve, equal percentage 5 VETEC rotary plug valve, linear 6 VETEC rotary plug valve, equal percentage 7 Segmented ball valve, linear 8 Segmented ball valve, equal percentage
<b>P6</b>	<b>Reference variable</b> [4 to 20 mA] SRLO/SRHI	For split-range operation: <b>SRLO</b> : low range 4 to 11.9 mA <b>SRHI</b> : high range 12.1 to 20 mA
<b>P7</b>	<b>w/x</b> [>>]/<>	Direction of action of the reference variable w to the travel/rotational angle x (increasing/increasing or increasing/decreasing)
<b>P8*</b>	<b>Gain K<sub>p</sub></b> 30/[50]	On initializing the positioner, the gain is set to the selected value. If the positioner hunts, the K <sub>p</sub> value can be reduced.
<b>P9</b>	<b>Pressure limitation</b> ON/[OFF]	The signal pressure can take on the same pressure as the supply air at the maximum [OFF] or, in the case that the maximum actuator force can damage the valve, the pressure is limited to approx. 2.3 bar.
<b>P10</b>	<b>End position w &lt;</b> [ON]/OFF	Lower tight-closing function: If <b>w</b> reaches up to 1 % towards the final value that causes the valve to close, the actuator is immediately completely vented (with <b>ATO</b> - air to open) or filled with air (with <b>ATC</b> - air to close).
<b>P11</b>	<b>End position w &gt;</b> ON/[OFF]	Upper tight-closing function: If <b>w</b> reaches up to 99 % towards the final value that causes the valve to open, the actuator is immediately completely filled with air (with <b>ATO</b> - air to open) or vented (with <b>ATC</b> - air to close).
<b>P14</b>	<b>Info w</b> Initialized    Not initialized	Indicates the internally adjusted set point in the positioner (adjusted set point in 0 to 100 % according to the settings in <b>P6</b> and <b>P7</b> ). Touch * to display external set point (applied set point in 0 to 100 % according to the 4-20 mA signal).  Displays external set point in 0 to 100 % according to the 4-20 mA signal.

P15	<b>Start initialization</b>	Press * button to cancel the initialization process. As a result, the valve moves to the fail-safe position. After a power supply failure during initialization, the positioner starts with the values of the last initialization (if available).
P16	<b>Start zero calibration</b>	The zero calibration process can be interrupted by touching *. The control valve returns to closed-loop operation. <b>Note:</b> A zero calibration cannot be started when E1 error code exists. After a power supply failure during zero calibration, the positioner starts with the settings from the last zero calibration.
P17	<b>Manual mode</b>	Press ▲ or ▼ to enter the set point.
P18	<b>Reset</b>	Parameters are reset to their default setting. The positioner can only return to closed-loop operation after it has been re-initialized.
P19	<b>Enable configuration</b> [LOCK]/OPEN	Enable configuration to change parameter settings. This function is automatically canceled when none of the keys are touched within three minutes.
P20	<b>Firmware version</b>	Installed firmware version is displayed. Touch * to display the last four digits of the serial number.



(1) **EU-TYPE EXAMINATION CERTIFICATE**  
(Translation)

- (2) Equipment or Protective Systems Intended for Use in  
Potentially Explosive Atmospheres - **Directive 2014/34/EU**
- (3) EU-Type Examination Certificate Number:

**PTB 11 ATEX 2020 X**

**Issue: 1**

- (4) Product: e/p-positioner, type 3725-1100..
- (5) Manufacturer: SAMSON AG
- (6) Address: Weismüllerstraße 3, 60314 Frankfurt, Germany
- (7) This product and any acceptable variation thereto is specified in the schedule to this certificate and the documents therein referred to.
- (8) The Physikalisch-Technische Bundesanstalt, notified body No. 0102 in accordance with Article 17 of the Directive 2014/34/EU of the European Parliament and of the Council, dated 26 February 2014, certifies that this product has been found to comply with the Essential Health and Safety Requirements relating to the design and construction of products intended for use in potentially explosive atmospheres, given in Annex II to the Directive.
- The examination and test results are recorded in the confidential Test Report PTB Ex 19-29022.
- (9) Compliance with the Essential Health and Safety Requirements has been assured by compliance with:  
**EN 60079-0:2012 + A11:2013 EN 60079-11:2012**
- (10) If the sign "X" is placed after the certificate number, it indicates that the equipment is subject to the Specific Conditions of Use specified in the schedule to this certificate.
- (11) This EU-Type Examination Certificate relates only to the design and construction of the specified product in accordance to the Directive 2014/34/EU. Further requirements of the Directive apply to the manufacturing process and supply of this product. These are not covered by this certificate.
- (12) The marking of the product shall include the following:

 **II 2 G Ex ia IIC T4 Gb**

Konformitätsbewertungsstelle - Sektor Explosionsschutz Braunschweig, February 25, 2019

On behalf of PTB:

  
Dr.-Ing. F. Lienesch  
Direktor und Professor



ZSE001e c

sheet 1/3

EU-Type Examination Certificates without signature and official stamp shall not be valid. The certificates may be circulated only without alteration. Extracts or alterations are subject to approval by the Physikalisch-Technische Bundesanstalt. In case of dispute, the German text shall prevail.

Physikalisch-Technische Bundesanstalt • Bundesallee 100 • 38116 Braunschweig • GERMANY

## SCHEDULE

(13)

(14) **EU-Type Examination Certificate Number PTB 11 ATEX 2020 X, Issue: 1**

(15) Description of Product

The e/p-positioner, type 3725-1100.. is a single-acting positioner intended for the installation onto pneumatic lift drives and slewing-motion actuators. It is used for the assignment of a valve position to an actuating signal. Non-flammable media serve as pneumatic auxiliary power.

The e/p-positioner, type 3725-1100.. is a passive two-terminal network which may be connected to all certified intrinsically safe circuits provided that the permissible maximum values for  $U_i$ ,  $I_i$  and  $P_i$  are not exceeded.

The equipment is installed inside the hazardous area.

The permissible ambient temperature range is  $-25\text{ °C} \dots 80\text{ °C}$ .

### Electrical data

Signal circuit.....type of protection Intrinsic Safety Ex ia IIC  
(terminals 11/12) only for connection to a certified intrinsically safe circuit

Maximum values:

$U_i = 28\text{ V}$

$I_i = 115\text{ mA}$

$P_i = 1\text{ W}$

$C_i = 8.3\text{ nF}$

$L_i$  negligibly low

(16) Test Report PTB Ex 19-29022

(17) Specific conditions of use

The manufacturer documentation and the operating instructions manual shall include all required information to restrict the risk of electrostatic charge to a minimum. A warning label shall be affixed to the equipment.

sheet 2/3

EU-Type Examination Certificates without signature and official stamp shall not be valid. The certificates may be circulated only without alteration. Extracts or alterations are subject to approval by the Physikalisch-Technische Bundesanstalt. In case of dispute, the German text shall prevail.

Physikalisch-Technische Bundesanstalt • Bundesallee 100 • 38116 Braunschweig • GERMANY



**SCHEDULE TO EU-TYPE EXAMINATION CERTIFICATE PTB 11 ATEX 2020 X, Issue: 1**

(18) Essential health and safety requirements

Met by compliance with the aforementioned standards.

According to Article 41 of Directive 2014/34/EU, EC-type examination certificates which have been issued according to Directive 94/9/EC prior to the date of coming into force of Directive 2014/34/EU (April 20, 2016) may be considered as if they were issued already in compliance with Directive 2014/34/EU. By permission of the European Commission supplements to such EC-type examination certificates and new issues of such certificates may continue to hold the original certificate number issued before April 20, 2016.

Konformitätsbewertungsstelle, Sektor Explosionsschutz

Braunschweig, February 25, 2019

On behalf of PTB:

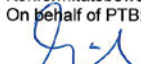
  
Dr.-Ing. F. Lienesch  
Direktor und Professor



sheet 3/3

EU-Type Examination Certificates without signature and official stamp shall not be valid. The certificates may be circulated only without alteration. Extracts or alterations are subject to approval by the Physikalisch-Technische Bundesanstalt. In case of dispute, the German text shall prevail.

Physikalisch-Technische Bundesanstalt • Bundesallee 100 • 38116 Braunschweig • GERMANY

## Installation Manual for Apparatus certified by CSA for use in Hazardous Locations

Electrical rating of Intrinsically Safe Apparatus for installation in Hazardous Locations

Table 1: Maximum values

Signal Circuit / Circuit No. 1		
Connection to terminals +11 / -12		
Type of protection:		Intrinsically Safe, AEx ia, Nonincendive
Rated current:		4 mA to 20 mA
Maximum values	$V_{max} / U_i$	28 V
	$I_{max} / I_i$	115 mA
	$P_i$	1 W
	$C_i$	8.3 nF
	$L_i$	negligible
Software Limit Switches / Circuit No. 2 and 3		
Connection to terminals +41 / -42 and +51 / -52		
Type of protection:		Intrinsically Safe, AEx ia, Nonincendive
Rated values:		For connection to NAMUR switching amplifier acc. to IEC 60947-5-6
Maximum values	$V_{max} / U_i$	20 V
	$I_{max} / I_i$	60 mA
	$P_i$	250 mW
	$C_i$	negligible
	$L_i$	negligible

Note: Entity / Nonincendive Wiring Parameters must meet the following requirements:

$$U_0 \text{ or } V_{OC} \leq U_i \text{ or } V_{max} / I_0 \text{ or } I_{SC} \leq I_i \text{ or } I_{max} / P_0 \leq P_i \text{ or } P_{max}$$

$$C_a \text{ or } C_0 \geq C_i + C_{Cable} / L_a \text{ or } L_0 \geq L_i + L_{Cable}$$

The correlation between Temperature Class and permissible ambient temperature range is shown in Table 2.

Table 2:

Temperature Class	Permissible ambient temperature $T_a$
T4	$-25 \text{ }^\circ\text{C} \leq T_a \leq +80 \text{ }^\circ\text{C}$

Intrinsically Safe when installed as specified in manufacturer's Installation Manual.

CSA – certified for Hazardous Locations

Ex ia IIC T4, Class I, Zone 0

AEx ia IIC T4, Class I, Zone 0

Class I, Division 1, Groups A, B, C, D

IP66

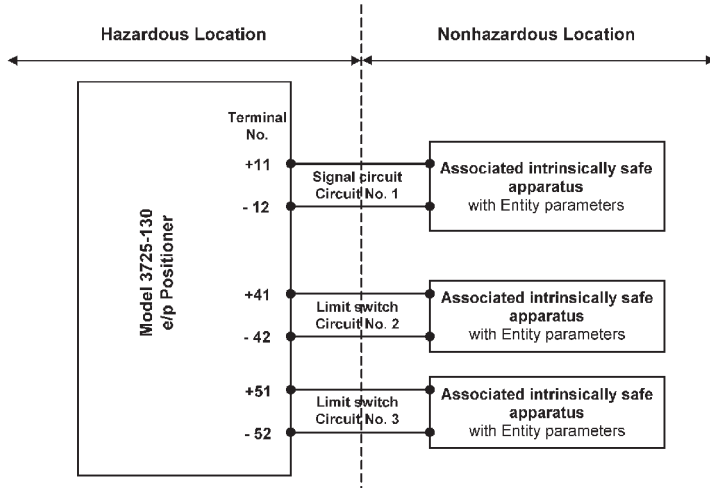

**Notes:**

1. The apparatus may be installed in intrinsically safe circuits only when used in conjunction with certified intrinsically safe associated apparatus. For maximum values see Table 1 on page 1.
2. For the interconnection of intrinsically safe and associated intrinsically safe apparatus not specifically examined in combination as a system, the Entity Parameters must meet following requirements:

$$\begin{aligned}
 V_{OC} \text{ or } U_0 &\leq U_i \text{ or } V_{max} \\
 I_{SC} \text{ or } I_0 &\leq I_i \text{ or } I_{max} \\
 P_0 &\leq P_i \text{ or } P_{max} \\
 C_B \text{ or } C_0 &\leq C_i + C_{Cable} \\
 L_a \text{ or } L_0 &\leq L_i + L_{Cable}
 \end{aligned}$$

3. The installation must be in accordance with Canadian Electrical Code C.E.C. Part 1.
4. The installation must be in accordance with the National Electrical Code NFPA 70 and ANSI/ISA RP 12.06.01.
5. Due to the high surface resistance avoid electrostatic charging of the enclosure when mounting and servicing the apparatus in hazardous areas.
6. Use only supply wires suitable for 5 °C above surrounding temperature.

CSA – certified for Hazardous Locations  
 Class I, Division 2, Groups A, B, C, D  
 IP66

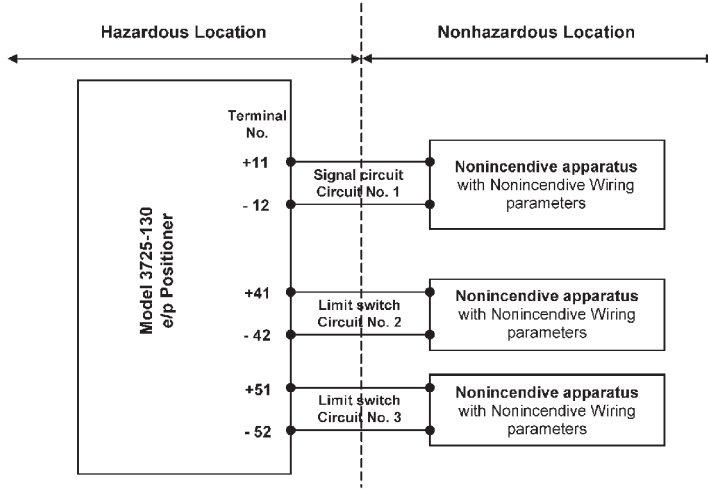

**Notes:**

1. The apparatus may be installed in nonincendive wiring circuits only when used in conjunction with certified nonincendive associated apparatus. For maximum values see Table 1 on Page 1.
2. For the interconnection of nonincendive and associated nonincendive apparatus not specifically examined in combination as a system, the Nonincendive Wiring parameters must meet following requirements:

$$\begin{aligned}
 V_{OC} \text{ or } U_0 &\leq U_i \text{ or } V_{max} \\
 I_{SC} \text{ or } I_0 &\leq I_i \text{ or } I_{max} \\
 P_0 &\leq P_i \text{ or } P_{max} \\
 C_R \text{ or } C_0 &\geq C_i + C_{Cable} \\
 L_0 \text{ or } L_0 &\geq L_i + L_{Cable}
 \end{aligned}$$

3. The installation must be in accordance with Canadian Electrical Code C.E.C. Part 1.
4. The installation must be in accordance with the National Electrical Code NFPA 70 and ANSI/ISA RP 12.06.01.
5. Due to the non-metallic enclosure make sure to install and service the device:
  - in such a way that electrostatic charging cannot take place,
  - in such a way that the enclosure is protected from mechanical impact.
6. Use only supply wires suitable for 5 °C above surrounding temperature.
7. Any hazard that could be caused in the valve by the process medium, the signal pressure or by moving parts are to be prevented by means of the appropriate measures.







**EB 8394 EN**



SAMSON AKTIENGESELLSCHAFT  
Weismüllerstraße 3 · 60314 Frankfurt am Main, Germany  
Phone: +49 69 4009-0 · Fax: +49 69 4009-1507  
samson@samsongroup.com · www.samsongroup.com