

MOUNTING AND OPERATING INSTRUCTIONS



EB 8135/8136 EN

Translation of original instructions



Type 3535 Three-way Valve with bellows seal and rod-type yoke (partial view)

Series V2001 Valves

Type 3535 Three-way Valve for Heat Transfer Oil

Edition April 2022



Note on these mounting and operating instructions

These mounting and operating instructions assist you in mounting and operating the device safely. The instructions are binding for handling SAMSON devices. The images shown in these instructions are for illustration purposes only. The actual product may vary.

- For the safe and proper use of these instructions, read them carefully and keep them for later reference.
- If you have any questions about these instructions, contact SAMSON's After-sales Service (aftersaleservice@samsongroup.com).



Documents relating to the device, such as the mounting and operating instructions, are available on our website at www.samsongroup.com > **Service & Support > Downloads > Documentation.**

Definition of signal words

DANGER

Hazardous situations which, if not avoided, will result in death or serious injury

WARNING

Hazardous situations which, if not avoided, could result in death or serious injury

NOTICE

Property damage message or malfunction

Note

Additional information

Tip

Recommended action

1	Safety instructions and measures	1-1
1.1	Notes on possible severe personal injury	1-4
1.2	Notes on possible personal injury	1-5
1.3	Notes on possible property damage	1-7
1.4	Warnings on the device.....	1-8
2	Markings on the device	2-1
2.1	Valve nameplate	2-1
2.2	Actuator nameplate.....	2-2
3	Design and principle of operation	3-1
3.1	Versions	3-1
3.2	Additional fittings.....	3-1
3.3	Technical data	3-4
4	Shipment and on-site transport	4-1
4.1	Accepting the delivered goods	4-1
4.2	Removing the packaging from the valve.....	4-1
4.3	Transporting and lifting the valve.....	4-1
4.3.1	Transporting the valve	4-2
4.3.2	Lifting the valve.....	4-3
4.4	Storing the valve	4-3
5	Installation	5-1
5.1	Installation conditions	5-1
5.2	Preparation for installation.....	5-2
5.3	Mounting the device.....	5-2
5.3.1	Mounting the actuator onto the valve.....	5-4
5.3.2	Installing the valve into the pipeline	5-4
5.4	Testing the installed valve.....	5-5
5.4.1	Leak test	5-6
5.4.2	Travel motion	5-6
5.4.3	Fail-safe position.....	5-6
5.4.4	Pressure test.....	5-6
6	Start-up	6-1
7	Operation	7-1
8	Malfunctions	8-1
8.1	Troubleshooting	8-1
8.2	Emergency action	8-3

Contents

9	Servicing.....	9-1
9.1	Periodic testing	9-3
9.2	Preparing the valve for service work	9-3
9.3	Installing the valve after service work	9-3
9.4	Service work.....	9-5
9.4.1	Replacing the metal bellows	9-5
9.4.2	Replacing the seat and plug.....	9-7
9.5	Ordering spare parts and operating supplies	9-16
10	Decommissioning	10-1
11	Removal	11-1
11.1	Removing the valve from the pipeline.....	11-1
11.2	Removing the actuator from the valve	11-2
12	Repairs	12-1
12.1	Returning devices to SAMSON	12-1
13	Disposal.....	13-1
14	Certificates.....	14-1
15	Annex.....	15-1
15.1	Tools and tightening torques.....	15-1
15.2	Spare parts	15-1
15.3	After-sales service	15-3

1 Safety instructions and measures

Intended use

The Type 3535 Three-way Valve in combination with actuator is designed as a mixing or diverting valves (depending on how the plug arrangement) for heat transfer applications using organic media according to DIN 4745.

The valve with its actuator is designed to operate under exactly defined conditions (e.g. operating pressure, process medium, temperature). Therefore, operators must ensure that the control valve is only used in operating conditions that meet the specifications used for sizing the valve at the ordering stage. In case operators intend to use the control valve in other applications or conditions than specified, contact SAMSON.

SAMSON does not assume any liability for damage resulting from the failure to use the device for its intended purpose or for damage caused by external forces or any other external factors.

→ Refer to the technical data and nameplate for limits and fields of application as well as possible uses.

Reasonably foreseeable misuse

The control valve is not suitable for the following applications:

- Use outside the limits defined during sizing and by the technical data
- Use outside the limits defined by the valve accessories connected to the valve

Furthermore, the following activities do not comply with the intended use:

- Use of non-original spare parts
- Performing service and repair work not described

Qualifications of operating personnel

The control valve must be mounted, started up, serviced and repaired by fully trained and qualified personnel only; the accepted industry codes and practices must be observed. According to these mounting and operating instructions, trained personnel refers to individuals who are able to judge the work they are assigned to and recognize possible hazards due to their specialized training, their knowledge and experience as well as their knowledge of the applicable standards.

Explosion-protected versions of this device must be operated only by personnel who has undergone special training or instructions or who is authorized to work on explosion-protected devices in hazardous areas.

Safety instructions and measures

Personal protective equipment

We recommend checking the hazards posed by the process medium being used (e.g.

▶ GESTIS (CLP) hazardous substances database). Depending on the process medium and/or the activity, the protective equipment required includes:

- Protective clothing, gloves, eye protection and respiratory protection in applications with hot, cold and/or corrosive media
 - Wear hearing protection when working near the valve
 - Hard hat
 - Safety harness when working at height
 - Safety footwear, ESD (electrostatic discharge) footwear, if necessary
- ➔ Check with the plant operator for details on further protective equipment.

Revisions and other modifications

Revisions, conversions or other modifications of the product are not authorized by SAMSON. They are performed at the user's own risk and may lead to safety hazards, for example. Furthermore, the product may no longer meet the requirements for its intended use.

Safety features

The fail-safe position of the control valve upon air supply or control signal failure depends on the actuator used (see associated actuator documentation). The fail-safe action of the actuator is the same as its direction of action and is specified on the nameplate of SAMSON actuators.

Warning against residual hazards

To avoid personal injury or property damage, plant operators and operating personnel must prevent hazards that could be caused in the control valve by the process medium, the operating pressure, the signal pressure or by moving parts by taking appropriate precautions. Plant operators and operating personnel must observe all hazard statements, warning and caution notes in these mounting and operating instructions.

Hazards resulting from the special working conditions at the installation site of the valve must be identified in a risk assessment and prevented through the corresponding safety instructions drawn up by the operator.

Responsibilities of the operator

Operators are responsible for proper use and compliance with the safety regulations. Operators are obliged to provide these mounting and operating instructions as well as the referenced documents to the operating personnel and to instruct them in proper operation. Furthermore, operators must ensure that operating personnel or third parties are not exposed to any danger.

Operators are additionally responsible for ensuring that the limits for the product defined in the technical data are observed. This also applies to the start-up and shutdown procedures. Start-up and shutdown procedures fall within the scope of the operator's duties and, as such, are not part of these mounting and operating instructions. SAMSON is unable to make any statements about these procedures since the operative details (e.g. differential pressures and temperatures) vary in each individual case and are only known to the operator.

Responsibilities of operating personnel

Operating personnel must read and understand these mounting and operating instructions as well as the referenced documents and observe the specified hazard statements, warnings and caution notes. Furthermore, operating personnel must be familiar with the applicable health, safety and accident prevention regulations and comply with them.

Referenced standards, directives and regulations

The control valves comply with the requirements of the European Pressure Equipment Directive 2014/68/EU. Valves with a CE marking have a declaration of conformity, which includes information about the applied conformity assessment procedure. The 'Certificates' section contains this declaration of conformity.

According to the ignition hazard assessment performed in accordance with Clause 5.2 of ISO 80079-36, the non-electrical control valves do not have their own potential ignition source even in the rare incident of an operating fault. As a result, they do not fall within the scope of Directive 2014/34/EU.

→ For connection to the equipotential bonding system, observe the requirements specified in section 6.4 of EN 60079-14 (VDE 0165-1).

Referenced documentation

The following documents apply in addition to these mounting and operating instructions:

- Mounting and operating instructions for the mounted actuator, for example:
 - ▶ EB 8317 for SAMSON Type 3371 Pneumatic Actuator
 - ▶ EB 8313 for SAMSON Type 3372 Pneumatic or Electropneumatic Actuator
 - ▶ EB 8331-X for SAMSON Type 3374 Electric Actuator
 - ▶ EB 5824-X for SAMSON Type 5824 Electric Actuator
 - ▶ EB 5827-X for SAMSON Type 5827 Electric Actuator
- Mounting and operating instructions for mounted valve accessories (positioner, solenoid valve etc.)

1.1 Notes on possible severe personal injury

DANGER

Risk of bursting in pressure equipment.

Valves and pipelines are pressure equipment. Impermissible pressure or improper opening can lead to valve components bursting.

- Observe the maximum permissible pressure for valve and plant.
- Before starting any work on the control valve, depressurize all plant sections affected as well as the valve.
- Drain the process medium from all the plant sections concerned as well as the valve.

Risk of fatal injury due to electric shock.

- Do not remove any covers to perform adjustment work on live parts.
- Before performing any work on the device and before opening the device, disconnect the supply voltage and protect it against unintentional reconnection.
- Only use power interruption devices that are protected against unintentional reconnection of the power supply.

1.2 Notes on possible personal injury

WARNING

Risk of burn injuries due to hot or cold components and pipelines.

Depending on the process medium, valve components and pipelines may get very hot or cold and cause burn injuries.

- Allow components and pipelines to cool down or warm up to the ambient temperature.
- Wear protective clothing and safety gloves.

Risk of hearing loss or deafness due to loud noise.

The noise emissions depend on the valve version, plant facilities and process medium.

- Wear hearing protection when working near the valve.

Risk of personal injury due to exhaust air being vented from pneumatically operated components.

While the valve is operating, the pneumatic actuator may vent during closed-loop control or when the valve opens or closes.

- Install the control valve in such a way that vent openings are not located at eye level and the actuator does not vent at eye level in the work position.
- Use suitable silencers and vent plugs.
- Wear eye protection when working in close proximity to the control valve.

Risk of personal injury due to preloaded springs in pneumatic actuators.

Valves in combination with pneumatic actuators with preloaded springs are under tension. These control valves with SAMSON pneumatic actuators can be identified by the long bolts protruding from the bottom of the actuator.

- Before starting any work on the actuator, relieve the compression from the preloaded springs (see associated actuator documentation).

WARNING

Crush hazard arising from moving parts.

The control valve contains moving parts (actuator and plug stem), which can injure hands or fingers if inserted into the valve.

- Do not insert hands or finger into the yoke while the air supply is connected to the actuator.
- Before working on the control valve, disconnect and lock the pneumatic air supply as well as the control signal.
- Do not impede the movement of the actuator and plug stem by inserting objects into the yoke.
- Before unblocking the actuator and plug stem after they have become blocked (e.g. due to seizing up after remaining in the same position for a long time), release any stored energy in the actuator (e.g. spring compression). See associated actuator documentation.

Risk of personal injury due to residual process medium in the valve.

While working on the valve, residual medium can flow out of the valve and, depending on its properties, cause personal injury, e.g. (chemical) burns.

- If possible, drain the process medium from all the plant sections affected and the valve.
- Wear protective clothing, safety gloves, respiratory protection and eye protection.

Risk of personal injury through incorrect operation, use or installation as a result of information on the valve being illegible.

Over time, markings, labels and nameplates on the valve may become covered with dirt or become illegible in some other way. As a result, hazards may go unnoticed and the necessary instructions not followed. There is a risk of personal injury.

- Keep all relevant markings and inscriptions on the device in a constantly legible state.
- Immediately renew damaged, missing or incorrect nameplates or labels.

1.3 Notes on possible property damage

! NOTICE

Risk of damage to the electric control valve due to the supply voltage exceeding the permissible tolerances.

The electric control valves are designed for use according to regulations for low-voltage installations.

- Observe the permissible tolerances of the supply voltage. See associated actuator documentation.

Risk of valve damage due to contamination (e.g. solid particles) in the pipeline.

The plant operator is responsible for cleaning the pipelines in the plant.

- Flush the pipelines before start-up.

Risk of valve damage due to unsuitable medium properties.

The valve is designed for a process medium with defined properties.

- Only use the process medium specified for sizing the valve.

Risk of leakage and valve damage due to excessively high or low tightening torques.

Observe the specified torques when tightening control valve components. Excessive tightening torques lead to parts wearing out more quickly. Parts that are too loose may cause leakage.

- Observe the specified tightening torques.

Risk of valve damage due to the use of unsuitable tools.

Certain tools are required to work on the valve.

- Only use tools approved by SAMSON.

Risk of valve damage due to the use of unsuitable lubricants.

The lubricants to be used depend on the valve material. Unsuitable lubricants may corrode and damage surfaces.

- Only use lubricants approved by SAMSON.

Risk of the process medium being contaminated through the use of unsuitable lubricants and/or contaminated tools and components.

- If necessary, keep the valve and the tools used free from solvents and grease.
- Make sure that only suitable lubricants are used.

1.4 Warnings on the device

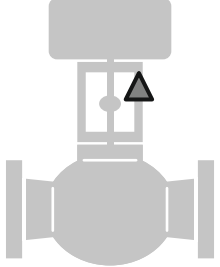
Warning	Meaning of the warning	Location on the device
	<p>Warning against moving parts There is a risk of injury to hands or fingers through the stroking movement of the actuator and plug stem if they are inserted into the yoke while the air supply is connected to the actuator.</p>	

2 Markings on the device

2.1 Valve nameplate

The DIN or ANSI versions have different specifications on the nameplates.

DIN version

1	Valve type	9	Pressure rating
2	Model number	11	Permissible temperature (°C)
3	Model number index	12	Body material
4	Order number or date		
5	K _{VS} coefficient		
8	Valve size		

ANSI version

1	Valve type	10	Body material
2	Model number	11	C _v coefficient
3	Model number index	12	Pressure rating (Class)
4	Order number or date		
5	Valve size		
9	Permissible temperature [°F]		

2.2 Actuator nameplate

See associated actuator documentation.

3 Design and principle of operation

Depending on the plug arrangement, the three-way valve can be used either as a mixing or diverting valve.

In mixing valves, the process media to be mixed enter at valve ports A and B. The combined flow exits the valve at port AB.

In diverting valves, the process medium enters at the valve port AB and the partial flows exit at ports A and B.

The flow rate from ports A or B to AB and vice versa depends on the cross-sectional area of flow between the seats and plugs.

The plug (3, 3.1, 3.2) is moved by changing the control signal applied to the actuator.

The plug stem is sealed by a bellows seal and an additional packing (4.2) and is connected to the actuator stem (8.1) by the stem connector (7).

3.1 Versions

Actuators

The Type 3535 Three-way Valve has a modular design and can be combined with pneumatic or electric actuators (as follows):

Valve		Type ... Actuator
3535-P	Pneumatic	3371-01xx
3535-IP	Electropneumatic	3372-03xx
3535-E1	Electric	5824-30 ¹⁾
		5827-N3
3535-E3		3374

¹⁾ The product will be discontinued in the near future. See Data Sheet ▶ T 5827 for replacement device.

3.2 Additional fittings

Strainers

SAMSON We recommend installing a **SAMSON** strainer upstream of the valve (upstream of both inlet ports in mixing valves). It prevents solid particles in the process medium from damaging the valve.

Bypass and shut-off valves

We recommend installing a shut-off valve both upstream of the strainer and downstream of the valve and installing a bypass line. The bypass ensures that the plant does not need to be shut down for service and repair work on the valve.

Safety guard

For operating conditions that require increased safety (e.g. in cases where the valve is freely accessible to untrained staff), a safety guard must be installed to rule out a crush hazard arising from moving parts (actuator and plug stem). Plant operators are responsible for deciding whether a guard is to be used. The decision is based on the risk posed by the plant and its operating conditions.

Design and principle of operation

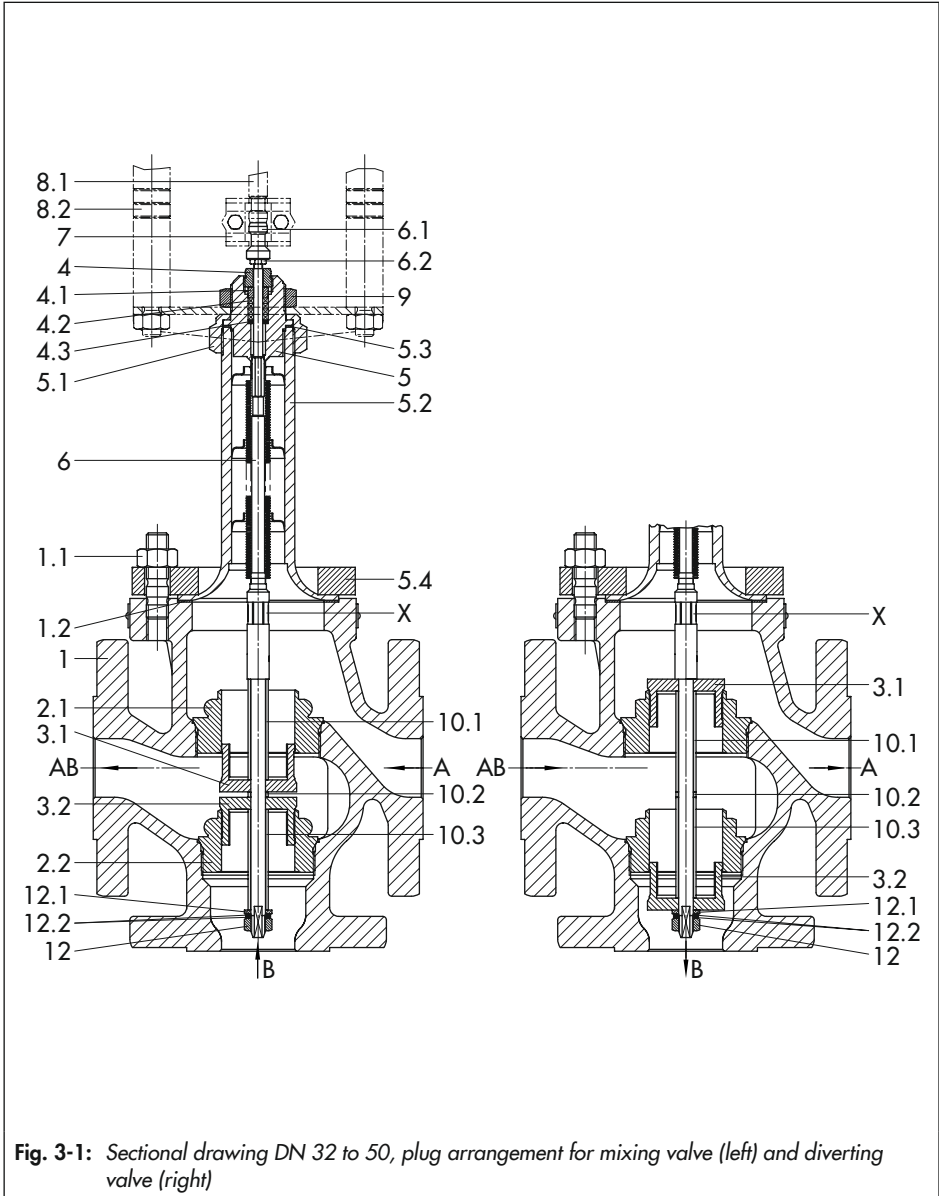

Fig. 3-1: Sectional drawing DN 32 to 50, plug arrangement for mixing valve (left) and diverting valve (right)

1	Valve body	4.3	Washer	8.1	Actuator stem
1.1	Nuts	5	Bellows seal with plug stem	8.2	Rod-type yoke
1.2	Gasket			9	Nut
2.1	Top seat	5.1	Coupling nut	10.1	Sleeve
2.2	Bottom seat	5.2	Bellows housing	10.2	Short sleeve
3.1	Top plug	5.3	Gasket	10.3	Sleeve
3.2	Bottom plug	5.4	Flange	12	Nut
4	Threaded bushing	6	Plug stem	12.1	Washer
4.1	Bushing	6.1	Stem connector nut	12.2	Retaining washers
4.2	Packing (spring-loaded for DN 65 and larger)	6.2	Lock nut	X	Position for open-end wrench
		7	Stem connector		

3.3 Technical data

The nameplates on the valve and actuator provide information on the control valve version. See the 'Markings on the device' section.

Noise emissions

SAMSON is unable to make general statements about noise emissions. The noise emissions depend on the valve version, plant facilities and process medium.

Table 3-1: Technical data for Type 3535

Valve size	DN 15 to 80			NPS ½ to 3	
Material	Spheroidal graphite iron EN-JS1049	Cast steel 1.0619	Stainless steel 1.4408	Cast steel A216 WCC	Stainless steel A351 CF8M
Pressure rating	PN 16 · PN 25			Class 150 · Class 300	
Connection Flanges	EN 1092-1 form B1, Ra 3.2 to 12.5 µm EN 1092-1, groove form D			Raised face	
Seat-plug seal	Metal seal				
Characteristic	Linear				
Rangeability	30:1 up to DN 25/NPS 1 · 50:1 for DN 32/NPS 1 and larger				
Temperature range	-10 to +350 °C			14 to 660 °F	
Leakage class	DIN EN 1349: 0.05 % of K_{VS}			ANSI/FCI 70-2: 0.05 % of C_V	
Conformity	CE · EAC				

Table 3-2: Materials

Valve size	DN 15 to 80			NPS ½ to 3	
Valve body	Spheroidal graphite iron EN-JS1049	Cast steel 1.0619	Stainless steel 1.4408	Cast steel A216 WCC	Stainless steel A351 CF8M
Valve bonnet	Cast steel S235JR (St 37)		1.4408	Cast steel S235JR (St 37)	1.4408
Seat	≤DN 25: 1.4305 · ≥DN 32: 1.4104			≤NPS 1: 1.4305 · ≥NPS 1½: 1.4104	
Plug	1.4305				
Bellows seal	1.4541 · 1.4301				
Packing	PTFE				
Body gasket	Graphite on metal core				

Table 3-3: K_{VS} and C_V coefficients, seat diameters and travel

Valve size	DN	15	20	25	32	40	50	65	80
	NPS	½	¾	1	–	1½	2	2½	3
K_{VS} coefficients		4	6.3	8	16	20	32	50	80
C_V coefficients		5	7.5	9.4	–	23	37	60	94
Seat Ø	mm/in	24/0.94			40/1.57			65/2.56	
Travel	mm/in	15/0.59			15/0.59			15/0.59	

Table 3-4: Dimensions in mm and inches

DIN version					
DN	L (mm)		H (mm)	H2 (mm)	
15	130		235	70	
20	150			80	
25	160			85	
32	180		245	100	
40	200			105	
50	230			120	
65	290		350	130	
80	310			140	
ANSI version					
NPS	L (in)		H (in)	H2 (in)	
	Class 150	Class 300		Class 150	Class 300
½	7.25	7.50	9.25	3.62	3.76
¾		7.62			3.82
2		7.75			3.88
1½	8.75	9.25	9.65	4.37	4.63
2	10.00	10.50		5.00	5.26
2½	10.78	11.50	13.78	5.43	5.75
3	11.75	12.50		5.87	6.26

Dimensional drawing

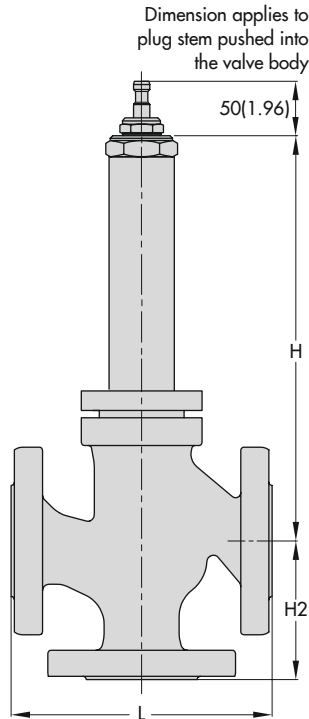

Fig. 3-2: Dimensional drawing of Type 3535

i Note

Refer to the following data sheets for more information:

▶ T 8135 and ▶ T 8136

The associated actuator documentation applies to actuators, e.g. SAMSON actuators:

▶ T 8317 for SAMSON Type 3371 Pneumatic Actuator

▶ T 8313 for SAMSON Type 3372 Pneumatic or Electropneumatic Actuator

▶ T 8331 for SAMSON Type 3374 Electric Actuator

▶ T 5824 for SAMSON Type 5824 Electric Actuator

▶ T 5827 for SAMSON Type 5827 Electric Actuator

4 Shipment and on-site transport

The work described in this section is only to be performed by personnel appropriately qualified to carry out such tasks.

4.1 Accepting the delivered goods

After receiving the shipment, proceed as follows:

1. Check the scope of delivery. Check that the specifications on the valve nameplate match the specifications in the delivery note. See the 'Markings on the device' section for nameplate details.
2. Check the shipment for transportation damage. Report any damage to SAMSON and the forwarding agent (refer to delivery note).
3. Determine the weight and dimensions of the units to be lifted and transported in order to select the appropriate lifting equipment and lifting accessories, if required. Refer to the transport documents and the 'Technical data' section.

4.2 Removing the packaging from the valve

Observe the following sequence:

- Do not open or remove the packaging until immediately before lifting to install the valve into the pipeline.

- Leave the control valve in its transport container or on the pallet to transport it on site.
- Do not remove the protective caps from the inlet and outlet until immediately before installing the valve into the pipeline. They prevent foreign particles from entering the valve.
- Dispose and recycle the packaging in accordance with the local regulations.

4.3 Transporting and lifting the valve

⚠ DANGER

Danger due to suspended loads falling.

- *Stay clear of suspended or moving loads.*
 - *Close off and secure the transport paths.*
-

⚠ WARNING

Risk of lifting equipment tipping over and risk of damage to lifting accessories due to exceeding the rated lifting capacity.

- *Only use approved lifting equipment and accessories whose minimum lifting capacity is higher than the weight of the valve (including actuator and packaging, if applicable).*
-

WARNING

Risk of personal injury due to the control valve tipping over.

- Observe the valve's center of gravity.
- Secure the valve against tipping over or turning.

WARNING

Risk of injury due to incorrect lifting without the use of lifting equipment.

Lifting the control valve without the use of lifting equipment may lead to injuries (back injury in particular) depending on the weight of the control valve.

- Observe the occupational health and safety regulations valid in the country of use.

NOTICE

Risk of valve damage due to incorrectly attached slings.

- When lifting the control valve, make sure that the slings attached to the valve body bear the entire load.
- Do not attach load-bearing slings to the actuator or any mounting parts.
- Only use slings which are not attached to the valve body to protect the control valve from tilting while being lifted.
- Observe lifting instructions (see section 4.3.2).

Tip

Our after-sales service can provide more detailed transport and lifting instructions on request.

4.3.1 Transporting the valve

The control valve can be transported using lifting equipment (e.g. crane or forklift).

- Leave the control valve in its transport container or on the pallet to transport it.
- Observe the transport instructions.

Transport instructions

- Protect the control valve against external influences (e.g. impact).
- Do not damage the corrosion protection (paint, surface coatings). Repair any damage immediately.
- Protect the piping and any mounted valve accessories against damage.
- Protect the control valve against moisture and dirt.
- The permissible transportation temperature of standard control valves is -20 to $+65$ °C.

Note

Contact our after-sales service for the transportation temperatures of other valve versions.

4.3.2 Lifting the valve

To install a large valve into the pipeline, use lifting equipment (e.g. crane or forklift) to lift it.

Lifting instructions

- Use a hook with safety latch to secure the slings from slipping off the hook during lifting and transporting.
- Secure slings against slipping.
- Make sure the slings can be removed from the valve once it has been installed into the pipeline.
- Prevent the control valve from tilting or tipping over.
- Do not leave loads suspended when interrupting work for longer periods of time.

Lifting the control valve

1. Attach one sling to each flange of the body and to the rigging equipment (e.g. hook) of the crane or forklift.
2. If necessary, attach further slings to the control valve and rigging equipment to secure the position of the control valve while it is being lifted.
3. Carefully lift the control valve. Check whether the lifting equipment and accessories can bear the weight.
4. Move the control valve at an even pace to the site of installation.
5. Install the valve into the pipeline (see the 'Installation' section).

6. After installation in the pipeline, check whether the flanges are bolted tight and the valve in the pipeline holds.
7. Remove slings.

4.4 Storing the valve

! NOTICE

Risk of valve damage due to improper storage.

- *Observe the storage instructions.*
 - *Avoid long storage times.*
 - *Contact SAMSON in case of different storage conditions or longer storage times.*
-

i Note

We recommend regularly checking the control valve and the prevailing storage conditions during long storage periods.

Storage instructions

- Protect the control valve against external influences (e.g. impact).
- Do not damage the corrosion protection (paint, surface coatings). Repair any damage immediately.
- Protect the control valve against moisture and dirt. Store it at a relative humidity of less than 75 %. In damp spaces, prevent condensation. If necessary, use a drying agent or heating.
- Make sure that the ambient air is free of acids or other corrosive media.

Shipment and on-site transport

- The permissible storage temperature of standard control valves is -20 to $+65$ °C. Contact our after-sales service for the storage temperatures of other valve versions.
- Do not place any objects on the control valve.

Special storage instructions for elastomers

Elastomer, e.g. actuator diaphragm

- To keep elastomers in shape and to prevent cracking, do not bend them or hang them up.
- We recommend a storage temperature of 15 °C for elastomers.
- Store elastomers away from lubricants, chemicals, solutions and fuels.



Tip

SAMSON's After-sales Service can provide more detailed storage instructions on request.

5 Installation

The work described in this section is only to be performed by personnel appropriately qualified to carry out such tasks.

5.1 Installation conditions

Work position

The work position for the control valve is the front view looking onto the operating controls (including valve accessories).

Plant operators must ensure that, after installation of the device, the operating personnel can perform all necessary work safely and easily access the device from the work position.

Pipeline routing

To ensure that the control valve functions properly, the pipeline must be straight and without any manifolds or disturbances for a distance of at least 6 times the valve size (DN) upstream and downstream of the valve.

Make sure the following conditions are met:

- Contact SAMSON if the undisturbed installation lengths are significantly shorter than recommended by SAMSON or if the valve conditions or states of the medium process are different than specified.
- Install the valve free of stress and with the least amount of vibrations as possible. Read information under 'Mounting position' and 'Work position' in this section.
- Install the valve allowing sufficient space to remove the actuator and valve or to

perform service and repair work on them.

Mounting position

The valve can be mounted in any desired position.

- ➔ Observe the restrictions for the actuator used.

Support or suspension

i Note

The plant engineering company is responsible for selecting and implementing a suitable support or suspension of the pipeline

Depending on the valve version and mounting position, the pipeline must be supported or suspended close to the joints.

Do not attach supports directly to the valve or actuator.

Valve accessories

During connection of valve accessories, make sure that they are easily accessible and can be operated safely from the work position.

Vent plugs

Vent plugs are screwed into the exhaust air ports of pneumatic and electropneumatic devices. They ensure that any exhaust air that forms can be vented to the atmosphere (to avoid excess pressure in the device). Furthermore, the vent plugs allow air intake to prevent a vacuum from forming in the device.

Installation

- Locate the vent plug on the opposite side to the work position of operating personnel.

5.2 Preparation for installation

Before installation, make sure the following conditions are met:

- The valve is clean.
- The valve and all valve accessories (including piping) are not damaged.
- The valve data on the nameplate (type designation, valve size, material, pressure rating and temperature range) match the plant conditions (size and pressure rating of the pipeline, medium temperature etc.). See the 'Markings on the device' section for nameplate details.
- The requested or required additional pipe fittings (see 'Additional fittings' in the 'Design and principle of operation' section) have been installed or prepared as necessary before installing the valve.

Proceed as follows:

- Lay out the necessary material and tools to have them ready during installation work.
- Flush the pipelines.

i Note

The plant operator is responsible for cleaning the pipelines in the plant.

- For steam applications, dry the pipelines. Moisture will damage the inside of the valve.

- Check any mounted pressure gauges to make sure they function properly.
- When the valve and actuator are already assembled, check the tightening torques of the bolted joints. Components may loosen during transport.

5.3 Mounting the device

The activities listed below are necessary to install the valve and before it can be started up.

! NOTICE

Risk of valve damage due to excessively high or low tightening torques.

Observe the specified torques when tightening control valve components. Excessive tightening torques lead to parts wearing out more quickly. Parts that are too loose may cause leakage.

- *Observe the specified tightening torques.*
-

! NOTICE

Risk of valve damage due to the use of unsuitable tools.

- *Only use tools approved by SAMSON.*
-

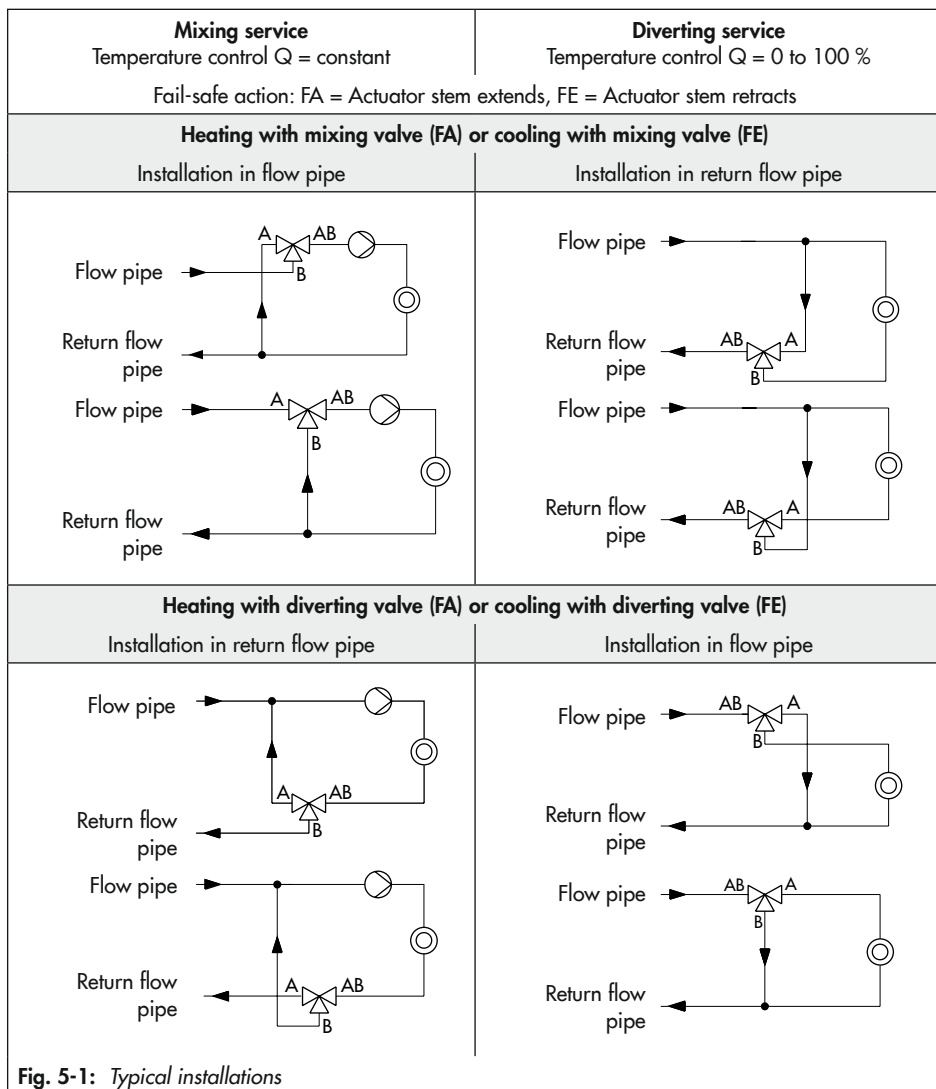

5.3.1 Mounting the actuator onto the valve

⚠ WARNING

Risk of personal injury due to preloaded springs in pneumatic actuators.

Actuators with preloaded springs are under tension. They can be identified by the long bolts protruding from the bottom of the actuator.

→ Before starting any work on the actuator, relieve the compression from the preloaded springs (see associated actuator documentation).

⚠ DANGER

Risk of fatal injury due to electric shock.

→ Do not remove any covers to perform adjustment work on live parts.

→ Before performing any work on the device and before opening the device, disconnect the supply voltage and protect it against unintentional reconnection.

→ Only use power interruption devices that are protected against unintentional reconnection of the power supply.

Depending on the version, SAMSON control valves are either delivered with the actuator already mounted on the valve or the valve and actuator are delivered separately. When delivered separately, the valve and actuator must be assembled together on site.

Mounting the actuator

→ To mount the actuator, proceed as described in the associated actuator documentation.

5.3.2 Installing the valve into the pipeline

ⓘ NOTICE

Premature wear and leakage due to insufficient support or suspension.

→ Support or suspend the valve sufficiently at suitable points.

1. Close the shut-off valves in the pipeline at the inlet and outlet of the plant section while the valve is being installed.
2. Prepare the relevant section of the pipeline for installing the valve.
3. Remove the protective caps from the valve ports before installing the valve.
4. Lift the valve using suitable lifting equipment to the site of installation (see information under 'Lifting the valve' in the 'Shipment and on-site transport' section).
5. Install the valve as shown in Fig. 5-1 depending on whether it is to be used for mixing or diverting service.

The plug arrangement (i.e. either mixing or diverting valve) is indicated on a label attached to the valve body.

Fail-safe action: the valve shuts off the flow of the heating medium or opens the flow of the cooling medium.

6. Make sure that the correct flange gaskets are used.
 7. Bolt the pipe to the valve free of stress.
 8. Attach a support or suspension on the valve, if necessary.
- Wear hearing protection when working near the valve.

5.4 Testing the installed valve

⚠ DANGER

Risk of bursting due to incorrect opening of pressurized equipment or components.

Valves and pipelines are pressure equipment that may burst when handled incorrectly. Flying projectile fragments or the release of process medium under pressure can cause serious injury or even death.

Before working on the control valve:

- Depressurize all plant sections affected and the valve (including the actuator). Release any stored energy.
- Drain the process medium from all the plant sections concerned as well as the valve.

⚠ WARNING

Risk of hearing loss or deafness due to loud noise.

Noise emission (e.g. cavitation or flashing) may occur during operation caused by the process medium and the operating conditions. Additionally, a loud noise may briefly occur through the sudden venting of the pneumatic actuator or pneumatic valve accessories not fitted with noise-reducing fittings. Both can damage hearing.

⚠ WARNING

Crush hazard arising from actuator and plug stem moving.

- Do not insert hands or finger into the yoke while the air supply is connected to the actuator.
- Before working on the control valve, disconnect and lock the pneumatic air supply as well as the control signal.
- Do not impede the movement of the actuator and plug stem by inserting objects into the yoke.
- Before unblocking the actuator and plug stem after they have become blocked (e.g. due to seizing up after remaining in the same position for a long time), release any stored energy in the actuator (e.g. spring compression). See associated actuator documentation.

⚠ WARNING

Risk of personal injury due to exhaust air being vented from pneumatic devices.

While the valve is operating, the pneumatic actuator may vent during closed-loop control or when the valve opens or closes.

- Wear eye protection when working in close proximity to the control valve.

Installation

To test the valve functioning before start-up or putting back the valve into operation, perform the following tests:

5.4.1 Leak test

The plant operator is responsible for performing the leak test and selecting the test method. The leak test must comply with the requirements of the national and international standards that apply at the site of installation.



Tip

Our after-sales service can support you to plan and perform a leak test for your plant.

1. Close the valve.
 2. Slowly apply the test medium to the inlet space upstream of the valve. A sudden surge in pressure and resulting high flow velocities can damage the valve.
 3. Open the valve.
 4. Apply the required test pressure.
 5. Check the valve for leakage to the atmosphere.
 6. Depressurize the pipeline section and valve.
 7. Rework any parts that leak and repeat the leak test.
- ➔ If the metal bellows and packing do not seal the plug stem properly, contact our after-sales service or replace the bellows and packing (see the 'Servicing' section).

5.4.2 Travel motion

The movement of the actuator stem must be linear and smooth.

- ➔ Apply the maximum and minimum control signals to check the end positions of the valve while observing the movement of the actuator stem.
- ➔ Check the travel reading at the travel indicator scale.

5.4.3 Fail-safe position

- ➔ Shut off the signal pressure line.
- ➔ Check whether the valve moves to the fail-safe position (see the associated actuator documentation).

5.4.4 Pressure test

The plant operator is responsible for performing the pressure test.



Tip

Our after-sales service can support you to plan and perform a pressure test for your plant.

During the pressure test, make sure the following conditions are met:

- Retract the plug stem to open the valve.
- Observe the maximum permissible pressure for both the valve and plant.

6 Start-up

The work described in this section is only to be performed by personnel appropriately qualified to carry out such tasks.

⚠ WARNING

Risk of burn injuries due to hot or cold components and pipeline.

Valve components and the pipeline may become very hot or cold. Risk of burn injuries.

- Allow components and pipelines to cool down or warm up to the ambient temperature.
- Wear protective clothing and safety gloves.

⚠ WARNING

Risk of hearing loss or deafness due to loud noise.

Noise emission (e.g. cavitation or flashing) may occur during operation caused by the process medium and the operating conditions. Additionally, a loud noise may briefly occur through the sudden venting of the pneumatic actuator or pneumatic valve accessories not fitted with noise-reducing fittings. Both can damage hearing.

- Wear hearing protection when working near the valve.

⚠ WARNING

Crush hazard arising from actuator and plug stem moving.

- Do not insert hands or finger into the yoke while the air supply is connected to the actuator.
- Before working on the control valve, disconnect and lock the pneumatic air supply as well as the control signal.
- Do not impede the movement of the actuator and plug stem by inserting objects into the yoke.
- Before unblocking the actuator and plug stem after they have become blocked (e.g. due to seizing up after remaining in the same position for a long time), release any stored energy in the actuator (e.g. spring compression). See associated actuator documentation.

⚠ WARNING

Risk of personal injury due to exhaust air being vented from pneumatic devices.

While the valve is operating, the pneumatic actuator may vent during closed-loop control or when the valve opens or closes.

- Wear eye protection when working in close proximity to the control valve.

Before start-up or putting the valve back into service, make sure the following conditions are met:

- The valve is properly installed into the pipeline (see the 'Installation' section).
- The leak and function tests have been completed successfully (see 'Testing the

Start-up

installed valve' in the 'Installation' section).

- The prevailing conditions in the plant section concerned meet the valve sizing requirements (see information under 'Intended use' in the 'Safety instructions and measures' section).

Start-up/putting the valve back into operation

1. Allow the valve to cool down or warm up to reach ambient temperature before start-up when the ambient temperature and process medium temperature differ greatly or the medium properties require such a measure.
2. Slowly open the shut-off valves in the pipeline. Slowly opening these valves prevents a sudden surge in pressure and high flow velocities which can damage the valve.
3. Check the valve to ensure it functions properly.

7 Operation

Immediately after completing start-up or putting the valve back into operation, the valve is ready for use.

⚠ WARNING

Risk of burn injuries due to hot or cold components and pipeline.

Valve components and the pipeline may become very hot or cold. Risk of burn injuries.

- Allow components and pipelines to cool down or warm up to the ambient temperature.
- Wear protective clothing and safety gloves.

⚠ WARNING

Risk of hearing loss or deafness due to loud noise.

Noise emission (e.g. cavitation or flashing) may occur during operation caused by the process medium and the operating conditions. Additionally, a loud noise may briefly occur through the sudden venting of the pneumatic actuator or pneumatic valve accessories not fitted with noise-reducing fittings. Both can damage hearing.

- Wear hearing protection when working near the valve.

⚠ WARNING

Crush hazard arising from actuator and plug stem moving.

- Do not insert hands or finger into the yoke while the air supply is connected to the actuator.
- Before working on the control valve, disconnect and lock the pneumatic air supply as well as the control signal.
- Do not impede the movement of the actuator and plug stem by inserting objects into the yoke.
- Before unblocking the actuator and plug stem after they have become blocked (e.g. due to seizing up after remaining in the same position for a long time), release any stored energy in the actuator (e.g. spring compression). See associated actuator documentation.

⚠ WARNING

Risk of personal injury due to exhaust air being vented from pneumatic devices.

While the valve is operating, the pneumatic actuator may vent during closed-loop control or when the valve opens or closes.

- Wear eye protection when working in close proximity to the control valve.

Operation

The operating instructions only apply in conjunction with the actuator. Refer to the corresponding mounting and operating instructions.

8 Malfunctions

Read hazard statements, warnings and caution notes in the 'Safety instructions and measures' section.

8.1 Troubleshooting

Malfunction	Possible reasons	Recommended action
Actuator and plug stem does not move on demand.	Actuator is blocked.	Check attachment. Remove the blockage. WARNING! A blocked actuator or plug stem (e.g. due to seizing up after remaining in the same position for a long time) can suddenly start to move uncontrollably. Injury to hands or fingers is possible if they are inserted into the actuator or valve. Before trying to unblock the actuator or plug stem, disconnect and lock the pneumatic air supply as well as the control signal. Before unblocking the actuator, release any stored energy in the actuator (e.g. spring compression). See associated actuator documentation.
	Pneumatic actuators: diaphragm in the actuator defective	See associated actuator documentation.
	Pneumatic actuators: signal pressure too low	Check the signal pressure. Check the signal pressure line for leakage.
	Electric actuators: no or incorrect supply voltage connected	Check the supply voltage and connections.
Actuator and plug stem does not stroke through the entire range.	Pneumatic actuators: signal pressure too low	Check the signal pressure. Check the signal pressure line for leakage.
	Electric actuators: no or incorrect supply voltage connected	Check the supply voltage and connections.
Increased flow through closed valve (seat leakage)	Dirt or other foreign particles deposited between the seat and plug.	Shut off the section of the pipeline and flush the valve.
	Valve trim is worn out.	Replace the seat and plug (see the 'Servicing' section).

Malfunctions

Malfunction	Possible reasons	Recommended action
The valve leaks to the atmosphere (fugitive emissions).	Metal bellows and packing defective	Replace metal bellows and packing of the plug stem (see the 'Servicing' section).
	Flange joint loose or gasket worn out	Check the flange joint. Replace the gasket on the flanged joint.

i Note

Contact our after-sales service for malfunctions not listed in the table.

8.2 Emergency action

The valve, on which the actuator with fail-safe action is mounted, is moved to its fail-safe position upon failure of the supply voltage or signal pressure (see the associated actuator documentation).

Plant operators are responsible for emergency action to be taken in the plant.

In the event of a valve malfunction:

1. Close the shut-off valves upstream and downstream of the control valve to stop the process medium from flowing through the valve.
2. Perform troubleshooting (see section 8.1).
3. Rectify those malfunctions that can be remedied based on the instructions provided here. Contact our after-sales service in all other cases.

Putting the valve back into operation after a malfunction

See the 'Start-up' section.

9 Servicing

The work described in this section is only to be performed by personnel appropriately qualified to carry out such tasks.

The following documents are also required for servicing the valve:

- Mounting and operating instructions for the mounted actuator, e.g. ▶ EB 8317 for SAMSON's Type 3371 Pneumatic Actuator
 - ▶ EB 8313 for SAMSON Type 3372 Pneumatic or Electropneumatic Actuator
 - ▶ EB 8331-X for SAMSON Type 3374 Electric Actuator
 - ▶ EB 5824-X for SAMSON Type 5824 Electric Actuator
 - ▶ EB 5827-X for SAMSON Type 5827 Electric Actuator

⚠ DANGER

Risk of bursting due to incorrect opening of pressurized equipment or components.

Valves and pipelines are pressure equipment that may burst when handled incorrectly.

Flying projectile fragments or the release of process medium under pressure can cause serious injury or even death.

Before working on the control valve:

- Depressurize all plant sections affected and the valve (including the actuator). Release any stored energy.
- Drain the process medium from all the plant sections concerned as well as the valve.

⚠ WARNING

Risk of burn injuries due to hot or cold components and pipeline.

Valve components and the pipeline may become very hot or cold. Risk of burn injuries.

- Allow components and pipelines to cool down or warm up to the ambient temperature.
- Wear protective clothing and safety gloves.

⚠ WARNING

Risk of hearing loss or deafness due to loud noise.

Noise emission (e.g. cavitation or flashing) may occur during operation caused by the process medium and the operating conditions. Additionally, a loud noise may briefly occur through the sudden venting of the pneumatic actuator or pneumatic valve accessories not fitted with noise-reducing fittings. Both can damage hearing.

- Wear hearing protection when working near the valve.

⚠ WARNING

Crush hazard arising from actuator and plug stem moving.

- Do not insert hands or finger into the yoke while the air supply is connected to the actuator.
- Before working on the control valve, disconnect and lock the pneumatic air supply as well as the control signal.

Servicing

- Do not impede the movement of the actuator and plug stem by inserting objects into the yoke.
- Before unblocking the actuator and plug stem after they have become blocked (e.g. due to seizing up after remaining in the same position for a long time), release any stored energy in the actuator (e.g. spring compression). See associated actuator documentation.

⚠ WARNING

Risk of personal injury due to exhaust air being vented from pneumatic devices.

While the valve is operating, the pneumatic actuator may vent during closed-loop control or when the valve opens or closes.

- Wear eye protection when working in close proximity to the control valve.

⚠ WARNING

Risk of personal injury due to preloaded springs in pneumatic actuators.

Actuators with preloaded springs are under tension. They can be identified by the long bolts protruding from the bottom of the actuator.

- Before starting any work on the actuator, relieve the compression from the preloaded springs (see associated actuator documentation).

⚠ WARNING

Risk of personal injury due to residual process medium in the valve.

While working on the valve, residual medium can flow out of the valve and, depending on its properties, cause personal injury, e.g. (chemical) burns.

- Wear protective clothing, safety gloves, respiratory protection and eye protection.

ⓘ NOTICE

Risk of valve damage due to excessively high or low tightening torques.

Observe the specified torques when tightening control valve components. Excessive tightening torques lead to parts wearing out more quickly. Parts that are too loose may cause leakage.

- Observe the specified tightening torques.

ⓘ NOTICE

Risk of valve damage due to the use of unsuitable tools.

- Only use tools approved by SAMSON.

ⓘ NOTICE

Risk of valve damage due to the use of unsuitable lubricants.

- Only use lubricants approved by SAMSON.

i Note

The control valve was checked by SAMSON before it left the factory.

- Certain test results certified by SAMSON lose their validity when the valve is opened. Such testing includes seat leakage and leak tests.
- The product warranty becomes void if service or repair work not described in these instructions is performed without prior agreement by SAMSON's After-sales Service.
- Only use original spare parts by SAMSON, which comply with the original specifications.

9.1 Periodic testing

Depending on the operating conditions, check the valve at certain intervals to prevent possible failure before it can occur. Plant operators are responsible for drawing up an inspection and test plan.

💡 Tip

Our after-sales service can support you in drawing up an inspection and test plan for your plant.

9.2 Preparing the valve for service work

1. Lay out the necessary material and tools to have them ready for the service work.
2. Put the control valve out of operation (see the 'Decommissioning' section).

3. Remove the actuator from the valve. Unscrew the screws on the stem connector (7) and the nut (9). Lift the actuator off the valve.

💡 Tip

We recommend removing the valve from the pipeline before performing any service work (see the 'Removal' section).

The following service work can be performed after preparation is completed:

- Replace the metal bellows (see section 9.4.1)
- Replace the seat and plug (see section 9.4.2)

9.3 Installing the valve after service work

1. Mount actuator. See associated actuator documentation and the 'Installation' section.
2. Adjust lower or upper signal bench range. See associated actuator documentation.
3. If the valve has been removed, re-install the valve into the pipeline (see the 'Installation' section).
4. Put the control valve back into operation (see the 'Start-up' section). Observe the requirements and conditions for start-up or putting the valve back into operation.

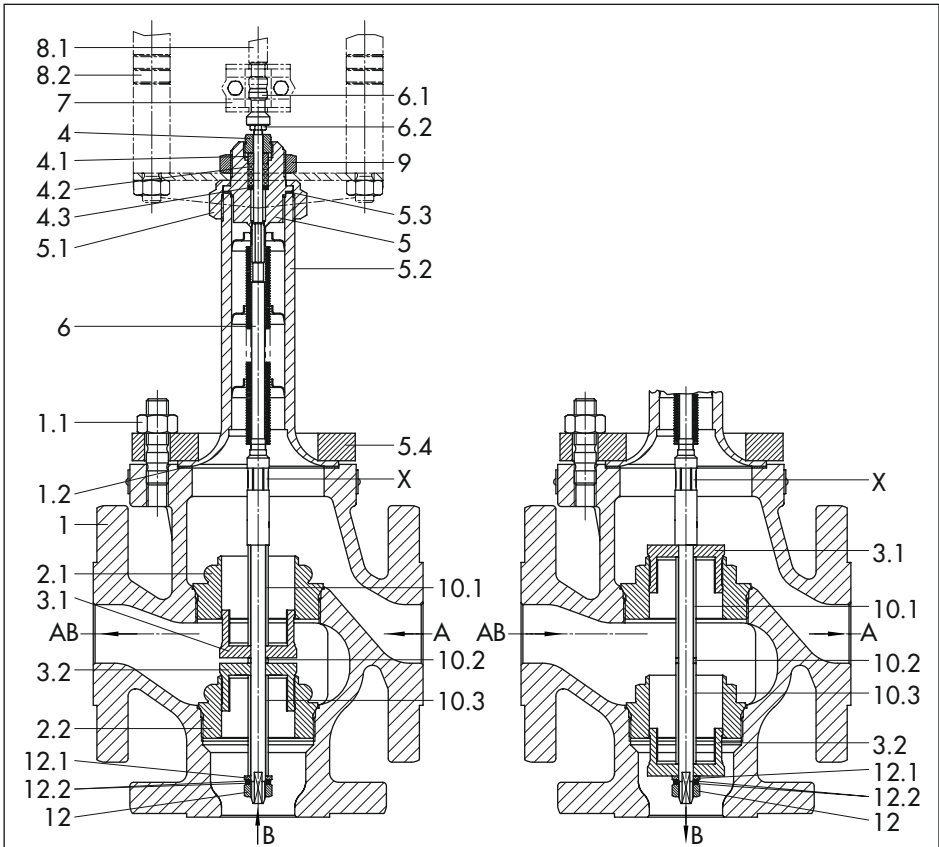

Fig. 9-1: Sectional drawing DN 32 to 50, plug arrangement for mixing valve (left) and diverting valve (right)

1	Valve body	4.3	Washer	8.1	Actuator stem
1.1	Nuts	5	Bellows seal with plug stem	8.2	Rod-type yoke
1.2	Gasket	5.1	Coupling nut	9	Nut
2.1	Top seat	5.2	Bellows housing	10.1	Sleeve
2.2	Bottom seat	5.3	Gasket	10.2	Short sleeve
3.1	Top plug	5.4	Flange	10.3	Sleeve
3.2	Bottom plug	6	Plug stem	12	Nut
4	Threaded bushing	6.1	Stem connector nut	12.1	Washer
4.1	Bushing	6.2	Lock nut	12.2	Retaining washers
4.2	Packing (spring-loaded for DN 65 and larger)	7	Stem connector	X	Position for open-end wrench

9.4 Service work

- Before performing any service work, preparations must be made to the control valve (see section 9.2).
- We recommend thoroughly cleaning removed parts and, if necessary, replacing them with new ones.
- After all service work is completed, check the control valve before putting it back into operation (see 'Testing the installed valve' in the 'Installation' section).

9.4.1 Replacing the metal bellows

If the packing leaks, this is due to a defective bellows seal. In this case, the entire bellows seal assembly must be replaced together with the packing (4.2).

We recommend renewing the top gasket (5.3) and bottom gasket (1.2) at the bellows housing as well.

Mixing and diverting valves in DN 32 to 80 differ in the arrangement of their plugs and sleeves (see Fig. 9-1). Valves in DN 15 to 25 have the same plug and sleeve arrangement.

Disassembly

1. In valves \leq DN 50, unscrew the lock nut (6.2) and stem connector nut (6.1) from the plug stem.
2. Unscrew the coupling nut (5.1) from the bellows housing.
3. Remove nuts (1.1) and lift off the flange (5.4).

4. Pull out the bellows housing (5.2) and bellows seal as far as they will go. Place an open-end wrench SW 10 (\leq DN 50) or SW 13 (\geq DN 65) at the side on the hex (X) or at the flattened area of the plug stem to hold the stem stationary. Loosen the nut (12) and remove the wrench.
5. Unscrew the nut (12). Remove the two retaining washers (12.2) and washer (12.1).

6. DN 15 to 25

- Carefully pull the plug stem (6) together with the bellows seal (5) and bellows housing (5.2) out of the body from above.

DN 32 to 80

- Keep hold of the bottom plug of diverting valves or the bottom sleeve of mixing valves on the plug stem. Use a long screw (M8 for DN 32 to 50 and M12 for DN 65 and 80) to keep the plugs (3.x) and sleeves (10.x) in the right position.
 - Carefully pull the plug stem together with the bellows seal (5) and bellows housing (5.2) out of the body from above.
 - Guide the screw (to hold the plugs and sleeves) into the valve body and push upwards, allowing the plugs and sleeves to slide onto the screw.
7. Carefully clean all the parts and check them for damage. Replace the plug stem together with the bellows seal and packing with new parts.

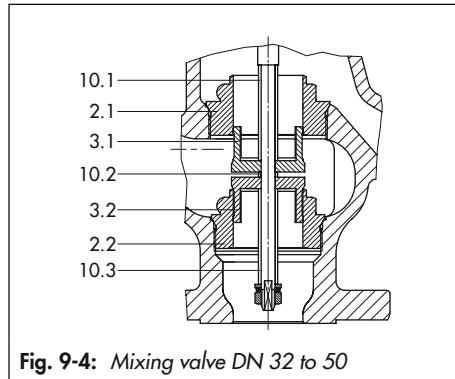
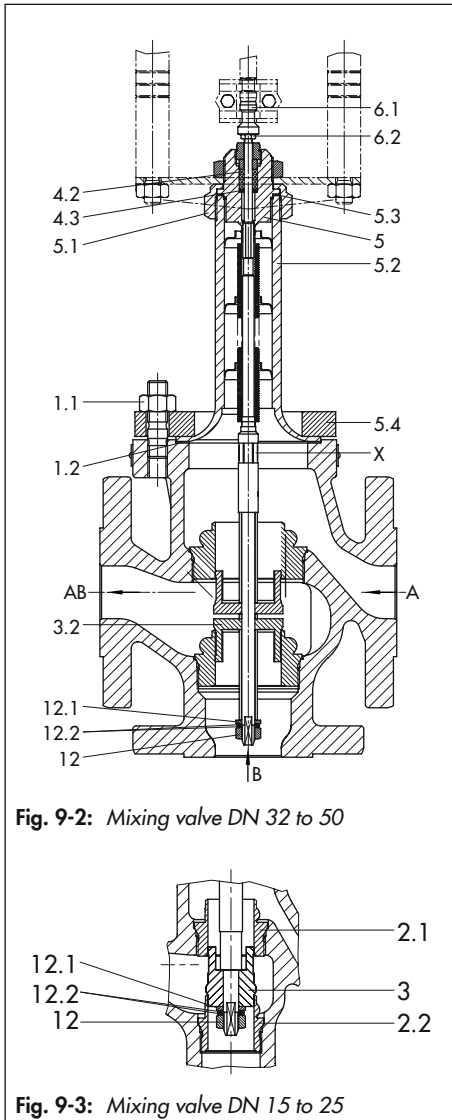

Assembly

1. Apply a suitable lubricant to the gasket (5.3) and thread on the bellows housing.
2. Insert the gasket (5.3) on the bellows housing (5.2).
3. Push the bellows seal (5) together with the plug stem into the bellows housing. Tighten the coupling nut (5.1) by hand only at first.
4. Insert the gasket (1.2) into the valve body.

5. DN 15 to 25

- Place the ready-assembled bellows seal assembly on the valve body, while guiding the plug stem through the holes in the plug.

DN 32 to 80

- Gradually insert the plug stem of the ready-assembly bellows seal assembly (5) into the valve body, allowing the plugs and sleeves to slide from the screw (used to hold the plugs and sleeves) onto the plug stem.

6. First place the washer (12.1) and then the pair of serrated retaining washers (12.2) onto the plug stem, making sure the coarsely serrated surfaces of the retaining washers face each other and the radial ribs face outwards. Thread the nut (12) onto the plug stem by hand.

i Note

For valves in DN 15 to 50, a special tool designed to hold the washers (12.1 and 12.2) can be ordered from our after-sales service (see the 'Tools and tightening torques' section in the annex of these instructions). Especially on valves in DN 15 to 25, it is difficult to mount the washers onto the plug stem due to insufficient space.

7. Slightly pull out the bellows housing (5.2) together with the bellows seal. Place an open-end wrench at the side on the hex or at the flattened area (X) of the plug stem to hold the stem stationary.

ⓘ NOTICE

Risk of leakage due damage of the metal bellows.

→ *While mounting the bellows, make sure that no torque is transferred to the metal bellows.*

8. Tighten the nut (12) to secure the plugs and the sleeves:

Valve size	15 to 50	65 to 80
Nut (12)	15 Nm	25 Nm

9. Remove the open-end wrench.

10. Place on the flange (5.4) and align it with the bellows housing (5.2), while making sure the gasket (1.2) is correctly positioned.

11. Fasten the nuts (1.1):

Valve size	15 to 25	32 to 50	65 to 80
Nuts (1.1)	M10 10 Nm	M12 30 Nm	M16 90 Nm

Tighten the coupling nut (5.1) with 80 Nm tightening torque.

12. For DN 15 to 50, thread the lock nut (6.2) and stem connector nut (6.1) onto the top end of the plug stem again. Adjust the stem connector nut (6.1) to keep the dimension of 50 mm from the top of the bellows seal assembly (5) to the top of the stem connector nut (6.1) after the plug stem has been pushed completely into the valve (see the dimensional drawing in the 'Design and principle of operation' section).

9.4.2 Replacing the seat and plug

i Note

When replacing the seat and/or plug, we recommend renewing the gaskets (5.3, 1.2) at the top and bottom of the bellows housing as well.

a) Mixing valve

Disassembly

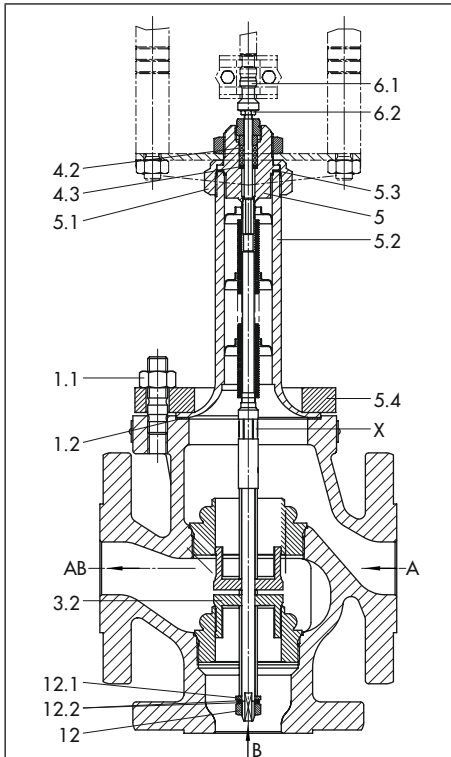

Fig. 9-5: Mixing valve DN 32 to 50

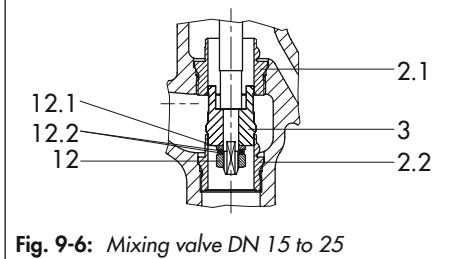

Fig. 9-6: Mixing valve DN 15 to 25

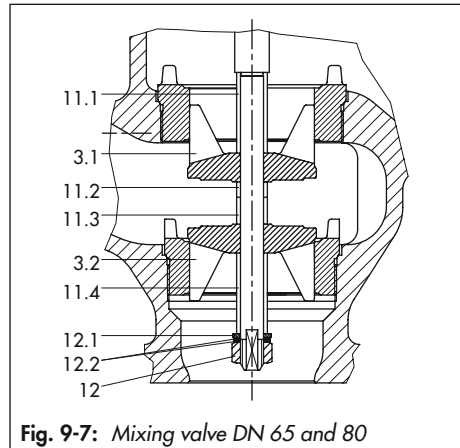

Fig. 9-7: Mixing valve DN 65 and 80

1. In valves \leq DN 50, unscrew the lock nut (6.2) and stem connector nut (6.1) from the plug stem.
 2. Unscrew the coupling nut (5.1) from the bellows housing. Remove nuts (1.1) and lift off the flange (5.4).
 3. Pull out the bellows housing (5.2) and bellows seal as far as they will go. Place an open-end wrench SW 10 (\leq DN 50) or SW 13 (\geq DN 65) at the side on the hex (X) or at the flattened area of the plug stem to hold the stem stationary. Loosen the nut (12) and remove the wrench.
 4. Unscrew the nut (12). Remove the two retaining washers (12.2) and washer (12.1).
- Mixing valves (DN 32 to 80):**
Pull bottom sleeve (10.3 or 11.4) off the plug stem.
 5. Lift the bellows housing (5.2) together with the bellows seal (5) and carefully

- pull the plug stem (6) out of the valve body.
6. Pull the bellows seal (5) out of the bellows housing and remove the body gasket (1.2).
 7. Carefully clean all the parts and check them for damage. Renew defective parts.
 8. **Valves \geq DN 32:**
 - Remove sleeve (10.1 or 11.1).
 - Unscrew the top seat (2.1) using a suitable seat wrench (see the 'Tools and tightening torques' section in the annex of these instructions).
 9. **DN 15 to 25**
 - Remove the plug (3) from the valve body.**DN 32 to 50**
 - Remove the top plug (3.1), sleeve (10.2) and bottom plug (3.2) from the valve body.**DN 65/80**
 - Remove the top plug (3.1), sleeves (11.2 and 11.3) and bottom plug (3.2) from the valve body.
 10. Unscrew the bottom seat (2.2) from the valve body.
 11. Carefully clean all the parts. Check and renew them, if necessary.

Assembly

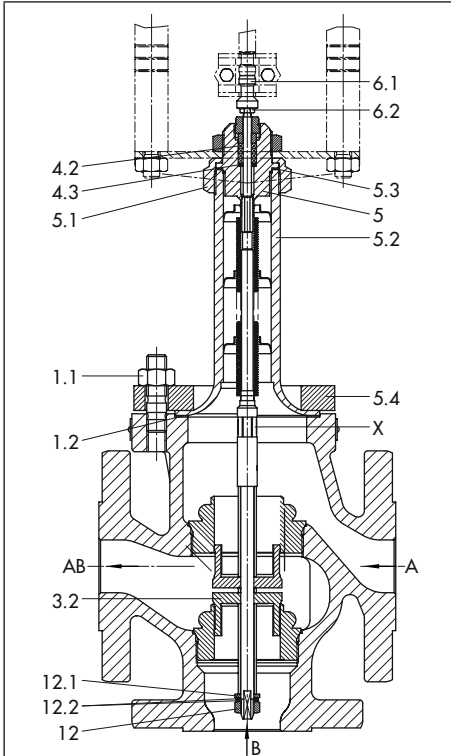

Fig. 9-8: Mixing valve DN 32 to 50

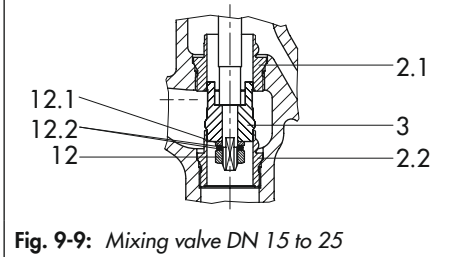

Fig. 9-9: Mixing valve DN 15 to 25

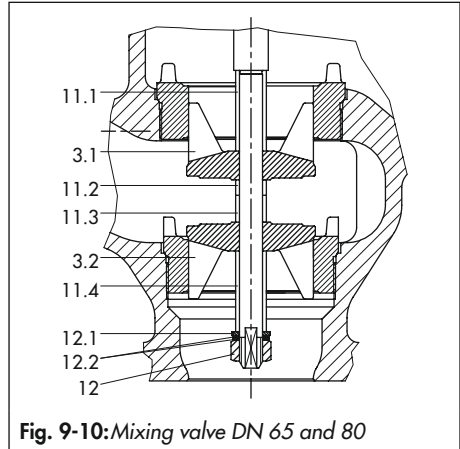

Fig. 9-10: Mixing valve DN 65 and 80

1. Apply a suitable lubricant to the gasket (5.3) and thread on the bellows housing.
2. Insert the gasket (5.3) on the bellows housing (5.2).
3. Push the bellows seal (5) together with the plug stem into the bellows housing. Tighten the coupling nut (5.1) by hand only at first.
4. Apply a suitable lubricant to the thread and the sealing cone of the new or machined seats.
5. Use the seat wrench to screw in the bottom seat (2.2), observing the correct tightening torques:

Valve size	15...25	32...50	65...80
Seat thread	M32x1.5	M58x1.5	M90x1.5
Tightening torque	120 Nm	500 Nm	1050 Nm

6. **DN 15 to 25**

- Insert the plug (3) into the bottom seat (2.2).

DN 32 to 50

- Insert the bottom plug (3.2) into the bottom seat (2.2).
- Place the short sleeve (10.2) and top plug (3.1) one after the other onto the bottom plug. To fix them into position, insert a long M8 screw through the bottom plug.

DN 65/80

- Insert the bottom plug (3.2) into the bottom seat (2.2).
- Place the two short sleeves (11.3 and 11.2) and top plug (3.1) one after the other onto the bottom plug. To fix them into position, insert a long M12 screw through the bottom plug.

7. Screw the top seat (2.1) into the body, ensuring that the top plug can easily slide into the seat. Refer to table in step 5 for the correct tightening torque.

8. Insert the gasket (1.2) into the top valve flange.

9. **DN 15 to 25**

- Carefully place the bonnet onto the valve, while guiding the plug stem into the plug (3).

DN 32 to 50

- Slide the sleeve (10.1) over the plug stem. Carefully place on the bonnet, while guiding the plug stem through the top plug (3.1), sleeve (10.2) and bottom plug (3.2) and, at the same time, remove the M8 screw.

- Slide the sleeve (10.3) onto the plug stem from underneath.

DN 65 and 80

- Slide the sleeve (11.1) over the plug stem. Carefully place on the bonnet, while guiding the plug stem through the top plug (3.1), two sleeves (11.2 and 10.3) and bottom plug (3.2) into the body and, at the same time, remove the M12 screw.
- Slide the sleeve (11.4) onto the plug stem from underneath.

10. First place the washer (12.1) and then the pair of serrated retaining washers (12.2) onto the plug stem, making sure the coarsely serrated surfaces of the retaining washers face each other and the radial ribs face outwards. Thread the nut (12) onto the plug stem by hand.

i Note

For valves in DN 15 to 50, a special tool designed to hold the washers (12.1 and 12.2) can be ordered from our after-sales service (see the 'Tools and tightening torques' section in the annex of these instructions). Especially on valves in DN 15 to 25, it is difficult to mount the washers onto the plug stem due to insufficient space.

11. Slightly pull out the bellows housing (5.2) together with the bellows seal. Place an open-end wrench at the side on the hex or at the flattened area (X) of the plug stem to hold the stem stationary.

NOTICE

Risk of leakage due damage of the metal bellows.

→ While mounting the bellows, make sure that no torque is transferred to the metal bellows.

12. Tighten the nut (12) to secure the plugs and the sleeves:

Valve size	15...50	65...80
Nut (12)	15 Nm	25 Nm

13. Remove the open-end wrench.

14. Place on the flange (5.4) and align it with the bellows housing (5.2), while making sure the gasket (1.2) is correctly positioned.

15. Fasten the nuts (1.1):

Valve size	15...25	32...50	65...80
Nuts (1.1)	M10 10 Nm	M12 30 Nm	M16 90 Nm

– Tighten the coupling nut (5.1) with 80 Nm tightening torque.

16. For DN 15 to 50, thread the lock nut (6.2) and stem connector nut (6.1) onto the top end of the plug stem again. Adjust the stem connector nut (6.1) to keep the dimension of 50 mm from the top of the bellows seal assembly (5) to the top of the stem connector nut (6.1) after the plug stem has been pushed completely into the valve (see the dimensional drawing in the 'Design and principle of operation' section).

b) Diverting valve

Disassembly

1. In valves \leq DN 50, unscrew the lock nut (6.2) and stem connector nut (6.1) from the plug stem.
2. Unscrew the coupling nut (5.1) from the bellows housing. Remove nuts (1.1) and lift off the flange (5.4).
3. Pull out the bellows housing (5.2) and bellows seal as far as they will go. Place an open-end wrench SW 10 (\leq DN 50) or SW 13 (\geq DN 65) at the side on the hex (X) or at the flattened area of the plug stem to hold the stem stationary. Loosen the nut (1.2) and remove the wrench.
4. Unscrew the nut (1.2). Remove the two retaining washers (12.2) and washer (12.1).
5. Pull the bellows seal (5) out of the bellows housing and remove the body gasket (1.2).
6. Carefully clean all the parts and check them for damage. Renew defective parts.
7. **DN 15 to 25**
 - Unscrew the top seat (2.1). Remove the plug (3) from the valve body. Take out the bottom seat (2.2).

DN 32 to 50

- Remove the top plug (3.1) and the three sleeves (10.1, 10.2, 10.3) from the valve body.

DN 65/80

- Remove the top plug (3.1) and the four sleeves (11.1, 11.2, 11.3, 11.4) from the valve body.

8. DN 32 to 80

- Unscrew the top and bottom seat (2.1, 2.2) using a suitable seat wrench (see the 'Tools and tightening torques' section in the annex of these instructions) from the valve body.
 - Remove the bottom plug (3.2) from the valve body.
9. Carefully clean all the parts and check them. If necessary, renew or machine them.

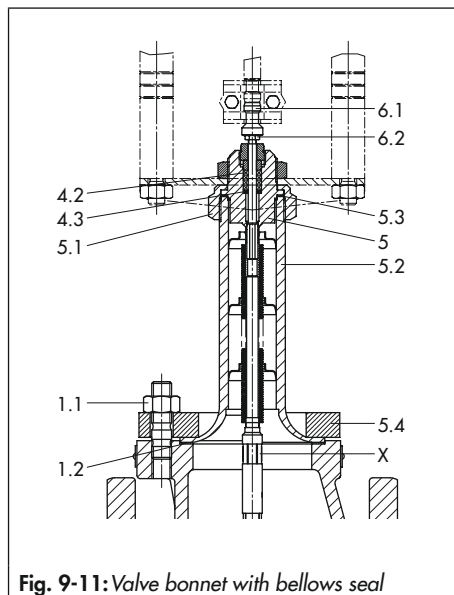

Fig. 9-11: Valve bonnet with bellows seal

Assembly

1. Apply a suitable lubricant to the gasket (5.3) and thread on the bellows housing.
2. Place on the gasket (5.3) and push the bellows seal (5) together with the plug stem into the bellows housing (5.2). Tighten the coupling nut (5.1) by hand at first.
3. Apply a suitable lubricant to the thread and the sealing cone of the new or machined seat.

4. DN 15 to 25

- Screw in the bottom seat (2.2) and tighten:

Valve size	15...25
Seat thread	M32x1.5
Tightening torque	120 Nm

- Place the plug (3) in the bottom seat. Screw in the top seat (2.1), ensuring that the plug can slide into the seat

from underneath. Tighten the top seat with the same tightening torque.

DN 32 to 50

- Insert the bottom seat (3.2) into the valve body. Use the seat wrench to screw in the bottom seat (2.2) and top seat (2.1) one after the other.

Valve size	32...50
Seat thread	M58x1.5
Tightening torque	500 Nm

- Place the top plug (3.1) and three sleeves (10.1, 10.2, 10.3) onto the plug stem one after the other.

DN 65 and 80

- Insert the bottom seat (3.2) into the valve body. Use the seat wrench to screw in the bottom seat (2.2) and top seat (2.1) one after the other:

Valve size	65 and 80
Seat thread	M90x1.5
Tightening torque	1050 Nm

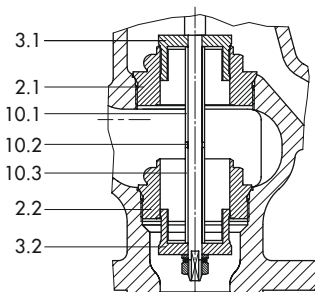

Fig. 9-12: Diverting valve DN 32 to 50

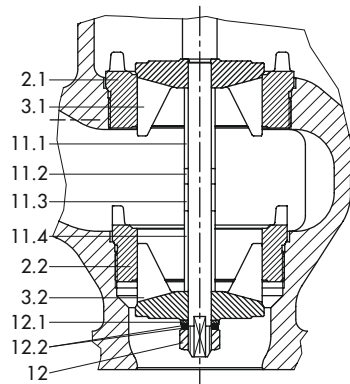

Fig. 9-13: Diverting valve DN 65 and 80

- Place the top plug (3.1) and four sleeves (11.1, 11.2, 11.3, 11.4) onto the plug stem one after the other.
5. For diverting valves in DN 32 and larger, insert the bottom plug into the bottom seat.
 - Insert the gasket (1.2) into the body flange. Carefully guide the plug stem (6) into the bellows housing (5.2).
 - Hold the bottom plug in the seat to push the plug stem in the middle through the plug bore.
 6. First place the washer (12.1) and then the pair of serrated retaining washers (12.2) onto the plug stem, making sure the coarsely serrated surfaces of the retaining washers face each other and the radial ribs face outwards. Thread the nut (12) onto the plug stem by hand.

i Note

For valves in DN 15 to 50, a special tool designed to hold the washers (12.1 and 12.2) can be ordered from our after-sales service (see the 'Tools and tightening torques' section in the annex of these instructions). Especially on valves in DN 15 to 25, it is difficult to mount the washers onto the plug stem due to insufficient space.

7. Slightly pull out the bellows housing (5.2) together with the bellows seal. Place an open-end wrench at the side on the hex (X) or at the flattened area of the plug stem to hold the stem stationary.

! NOTICE

Risk of leakage due damage of the metal bellows.

➔ *While mounting the bellows, make sure that no torque is transferred to the metal bellows.*

8. Tighten the nut (12) to secure the plugs and the sleeves:

Valve size	15...50	65...80
Nut (12)	15 Nm	25 Nm

9. Remove the open-end wrench.
10. Place on the flange (5.4) and align it with the bellows housing (5.2), while making sure the gasket (1.2) is correctly positioned.
11. Fasten the nuts (1.1):

Valve size	15...25	32...50	65...80
Nuts (1.1)	M10 10 Nm	M12 30 Nm	M16 90 Nm

- Tighten the coupling nut (5.1) with 80 Nm tightening torque.
12. For DN 15 to 50, thread the lock nut (6.2) and stem connector nut (6.1) onto the top end of the plug stem again. Adjust the stem connector nut (6.1) to keep the dimension of 50 mm from the top of the bellows seal assembly (5) to the top of the stem connector nut (6.1) after the plug stem has been pushed completely into the valve (see the dimensional drawing in the 'Design and principle of operation' section).

9.5 Ordering spare parts and operating supplies

Contact your nearest SAMSON subsidiary or SAMSON's After-sales Service for information on spare parts, lubricants and tools.

Tools

See Annex for details on suitable tools.

10 Decommissioning

The work described in this section is only to be performed by personnel appropriately qualified to carry out such tasks.

⚠ DANGER

Risk of bursting due to incorrect opening of pressurized equipment or components.

Valves and pipelines are pressure equipment that may burst when handled incorrectly.

Flying projectile fragments or the release of process medium under pressure can cause serious injury or even death.

Before working on the control valve:

- Depressurize all plant sections affected and the valve (including the actuator). Release any stored energy.
- Drain the process medium from all the plant sections concerned as well as the valve.

⚠ DANGER

Risk of fatal injury due to electric shock.

- Do not remove any covers to perform adjustment work on live parts.
- Before performing any work on the device and before opening the device, disconnect the supply voltage and protect it against unintentional reconnection.
- Only use power interruption devices that are protected against unintentional reconnection of the power supply.

⚠ WARNING

Risk of burn injuries due to hot or cold components and pipeline.

Valve components and the pipeline may become very hot or cold. Risk of burn injuries.

- Allow components and pipelines to cool down or warm up to the ambient temperature.
- Wear protective clothing and safety gloves.

⚠ WARNING

Risk of hearing loss or deafness due to loud noise.

Noise emission (e.g. cavitation or flashing) may occur during operation caused by the process medium and the operating conditions. Additionally, a loud noise may briefly occur through the sudden venting of the pneumatic actuator or pneumatic valve accessories not fitted with noise-reducing fittings. Both can damage hearing.

- Wear hearing protection when working near the valve.

⚠ WARNING

Crush hazard arising from actuator and plug stem moving.

- Do not insert hands or finger into the yoke while the air supply is connected to the actuator.
- Before working on the control valve, disconnect and lock the pneumatic air supply as well as the control signal.

Decommissioning

- Do not impede the movement of the actuator and plug stem by inserting objects into the yoke.
 - Before unblocking the actuator and plug stem after they have become blocked (e.g. due to seizing up after remaining in the same position for a long time), release any stored energy in the actuator (e.g. spring compression). See associated actuator documentation.
-

WARNING

Risk of personal injury due to exhaust air being vented from pneumatic devices.

While the valve is operating, the pneumatic actuator may vent during closed-loop control or when the valve opens or closes.

- Wear eye protection when working in close proximity to the control valve.
-

WARNING

Risk of personal injury due to residual process medium in the valve.

While working on the valve, residual medium can flow out of the valve and, depending on its properties, cause personal injury, e.g. (chemical) burns.

- Wear protective clothing, safety gloves, respiratory protection and eye protection.
-

To decommission the control valve for service work or to remove it from the pipeline, proceed as follows:

1. Close the shut-off valves upstream and downstream of the control valve to stop the process medium from flowing through the valve.
2. Completely drain the pipelines and valve.
3. Disconnect and lock the pneumatic air supply or supply voltage to depressurize or de-energize the actuator.
4. Release any stored energy.
5. If necessary, allow the pipeline and valve components to cool down or warm up to the ambient temperature.

11 Removal

The work described in this section is only to be performed by personnel appropriately qualified to carry out such tasks.

⚠ WARNING

Risk of burn injuries due to hot or cold components and pipeline.

Valve components and the pipeline may become very hot or cold. Risk of burn injuries.

- Allow components and pipelines to cool down or warm up to the ambient temperature.
- Wear protective clothing and safety gloves.

⚠ WARNING

Crush hazard arising from actuator and plug stem moving.

- Do not insert hands or finger into the yoke while the air supply is connected to the actuator.
- Before working on the control valve, disconnect and lock the pneumatic air supply as well as the control signal.
- Do not impede the movement of the actuator and plug stem by inserting objects into the yoke.
- Before unblocking the actuator and plug stem after they have become blocked (e.g. due to seizing up after remaining in the same position for a long time), release any stored energy in the actuator (e.g. spring compression). See associated actuator documentation.

⚠ WARNING

Risk of personal injury due to residual process medium in the valve.

While working on the valve, residual medium can flow out of the valve and, depending on its properties, cause personal injury, e.g. (chemical) burns.

- Wear protective clothing, safety gloves, respiratory protection and eye protection.

⚠ WARNING

Risk of personal injury due to preloaded springs in pneumatic actuators.

Actuators with preloaded springs are under tension. They can be identified by the long bolts protruding from the bottom of the actuator.

- Before starting any work on the actuator, relieve the compression from the preloaded springs.

Before removing the valve, make sure the following conditions are met:

- The control valve is put out of operation (see the 'Decommissioning' section).

11.1 Removing the valve from the pipeline

1. Support the valve to hold it in place when separated from the pipeline (see the 'Shipment and on-site transport' section).
2. Unbolt the flange joint.

Removal

3. Remove the valve from the pipeline (see the 'Shipment and on-site transport' section).

11.2 Removing the actuator from the valve

See associated actuator documentation.

12 Repairs

If the valve does not function properly according to how it was originally sized or does not function at all, it is defective and must be repaired or exchanged.

! NOTICE

Risk of valve damage due to incorrect service or repair work.

- ➔ Do not perform any repair work on your own.
- ➔ Contact SAMSON's After-sales Service for repair work.

12.1 Returning devices to SAMSON

Defective devices can be returned to SAMSON for repair.

Proceed as follows to return devices:

1. Exceptions apply concerning some special device models
 - ▶ www.samsongroup.com > Service & Support > After-sales Service.
2. Send an e-mail
 - ▶ retouren@samsongroup.com to register the return shipment including the following information:
 - Type
 - Article no.
 - Configuration ID
 - Original order

- Completed Declaration on Contamination, which can be downloaded from our website at
 - ▶ www.samsongroup.com > Service & Support > After-sales Service.

After checking your registration, we will send you a return merchandise authorization (RMA).

3. Attach the RMA (together with the Declaration on Decontamination) to the outside of your shipment so that the documents are clearly visible.
4. Send the shipment to the address given on the RMA.

i Note

Further information on returned devices and how they are handled can be found at

- ▶ www.samsongroup.com > Service & Support > After-sales Service.

13 Disposal

- Observe local, national and international refuse regulations.
- Do not dispose of components, lubricants and hazardous substances together with your household waste.

14 Certificates

The declaration of conformity in accordance with Pressure Equipment Directive 2014/68/EU is provided on the next pages:

The certificates shown were up to date at the time of publishing. The latest certificates can be found on our website:

▶ www.samsongroup.com > *Products & Applications* > *Product selector* > *Valves* > *3535*

Other optional certificates are available on request.



EU-KONFORMITÄTSERKLÄRUNG EU DECLARATION OF CONFORMITY

Modul H/Module H, Nr./No. / N° CE-0062-PED-H-SAM 001-20-DEU

SAMSON erklärt in alleiniger Verantwortung für folgende Produkte:/For the following products, SAMSON hereby declares under its sole responsibility:

Ventile für elektrische und pneumatische Antriebe/Globe and three-way valves equipped with electric and pneumatic actuators

Typ/Type 3213, 3222 (Erz.-Nr./Model No. 2710), 3226, 3260* (2713*), 3323, 3535 (2803), 3213, 3531 (2811), 3214 (2814), 2423E (2823), 3241, 3244, 3267, 2422 (2814)

die Konformität mit nachfolgender Anforderung/the conformity with the following requirement.

Richtlinie des Europäischen Parlaments und des Rates zur Harmonisierung der Rechtsvorschriften der Mitgliedstaaten über die Bereitstellung von Druckgeräten auf dem Markt. 2014/68/EU vom 15.05.2014

Directive of the European Parliament and of the Council on the harmonization of the laws of the Member States relating of the making available on the market of pressure equipment. 2014/68/EU of 15 May 2014

Angewandtes Konformitätsbewertungsverfahren für Fluide nach Art. 4(1)(c.ii) und (c.i) zweiter Gedankenstrich. Modul siehe Tabelle durch certified by Bureau Veritas Services SAS. (0062)

Conformity assessment procedure applied for fluids according to Article 4(1)(c.ii) and (c.i), second indent See table for module

Nenndruck Pressure rating	DN NPS	15 ½	20 ¾	25 1	32 1¼	40 1½	50 2	65	80 3	100 4	125	150 6	200 8	250 10	300 12	400 16
PN 16		ohne/without (1)					A (2)(3)					H				
PN 25		ohne/without (1)					A (2)(3)					H				
PN 40		ohne/without (1)					A (2)(3)					H				
Class 150		ohne/without (1)					A (2)(3)					H				
Class 300		ohne/without (1)					A (2)(3)					H				

- (1) Das auf dem Stellgerät aufgebrachte CE-Zeichen hat keine Gültigkeit im Sinne der Druckgeräterichtlinie.
The CE marking affixed to the control valve is not valid in the sense of the Pressure Equipment Directive.
- (2) Das auf dem Stellgerät aufgebrachte CE-Zeichen gilt ohne Bezeichnung der benannten Stelle (Kenn-Nr. 0062).
The CE marking affixed to the control valve is valid without specifying the notified body (ID number 0062).
- (3) Die Identifikationsnummer 0062 von Bureau Veritas Services SAS gilt nicht für Modul A.
The identification number 0062 of Bureau Veritas Services SAS is not valid for module A.

* Für Ventile vom Typ 3260 sind ab DN 150 Fluide nach Art. 4(1)(c.ii) erster Gedankenstrich nicht zugelassen.
Fluids according to Art. 4(1)(c.ii), first indent are not permissible for Type 3260 Valves with DN equal or bigger than 150.

Geräte, denen laut Tabelle das Konformitätsbewertungsverfahren Modul H zugrunde liegt, beziehen sich auf die „Zulassungsbescheinigung eines Qualitätssicherungsystems“ ausgestellt durch die benannte Stelle.
Devices whose conformity has been assessed based on Module H refer to the certificate of approval for the quality management system issued by the notified body.

Dem Entwurf zu Grunde gelegt sind Verfahren aus/The design is based on the procedures specified in the following standards:
DIN EN 12516-2, DIN EN 12516-3 bzw./or ASME B16.1, ASME B16.24, ASME B16.34, ASME B16.42

Das Qualitätssicherungssystem des Herstellers wird von folgender benannter Stelle überwacht:

The manufacturer's quality management system is monitored by the following notified body:

Bureau Veritas Services SAS, 8 Cours du Triangle, 92800 PUTEAUX – LA DEFENSE, France
Hersteller/Manufacturer: SAMSON AG, Weismüllerstraße 3, 60314 Frankfurt am Main, Germany

Frankfurt am Main, 11. Mai 2020/11. May 2020

Thorsten Woth
Senior Director
Sales and After-sales

Peter Scheermesser
Director Central Department
Product maintenance, contract development and ETO for valves and actuators

SAMSON AKTIENGESELLSCHAFT
Weismüllerstraße 3 60314 Frankfurt am Main

Telefon: 069 4009-0 Telefax: 069 4009-1507
E-Mail: samson@samson.de Revision 04

EU-Konformitätserklärung_Blit-06_Modul-A_Modul-H_DE-EN_Rev.03_2017-02-08.docx



EU-KONFORMITÄTSERKLÄRUNG EU DECLARATION OF CONFORMITY

Modul H/Module H, Nr./No. / N° CE-0062-PED-H-SAM 001-20-DEU

SAMSON erklärt in alleiniger Verantwortung für folgende Produkte:/For the following products, SAMSON hereby declares under its sole responsibility:

Ventile für elektrische Stellgeräte und Strahlpumpe/Globe and three-way valves and jet pump equipped with electric actuators

Typ/Type 3213, 3222 (Erz.-Nr./Model No. 2710), 3323, 3535 (2803), 3213, 3531 (2811), 3214 (2814), 2423E (2823), 3241, 3244, 3267

die Konformität mit nachfolgender Anforderung / the conformity with the following requirement.

Richtlinie des Europäischen Parlaments und des Rates zur Harmonisierung der Rechtsvorschriften der Mitgliedstaaten über die Bereitstellung von Druckgeräten auf dem Markt. 2014/68/EU vom 15.05.2014

Directive of the European Parliament and of the Council on the harmonization of the laws of the Member States relating of the making available on the market of pressure equipment. 2014/68/EU of 15.05.2014

Angewandtes Konformitätsbewertungsverfahren für Fluide nach Art. 1(1)(c.i) erster Gedankenstrich. Modül siehe Tabelle durch certified by Bureau Veritas Services SAS (0062)
Conformity assessment procedure applied for fluids according to Article 4(1)(c.i), first indent. See table for module

Nenndruck Pressure rating	DN NPS	15 ½	20 ¾	25 1	32 1¼	40 1½	50 2	65 -	80 3	100 4	125 -	150 6	200 8	250 10	300 12	400 16
PN 25		ohne ⁽¹⁾			A ⁽²⁾⁽³⁾		H									
PN 40		ohne ⁽¹⁾					H									
Class 150		ohne ⁽¹⁾			A ⁽²⁾⁽³⁾		H									
Class 300		ohne ⁽¹⁾					H									

- Das auf dem Stellgerät aufgebrauchte CE-Zeichen hat keine Gültigkeit im Sinne der Druckgeräterichtlinie
The CE marking affixed to the control valve is not valid in the sense of the Pressure Equipment Directive.
- Das auf dem Stellgerät aufgebrauchte CE-Zeichen gilt ohne Bezeichnung der benannten Stelle (Kenn-Nr. 0062)
The CE marking affixed to the control valve is valid without specifying the notified body (ID number 0062).
- Die Identifikationsnummer 0062 von Bureau Veritas Services SAS gilt nicht für Modul A.
The identification number 0062 of Bureau Veritas Services SAS is not valid for module A.

Geräte, denen laut Tabelle das Konformitätsbewertungsverfahren Modul H zugrunde liegt, beziehen sich auf die „Zulassungsbescheinigung eines Qualitätssicherungssystems“ ausgestellt durch die benannte Stelle.

Devices whose conformity has been assessed based on Module H refer to the certificate of approval for the quality management system issued by the notified body.

Dem Entwurf zu Grunde gelegt sind Verfahren aus:/The design is based on the procedures specified in the following standards:

DIN EN 12516-2, DIN EN 12516-3 bzw./or ASME B16.24, ASME B16.34, ASME B16.42

Das Qualitätssicherungssystem des Herstellers wird von folgender benannter Stelle überwacht:

The Manufacturer's Quality Assurance System is monitored by following Notified Body

Bureau Veritas Services SAS, 8 Cours du Triangle, 92800 PUTEAUX – LA DEFENSE, France
Hersteller/Manufacturer: SAMSON AG, Weismüllerstraße 3, 60314 Frankfurt am Main, Germany

Frankfurt am Main, 11. Mai 2020/11. May 2020

Thorsten Muth
Senior Director
Sales and After-sales

i.V. P. Schermesser
Peter Schermesser
Director Central Department
Product maintenance, contract development and ETO for valves and actuators

SAMSON AKTIENGESELLSCHAFT
Weismüllerstraße 3 60314 Frankfurt am Main

Telefon: 069 4009-0 Telefax: 069 4009-1507
E-Mail: samson@samson.de

Revision 04

15 Annex

15.1 Tools and tightening torques

Valve size	DN 15 to 25 NPS ½ to 1	DN 32 to 50 NPS 1½ to 2	DN 65 to 80 NPS 2½ to 3
Seat wrench with material number	1280-3010	1280-3011	1280-0305
Holding tool	1280-3059 for washer (12.1) and anti-rotation fixture (12.2)		
Tightening torques (±10 %)			
Valve seat	120 Nm (M32x1.5)	500 Nm (M58x1.5)	1050 Nm (M90x1.5)
Nut (12)	15 Nm		25 Nm
Body nut (1.1)	10 Nm (M10)	30 Nm (M12)	90 Nm (M16)
Coupling nut (5.1)	80 Nm		

15.2 Spare parts

2	Plug stem with metal bellows seal	121	Hex nut
10	Coupling nut	122	Retaining washer
11	Hex nut	123	Washer
12	Retaining washer	130	Gasket
13	Washer	135	Nut
17	Plug	161	Seat
20	Body	162	Seat
22	Nameplate	201	Pipe
27	Flanged pipe	202	Stem
29	Grooved pin	203	Hex nut
34	Flange	206	Seal (PTFE)
40	Pipe	207	V-ring packing
41	Pipe	208	Washer
43	Pipe	209	Compression spring
44	Pipe	210	Washer
46	Seal (graphite)	211	Threaded bushing
51	Stud	213	Hex nut
52	Hex nut	214	Threaded pin
56	Label (mixing valve)	215	Nipple

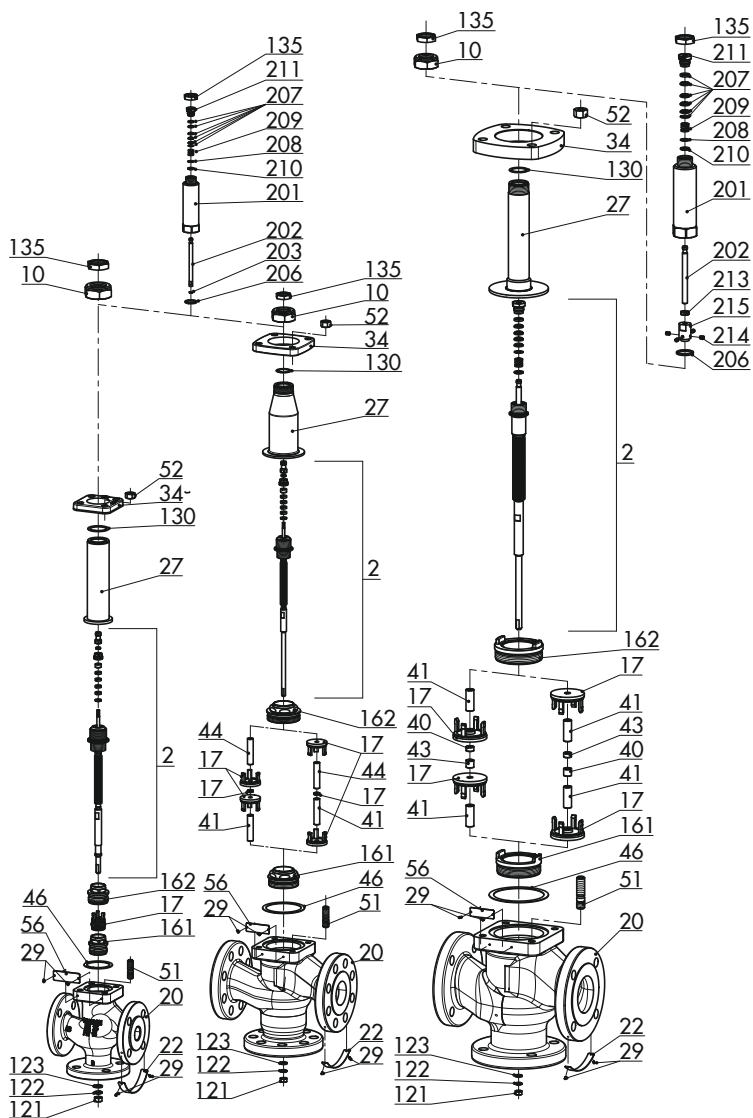

DN 15 to 25
Mixing or
diverting valve

DN 32 to 50
Mixing valve (left)
Diverting valve (right)

DN 80
Mixing valve (left)
Diverting valve (right)

15.3 After-sales service

Contact our after-sales service for support concerning service or repair work or when malfunctions or defects arise.

E-mail address

You can reach our after-sales service at aftersalesservice@samsongroup.com.

Addresses of SAMSON AG and its subsidiaries

The addresses of SAMSON AG, its subsidiaries, representatives and service facilities worldwide can be found on our website (www.samsongroup.com) or in all SAMSON product catalogs.

Required specifications

Please submit the following details:

- Order number and position number in the order
- Type, model number, valve size and valve version
- Pressure and temperature of the process medium
- Flow rate in m³/h
- Bench range (signal pressure range) (e.g. 1.4 to 2.3 bar with a pneumatic actuator)
- Is a strainer installed?
- Installation drawing

EB 8135/8136 EN



SAMSON AKTIENGESELLSCHAFT
Weismüllerstraße 3 · 60314 Frankfurt am Main, Germany
Phone: +49 69 4009-0 · Fax: +49 69 4009-1507
samson@samsongroup.com · www.samsongroup.com