

# Type 3372 Electropneumatic Actuator

SAMSON

Versions with 120 and 350 cm<sup>2</sup>  
and Type 3725 Positioner



*Globe valve with Type 3372 Electropneumatic Actuator  
Versions with 120 cm<sup>2</sup> and 350 cm<sup>2</sup> effective diaphragm areas*

## Mounting and Operating Instructions

**EB 8313-3 EN**

Edition July 2013

CE

## Definition of signal words



### **DANGER!**

*Hazardous situations which, if not avoided, will result in death or serious injury*



### **WARNING!**

*Hazardous situations which, if not avoided, could result in death or serious injury*



### **NOTICE**

*Property damage message or malfunction*



### **Note:**

*Additional information*



### **Tip:**

*Recommended action*

<b>1</b>	<b>General safety instructions</b> .....	<b>7</b>
<b>2</b>	<b>Design and principle of operation</b> .....	<b>8</b>
2.1	Versions .....	8
2.1.1	Type 3372 (120 cm <sup>2</sup> ) .....	8
2.1.2	Type 3372 (350 cm <sup>2</sup> ) .....	8
2.2	Signal pressure routing .....	12
2.2.1	Version with fail-safe action „actuator stem extends“ (FA) .....	12
2.2.2	Version with fail-safe action „actuator stem retracts“ (FE) .....	12
2.3	Fail-safe action .....	13
2.3.1	Version with fail-safe action “actuator stem extends” (FA) .....	13
2.3.2	Version with fail-safe action “actuator stem retracts” (FE) .....	13
2.4	Technical data .....	14
<b>3</b>	<b>Application</b> .....	<b>14</b>
3.1	Throttling service .....	15
3.2	On/off service .....	15
<b>4</b>	<b>Mounting on the valve</b> .....	<b>16</b>
4.1	Type 3372 (120 cm <sup>2</sup> ) .....	16
4.1.1	Mounting using a central nut .....	16
4.1.2	Mounting using rods .....	18
4.2	Type 3372 (350 cm <sup>2</sup> ) – mounting using rods .....	18
4.3	Changing the type of mounting .....	20
4.3.1	Conversion of mounting using a central nut to rods .....	20
4.3.2	Conversion of mounting using rods to a central nut .....	20
4.4	Attaching the Type 3725 Positioner .....	22
4.4.1	Actuator with fail-safe action „actuator stem extends“ (FA) .....	22
4.4.2	Actuator with fail-safe action „actuator stem retracts“ (FE) .....	22
4.5	Attaching the Type 4744-2 Limit Switch .....	24
<b>5</b>	<b>Operation</b> .....	<b>25</b>
5.1	Type 3372 (120 cm <sup>2</sup> ) with travel stop .....	25
5.1.1	Limiting the minimum travel .....	25
5.1.2	Limiting the maximum travel .....	26
5.2	Type 3372 (120 cm <sup>2</sup> ) with manual override .....	26
5.2.1	Actuator with fail-safe action „actuator stem extends“ (FA) .....	26
5.2.2	Actuator with fail-safe action „actuator stem retracts“ (FE) .....	26

<b>6</b>	<b>Maintenance of Type 3372 (120 cm<sup>2</sup>)</b> .....	<b>28</b>
6.1	Removing the actuator .....	28
6.1.1	Releasing the spring preloading .....	28
6.2	Removing the diaphragm plate assembly .....	28
6.3	Dismantling the diaphragm plate assembly .....	30
6.3.1	Version with fail-safe action „actuator stem extends“ (FA) .....	30
6.3.2	Version with fail-safe action „actuator stem retracts“ (FE) .....	30
6.4	Assembly based on the direction of action .....	30
6.4.1	Version with fail-safe action „actuator stem extends“ (FA) .....	30
6.4.2	Version with fail-safe action „actuator stem retracts“ (FE) .....	30
6.5	Replacing seals and plain bearings .....	30
6.5.1	Radial shaft seal, wiper ring and plain bearings .....	31
6.5.2	Version with travel stop .....	31
6.5.3	Version with manual override .....	32
6.6	Mounting the actuator .....	33
6.6.1	Version with fail-safe action „actuator stem extends“ (FA) .....	33
6.6.2	Version with fail-safe action „actuator stem retracts“ (FE) .....	33
6.6.3	Assembling the diaphragm cases .....	33
6.7	Mounting on the valve .....	34
<b>7</b>	<b>Maintenance of Type 3372 (350 cm<sup>2</sup>)</b> .....	<b>36</b>
7.1	Removing the actuator .....	36
7.1.1	Reducing the spring preloading .....	36
7.2	Removing the diaphragm plate assembly .....	36
7.3	Dismantling the diaphragm plate assembly .....	38
7.3.1	Version with fail-safe action „actuator stem extends“ (FA) .....	38
7.3.2	Version with fail-safe action „actuator stem retracts“ (FE) .....	38
7.4	Assembly based on the direction of action .....	38
7.4.1	Version with fail-safe action „actuator stem extends“ (FA) .....	38
7.4.2	Version with fail-safe action „actuator stem retracts“ (FE) .....	38
7.5	Replacing seals and plain bearing .....	39
7.5.1	Radial shaft seal, wiper ring and plain bearing .....	39
7.6	Mounting on the valve .....	39
7.7	Connections .....	39
<b>8</b>	<b>Reversing the direction of action (fail-safe action)</b> .....	<b>39</b>

9	Nameplate.....	40
10	Dimensions and weights .....	40
11	Customer inquiries .....	41



## 1 General safety instructions

- The actuator is to be mounted, started up or operated only by trained and experienced personnel familiar with the product. According to these mounting and operating instructions, trained personnel refers to individuals who are able to judge the work they are assigned to and recognize possible dangers due to their specialized training, their knowledge and experience as well as their knowledge of the applicable standards.
- Explosion-protected versions of this actuator are to be operated only by personnel who has undergone special training or instructions or who is authorized to work on explosion-protected devices in hazardous areas.
- Any hazards that could be caused in the valve by the process medium, the signal pressure or by moving parts are to be prevented by means of the appropriate measures.
- If inadmissible motions or forces are produced in the pneumatic actuator as a result of the supply pressure level, it must be restricted using a suitable supply pressure reducing station.
- Proper shipping and storage are assumed.

**Note:**

*The actuator with a CE marking fulfills the requirements of the Directive 94/9/EC and the Directive 2004/108/EC.*

*The Declaration of Conformity is available on request.*

---

## 2 Design and principle of operation

The Type 3372 Electropneumatic Actuator is mainly used for attachment to Series V2001 Valves:

- Type 3321 Globe Valve
- Type 3323 Three-way Valve
- Type 3531 Globe Valve for Heat Transfer Oil
- Type 3535 Three-way Valve for Heat Transfer Oil

The actuator mainly consists of two diaphragm cases (1 and 2) with a diaphragm (4) and internal springs (10). The actuator is connected to the valve bonnet by a rod-type yoke. The Type 3725 Electropneumatic Positioner is attached to the rod (33) with the largest diameter using a support element (61). This positioner converts the control signal received from a control system (4 to 20 mA reference variable) into a proportional pressure signal.

The signal pressure ( $p_{st}$ , S port) creates a force at the diaphragm surface which is opposed by the compression springs (10) in the actuator. The number of springs and their compression determine the bench range (signal pressure range). The travel is always proportional to the signal pressure.

The stem connector connects the actuator stem (7) to the plug stem of the mounted valve.

## 2.1 Versions

### 2.1.1 Type 3372 (120 cm<sup>2</sup>)

- Actuator with die-cast aluminum housing
- Standard use for attachment to Type 3321 and Type 3323 Valves in DN 15 to 50 as well as Type 3531 and Type 3535 Valves in DN 15 to 80 (corresponds to Form B in Table 1).

Optionally, the actuator can be fitted with a mechanically adjustable travel stop or a manual override.

### 2.1.2 Type 3372 (350 cm<sup>2</sup>)

- Actuator with sheet steel housing (see Fig. 1)
- Standard use for attachment to Type 3321 Valves in DN 65 to 100 as well as Type 3323 Valves in DN 65 to 100 for 15 or 30 mm travel (corresponds to Form C in Table 1).

This actuator version cannot be fitted with a manual override or travel stop.



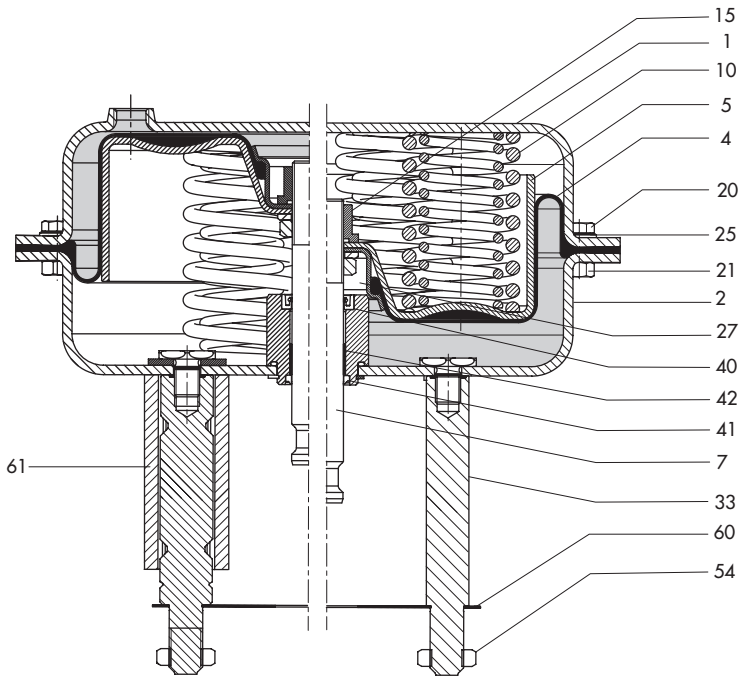

- |     |                    |    |                      |
|-----|--------------------|----|----------------------|
| 1/2 | Diaphragm case     | 27 | Compressor           |
| 4   | Diaphragm          | 33 | Rod                  |
| 5   | Diaphragm plate    | 40 | Radial shaft seal    |
| 7   | Actuator stem      | 41 | Wiper ring           |
| 10  | Compression spring | 42 | Plain bearing        |
| 15  | Collar nut         | 54 | Hexagon nut (for 33) |
| 20  | Hexagon bolt       | 60 | Plate                |
| 21  | Hexagon nut        | 61 | Support element      |
| 25  | Washer             |    |                      |

Fig. 1: Type 3372 Actuator (350 cm<sup>2</sup>)

**Table 1:** Attachment of Type 3372 Actuator to Series V2001 Valves

				120 cm <sup>2</sup>			
				Stem extends		Stem retracts	
				2.1 to 3.3	1.4 to 2.3	0.4 to 1.4	1.4 to 2.3
Type	DN	K <sub>V5</sub>	Travel	15 mm			
3321	15 to 50	0.25 to 35	15 mm	B	B	B	B
3321	65 to 100	40 to 100		C*	–	C*	–
3323	15 to 50	4 to 32		–	B	–	B
3323	65 to 80	60 to 80		–	–	–	–
3321	100	160	30 mm	–	–	–	–
3323	100	160		–	–	–	–
3531	15 to 80	1.6 to 80	15 mm	B	B	B	B
3535	15 to 80	4 to 80		B	B	B	B

\* See Fig. 7

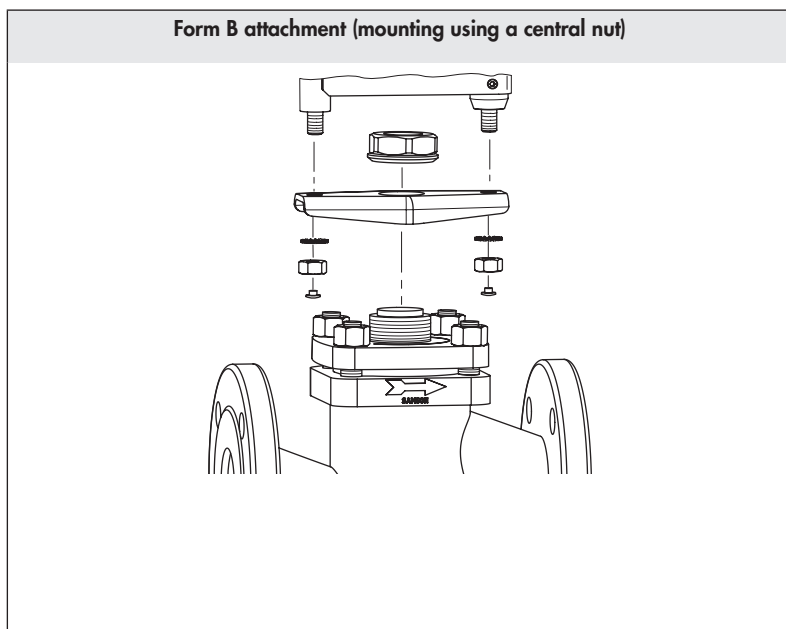

		350 cm <sup>2</sup>						
		Stem extends	Stem retracts	Stem extends	Stem retracts			
		2.1 to 2.7	1.5 to 2.1	2.2 to 3.8	1.5 to 2.7			
		15 mm		30 mm		K <sub>VS</sub>	DN	Type
		–	–	–	–	0.25 to 35	15 to 50	3321
		C	C	–	–	40 to 100	65 to 100	3321
		–	–	–	–	4 to 32	15 to 50	3323
		C	C	–	–	60 to 80	65 to 80	3323
		–	–	C	C	160	100	3321
		–	–	C	C	160	100	3323
		–	–	–	–	1.6 to 80	15 to 80	3531
		–	–	–	–	4 to 80	15 to 80	3535

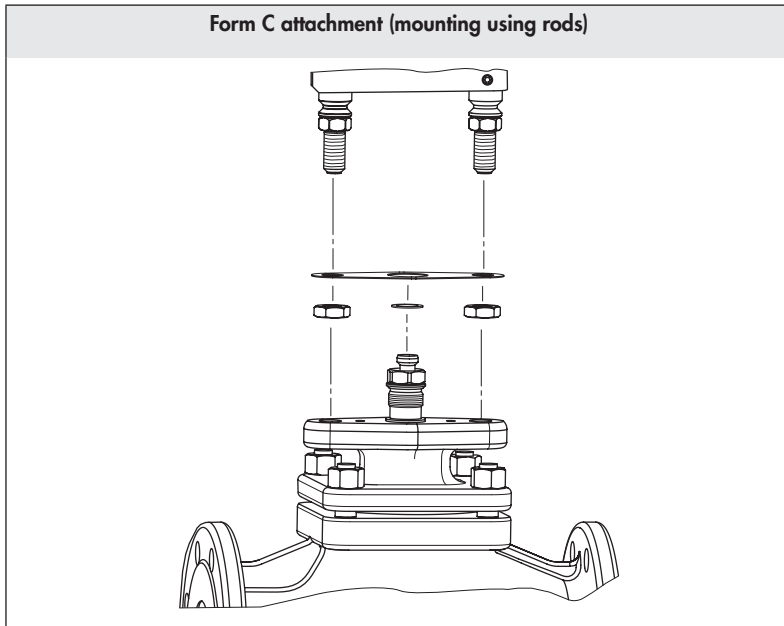

**Table 2:** Mounting on Type 3372 Actuator on HVAC valves

	Version	Type 3725 Positioner (direct attachment)	
	Actuator area	120 cm <sup>2</sup>	
	Travel	15 mm	30 mm
Type to Valve	Nominal size DN		
3214	65 to 100	Form B	-
3214	125 to 150	-	On request
3260	65 to 80	Form B	-
3260	100 to 150	-	On request

## 2.2 Signal pressure routing

The signal pressure of the Type 3725 Positioner (62) is routed through the corresponding port in the support element (61).

### 2.2.1 Version with fail-safe action „actuator stem extends“ (FA)

The signal pressure in the actuator version with fail-safe action „actuator stem extends“ is transmitted directly through the support element to the bottom diaphragm chamber. The actuator stem is moved upward opposing the spring force (see Fig. 2).

If an additional solenoid valve is used, a modified support element is used to route the signal pressure.

### 2.2.2 Version with fail-safe action „actuator stem retracts“ (FE)

The support element of the actuator version with fail-safe action „actuator stem retracts“ has a borehole at the side. The signal pressure is transmitted over an external pipe to the top diaphragm chamber. The actuator stem is moved downward opposing the spring force (see Fig. 3).

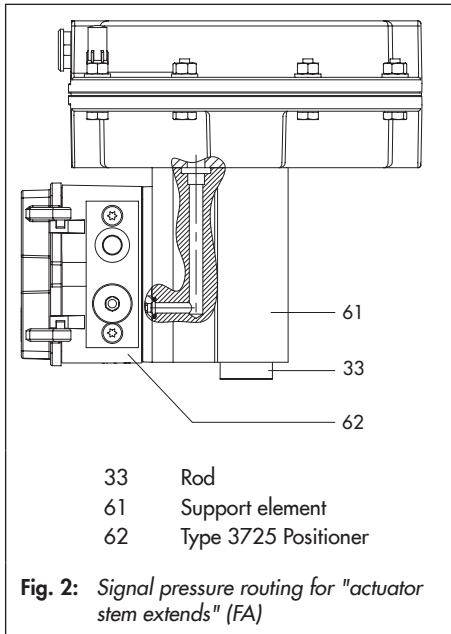

## 2.3 Fail-safe action

When the signal pressure fails, the fail-safe action of the actuator depends on whether the springs are installed in the top or bottom diaphragm chamber.

**Note**  
It is **not** possible to change the operating direction of Type 3372 Actuator by changing the location of the diaphragm plate.

### 2.3.1 Version with fail-safe action "actuator stem extends" (FA)

When the signal pressure is reduced or the air supply fails, the springs move the actuator stem downward and close the globe valve. The valve opens when the signal pressure is increased enough to overcome the force exerted by the springs.

### 2.3.2 Version with fail-safe action "actuator stem retracts" (FE)

When the signal pressure is reduced or the air supply fails, the springs move the actuator stem upward and open the globe valve. The valve closes when the signal pressure is increased enough to overcome the force exerted by the springs.

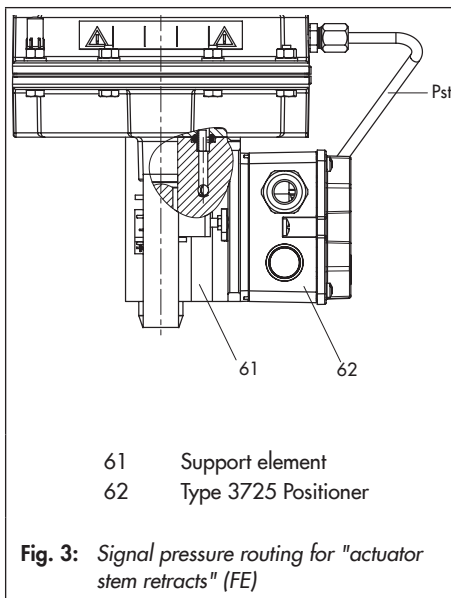

**Note**  
To prevent the actuator from being damaged, observe the restrictions for on/off service. See section 3.2.

## 2.4 Technical data

Type 3372 Actuator								
Diaphragm area	120 cm <sup>2</sup>				350 cm <sup>2</sup>			
Bench range in bar	0.4 to 1.4	1.4 to 2.3		2.1 to 3.3	1.5 to 2.1	2.1 to 2.7	1.5 to 2.7	2.2 to 3.8
Fail-safe action	Stem retracts	Stem retracts	Stem extends	Stem extends	Stem retracts	Stem extends	Stem retracts	Stem extends
Travel	15 mm						30 mm	
Supply pressure	Max. 6 bar · Observe the restrictions for on/off service							
Ambient temperature range	-35 to 90 °C <sup>1)</sup>				-35 to 90 °C <sup>1)</sup>			
Weight, approx.	3.3 kg				15 kg			
Material								
Actuator housing	Aluminum, powder-paint coated				1.0332			
Diaphragm	NBR				NBR			
Actuator stem	1.4305				1.4401/1.4404			
Electropneumatic positioner								
Type 3725	Refer to Data Sheet ► T 8394 and Mounting and Operating Instructions ► EB 8394							
Electric limit switch								
Type 4744-2	One electric limit contact · 15 mm travel range ► T 8367 and ► EB 8367						-	

<sup>1)</sup> **NOTICE** Observe temperature limits of the mounted valve accessories.

## 3 Application



### Note

To mount the actuator on the valve or to remove it from the valve, follow the instructions written in the mounting and operating instructions of the corresponding valve.

### 3.1 Throttling service

The Type 3372 Pneumatic Actuator is designed for a maximum supply pressure of 6 bar when used for throttling service.

### 3.2 On/off service

To prevent the actuator from being damaged, the supply pressure must not exceed the upper spring range value by more than 3 bar at the maximum when the actuator with fail-safe action „actuator stem retracts“ is used for on/off service.

**Table 3:** Example

Bench range	Fail-safe action	Max. supply pressure
0.2 to 1.0 bar	Actuator stem retracts	4 bar
0.4 to 2.0 bar		5 bar
0.6 to 3.0 bar		6 bar

Label actuators with reduced supply pressure correspondingly:

***Max. supply pressure limited to 2 bar***

For actuators with fail-safe action „actuator stem extends“ and with a travel stop, the supply pressure must not exceed the upper spring range value by more than 1.5 bar at the maximum.

### 4 Mounting on the valve

The valve and actuator are delivered separately and must be assembled on site. If the positioner is already mounted on the actuator (on the support element), it must be removed before the actuator can be mounted onto the valve.

#### 4.1 Type 3372 (120 cm<sup>2</sup>)

The actuator is normally mounted onto the valve bonnet (34) using its crossbeam (59) and a central nut (35).

However, the actuator with its two rods can also be mounted onto valves with the corresponding valve bonnet without the crossbeam. See section 4.1.2.

##### 4.1.1 Mounting using a central nut

Form B, see Table 1 on page 10

###### Fig. 4

This type of mounting applies to Type 3321 and Type 3323 Valves in DN 15 to 50 as well as Type 3531 and Type 3535 Valves in DN 15 to 80. It involves mounting the actuator onto the valve bonnet (34) using a central nut (35).



#### NOTICE

Do not undo the hex nuts (54) that hold the crossbeam (59) in place on the rod-type yoke.

- Push the plug together with the plug stem into the seat.
- Place the actuator with the crossbeam (59) onto the thread of the valve bonnet (34), making sure that the central nut (35, SW 36) is placed over the plug stem, and fasten it to the valve bonnet. This causes the actuator stem to be pressed down approximately 1 to 2 mm against the force of the springs. Tightening torque of the nut = 150 Nm.



#### WARNING!

For actuators with fail-safe action „actuator stem retracts“ (FE), air must be applied to the top diaphragm chamber until the actuator stem touches the plug stem.

**Risk of crushing!** Do not touch the yoke.

The stem connector clamps can then be mounted between the actuator stem and plug stem.

- Mount the stem connector clamps, while aligning the follower clamp for the follower pin of the positioner parallel to the support element.

- Unscrew the central nut (35) from the valve bonnet (34).



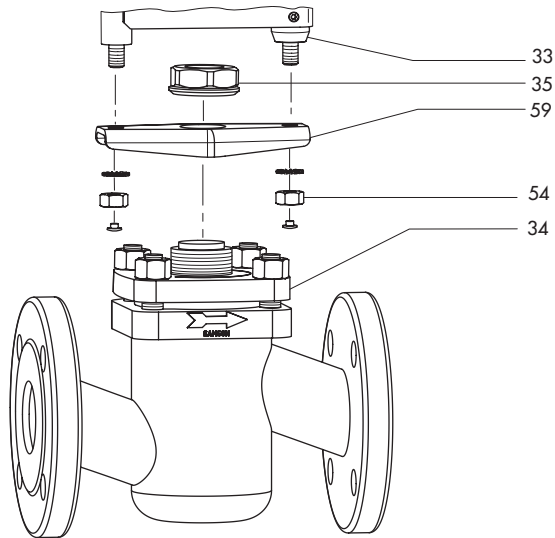

- 33 Rod
- 34 Valve bonnet
- 35 Central nut
- 54 Hex nut (for 33)
- 59 Crossbeam

Fig. 4: Mounting using central nut – Type 3372-120 cm<sup>2</sup>

## 4.1.2 Mounting using rods

See Table 1 on page 10 for Form C

The Type 3372 Actuator (120 cm<sup>2</sup>) is suitable for mounting on Type 3321 Valves in DN 65 to 100 with 15 mm travel.

The rod ends are fitted with adapter bushings (33.1) to provide a threaded attachment. Additionally, a plate (60) ensures the correct distance between the rods.

- Place the rods (33) in the corresponding holes on the valve bonnet (34).
- Hold the hexagonal part of the rods stationary using an open-end wrench (width across flats 22) and fasten each rod with a hex nut. During which, the actuator stem is pressed down approx. 1 to 2 mm.
- Place the stem connector clamp with travel linkage behind the actuator stem and fasten the other clamp onto it using two screws.  
At the same time, align the follower clamp for the follower pin of the positioner parallel to the support element (61).



### **WARNING!**

*For actuators with fail-safe action „actuator stem retracts“ (FE), air must be applied to the top diaphragm chamber until the actuator stem touches the plug stem.*

**Risk of crushing!** Do not touch the yoke.

*The stem connector clamps can then be mounted.*

## 4.2 Type 3372 (350 cm<sup>2</sup>) – mounting using rods

See Table 1 on page 10 for Form C

### **Fig. 5**

The actuator with 350 cm<sup>2</sup> diaphragm area is designed for Types 3321 and 3323 Valves in DN 65 to 100 with 15 or 30 mm travel.

- Before mounting, unscrew the hex nuts (54) from the rods. The plate (60) remains attached to the rods.
- Place the actuators with the rod ends onto the valve bonnet (34). Tighten the two hex nuts (54) alternately, while holding the rods stationary at the hexagonal part with an open-end wrench (width across flats 22) to prevent the rods from turning in the bottom diaphragm case.



### **WARNING!**

*For actuators with fail-safe action „actuator stem retracts“ (FE), air must be applied to the actuator until the actuator stem touches the plug stem.*

**Risk of crushing!** Do not touch the yoke.

- Mount the stem connector clamps between the actuator stem and the plug stem, while aligning the follower clamp for the follower pin of the positioner parallel to the support element.

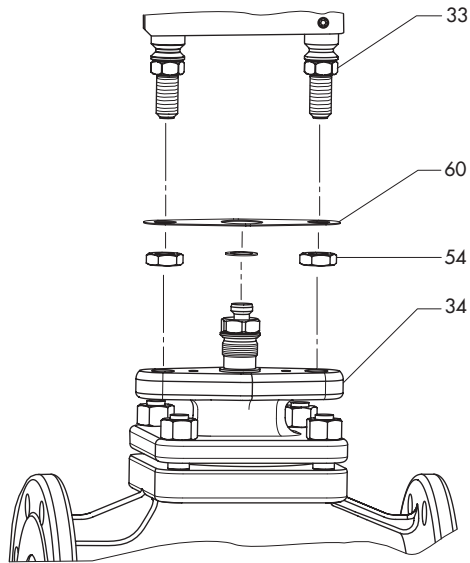

- 33 Rod
- 34 Valve bonnet
- 54 Hex nut (for 33)
- 60 Plate

Fig. 5: Mounting on rods - Type 3372 (350 cm<sup>2</sup>)

## 4.3 Changing the type of mounting

A Type 3372 Actuator (120 cm<sup>2</sup>) which has already been mounted using a central nut can also be mounted later to a valve bonnet suitable for mounting using rods. This requires a plate (60) and two adapter bushings (33.1) with hexagonal section to adapt it to the diameter of the rods (33).

The conversion in the other direction is also possible. This requires a crossbeam (59) and two nuts (54).

### 4.3.1 Conversion of mounting using a central nut to rods

See Table 1 on page 10 for conversion from Form B to Form C

Fig. 6 and Fig. 7

- Undo the two screws on the stem connector and remove it from the actuator stem and plug stem.
- Undo the central nut (35) and lift the actuator off the valve bonnet (34).
- To undo the two hex nuts (54), the rods (33) must be held stationary using an open-end wrench (SW 22). Remove the crossbeam (59).
- Position the plate (60) and screw the two adapter bushings (33.1) onto the thread of the rods (33). This adapts the diameter of the rods to the holes in the valve bonnet (34).

- Place the rods (33) on the valve bonnet (34) and tighten both hex nuts (54) alternately.
- Mount the stem connector between the actuator stem and plug stem, ensuring the travel linkage runs parallel to the support element.

### 4.3.2 Conversion of mounting using rods to a central nut

See Table 1 on page 10 for conversion from Form C to Form B

Fig. 6 and Fig. 7

- Undo the two screws on the stem connector and remove it from the actuator stem and plug stem.
- Unscrew the hex nuts (54) from the adapter bushings (33.1) and lift the actuator of the valve bonnet (34).
- Unscrew the adapter bushings (33.1) with hexagonal part from the rods (33) and remove the plate (60).
- Place the crossbeam (59) on the rods (33) with the bent sides facing away from the actuator housing. Fasten with hex nuts (54).
- Place the actuator on the valve bonnet (34) and fasten with central nut (35).
- Mount the stem connector between the actuator stem and plug stem, ensuring the travel linkage runs parallel to the support element.

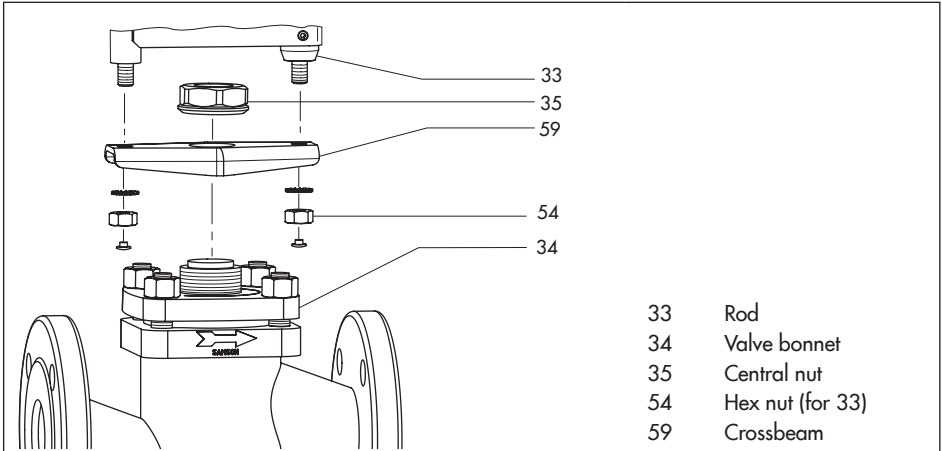

- 33 Rod
- 34 Valve bonnet
- 35 Central nut
- 54 Hex nut (for 33)
- 59 Crossbeam

**Fig. 6:** *Mounting using central nut – Type 3372 (120 cm<sup>2</sup>)*

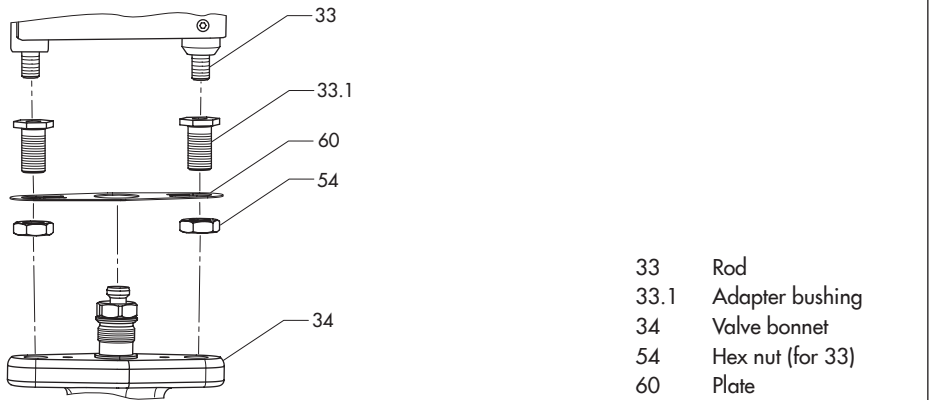

- 33 Rod
- 33.1 Adapter bushing
- 34 Valve bonnet
- 54 Hex nut (for 33)
- 60 Plate

**Fig. 7:** *Mounting on rods - Type 3372-120 cm<sup>2</sup>*

## 4.4 Attaching the Type 3725 Positioner

### Fig. 8

If the positioner (62) is to be used with an actuator with fail-safe action „actuator stem extends“ (FA), the signal pressure output must be open. See associated Mounting and Operating Instructions ► EB 8394 for Type 3725 Positioner.

To use it with an actuator with fail-safe action „actuator stem retracts“ (FE), the signal pressure output of the positioner must be sealed. To proceed, unscrew the screw plug from park position and screw it into the signal pressure output, as described in ► EB 8394.

- Hold the positioner on the support element (61) as shown, while at the same time, lifting the lever (62.2) to allow the follower pin (62.1) slide into the oblong hole of the follower clamp.
- Fasten the positioner to the support element (61) using the two captive screws.

### 4.4.1 Actuator with fail-safe action „actuator stem extends“ (FA)

The signal pressure is routed from the positioner (62) through a hole in the support element (61) to the bottom diaphragm chamber. The vent plug is located on the top diaphragm case.

### 4.4.2 Actuator with fail-safe action „actuator stem retracts“ (FE)

The signal pressure is transmitted from the positioner over an external pipe to the top diaphragm chamber.

The bottom diaphragm chamber is vented through a side venting plug over corresponding hole in the support element specially designed for this purpose.

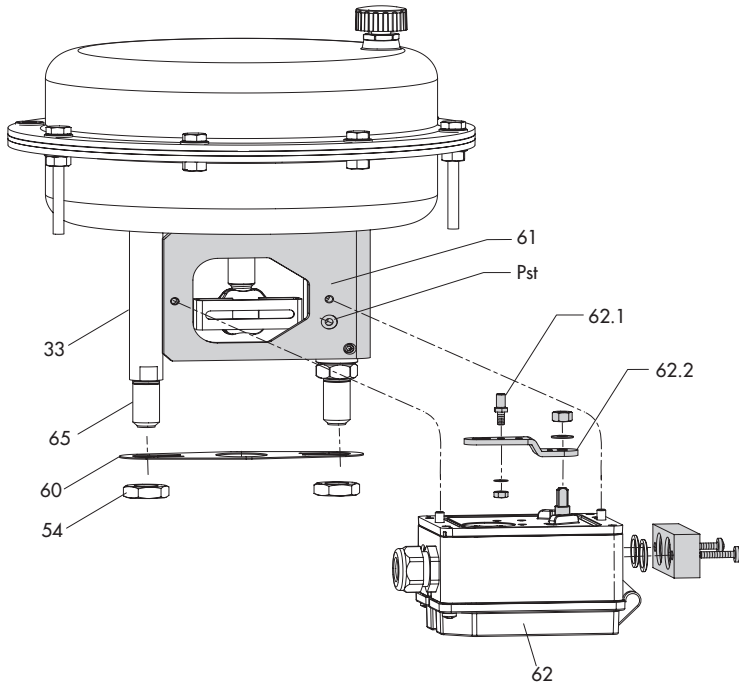

- 61 Support element
- 62 Type 3725 Positioner
- 62.1 Follower pin
- 62.2 Lever

Fig. 8: Attaching the Type 3725 Positioner

## 4.5 Attaching the Type 4744-2 Limit Switch

Fig. 9

The optional limit switch is mounted using a clamping plate to the free rod (33) opposite the positioner.

- Remove the stem connector between the actuator stem and plug stem. Replace the front clamp with the clamp that has a welded-on bracket on it from the accessories.
- Move the valve to the switching point at which the contact is to be activated.
- Position the clamping plate on the rod (33) at the point where the lever rests on the bracket of the stem connector.

- Align clamping plate and secure it in place.
- Move the actuator towards and past the required switching point, while adjusting the exact switching point at the adjusting screw.

Refer to Mounting and Operating Instructions ► EB 8367 for more details on the limit switch.



Fig. 9: Type 4744-2 Limit Switch attached to Type 3323/3372 Control Valve



## 5 Operation

These Mounting and Operating Instructions describe the mechanical operation of the actuator. The operation of the Type 3725 Positioner is described in the Mounting and Operating Instructions ► EB 8394. These instructions describe start-up and the settings and how to operate the positioner.

**!** **NOTICE**  
Only apply the signal pressure to the diaphragm chamber of the actuator which does not contain any springs.

The applicable bench range which the actuator can move through is written on the nameplate.

It is essential that the vent plug lets air through it to allow the actuator to work properly.

### 5.1 Type 3372 (120 cm<sup>2</sup>) with travel stop

#### Fig. 10

The actuator can optionally be fitted with an adjustable travel stop to limit the minimum and maximum travel. These stops can be combined.

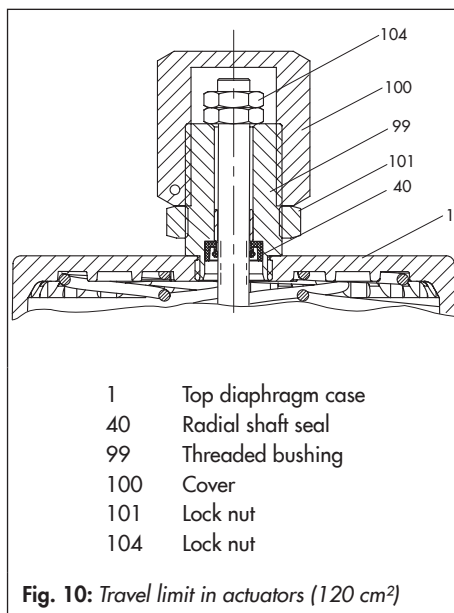

#### 5.1.1 Limiting the minimum travel

- Undo lock nut (101) and remove cover (100).
- Undo the lock nut (104).
- Move actuator to the position of minimum travel.
- Thread the bottom nut (104) on as far as it will go and lock this position with the top nut (104).

If the minimum travel is not to be limited, thread the nuts (104) until they reach the end of the actuator stem and lock them in position.

- Reattach the cover (100) and tighten the lock nut (101).

### 5.1.2 Limiting the maximum travel

- Undo lock nut (101) and remove cover (100).
- Move actuator to the position of maximum travel.
- Screw back on the cover (100) until it reaches the stop point and retighten the lock nut (101).

## 5.2 Type 3372 (120 cm<sup>2</sup>) with manual override

Fig. 11

The actuator stem can be moved by the optional manual override over a shaft (72). The actuator is moved opposing the force of its springs.

### 5.2.1 Actuator with fail-safe action „actuator stem extends“ (FA)

In actuators with fail-safe action „actuator stem extends“ (FA), a globe valve is opened by the manual override.

- Turn the handwheel counterclockwise. The pin (75) moves upward in the oblong hole of the sleeve (76) until the shaft (72) is raised. The actuator stem retracts into the actuator.

### 5.2.2 Actuator with fail-safe action „actuator stem retracts“ (FE)

In actuators with fail-safe action „actuator stem retracts“ (FE), a globe valve is closed by the manual override.

- Turn the handwheel clockwise. The pin (75) moves downward in the oblong hole of the sleeve (76) until the shaft (72) also moves downward. The actuator stem extends out of the actuator.

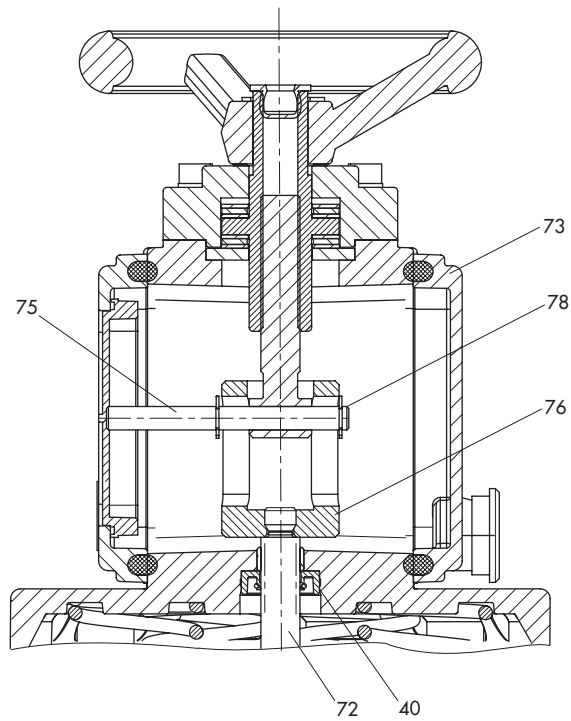

- 40 Radial shaft seal
- 72 Shaft
- 73 Cover
- 75 Pin
- 76 Sleeve
- 78 Washer

Fig. 11: Manual override for Type 3372 (120 cm<sup>2</sup>)

## 6 Maintenance of Type 3372 (120 cm<sup>2</sup>)

Fig. 12

If the actuator does function properly, it may be necessary to replace parts subject to wear



**Note:**

We recommend the following tools and resources for maintenance:

- Lubricant: order no. 8152-0043
- Thread-locking fluid: order no. 8121-3010
- Mandrel or hook to remove seals
- Piece of pipe to mount seals and plain bearings
- Torque wrench

Before performing any maintenance work, the actuator must be removed from the valve.

- ➔ Detach the electrical and pneumatic connections from the positioner. Remove the external piping from the positioner to the top of the actuator with fail-safe action „actuator stem retracts“ (FE).

### 6.1 Removing the actuator

The actuator must be dismantled to replace, for example, damaged seals or plain bearings. A defective diaphragm additionally requires the dismantling of the diaphragm plate assembly. The following instructions apply to the standard version.

If the actuator is fitted with an optional travel limit, the components for the travel limit must be first removed before following the instructions described in the next section. The same

applies for an actuator fitted with manual override.

Mark both diaphragm cases (1 and 2) to ensure that the pneumatic connections are mounted correctly later on reassembling the actuator.

#### 6.1.1 Releasing the spring preloading

- ➔ Unscrew and remove the hex nuts (21) on the short bolts (20) on the diaphragm casing.
- ➔ Unthread the hex nuts on the long bolts a few turns, alternating between them to gradually release the spring preloading.

### 6.2 Removing the diaphragm plate assembly

- ➔ Lift off the top diaphragm case (1).
- ➔ Remove all springs (10) in the actuator with fail-safe action „actuator stem extends“ (FA).
- ➔ Take the diaphragm plate (5) together with the diaphragm (4) and actuator stem (7) out of the bottom diaphragm case (2).
- ➔ Remove the springs (10) now accessible in the actuator with fail-safe action „actuator stem retracts“ (FE).
- ➔ Lift and take the diaphragm plate assembly out of the bottom diaphragm case.

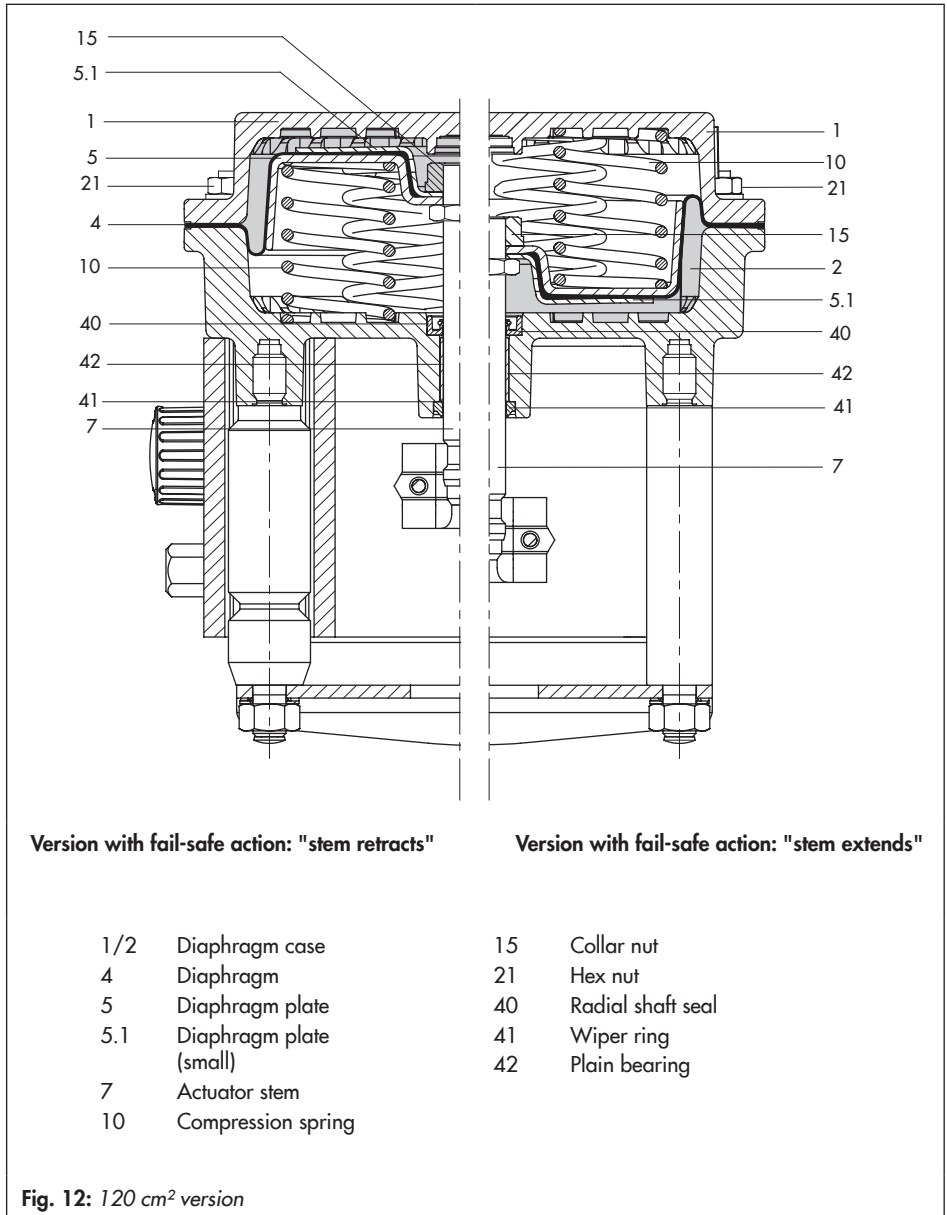

Fig. 12: 120 cm<sup>2</sup> version

## 6.3 Dismantling the diaphragm plate assembly

The diaphragm plate assembly only needs to be dismantled if the diaphragm is damaged and needs replacing as a result.

→ Clamp the actuator stem (7, Fig. 12) in a suitable appliance.

Remove the components in the sequence described:

### 6.3.1 Version with fail-safe action „actuator stem extends“ (FA)

→ Unscrew the self-sealing collar nut (15, Fig. 12).

→ Lift off large diaphragm plate (5), diaphragm (4) and small diaphragm plate.

### 6.3.2 Version with fail-safe action „actuator stem retracts“ (FE)

→ Unscrew the self-sealing collar nut (15, Fig. 12).

→ Lift off small diaphragm plate (4), diaphragm (5) and large diaphragm plate.

## 6.4 Assembly based on the direction of action

Before assembling, check each part, especially the diaphragm (4, Fig. 12), for damage. Damaged parts must be replaced with new ones.

Assemble in the reverse order as described for dismantling. The parts are to be assembled as shown in the associated drawing.

### 6.4.1 Version with fail-safe action „actuator stem extends“ (FA)

→ Place the small diaphragm plate (5.1, Fig. 12), diaphragm (4) and the diaphragm plate (5) on the actuator stem (7) in the given sequence.

→ Thread the (self-sealing) collar nut on the actuator stem and tighten with 30 Nm.

### 6.4.2 Version with fail-safe action „actuator stem retracts“ (FE)

→ Place the diaphragm plate (5, Fig. 12), diaphragm (4) and small diaphragm plate (5.1) on the actuator stem (7) in the given sequence.

→ Thread the (self-sealing) collar nut on the actuator stem and tighten with 30 Nm.

## 6.5 Replacing seals and plain bearings

The radial shaft seal (40, Fig. 12) and the wiper ring (41) and the plain bearing (42), if necessary, must be renewed due to wear or during repair work.

### 6.5.1 Radial shaft seal, wiper ring and plain bearings

- Use a suitable mandrel or hook to remove the radial shaft seal (40).
- Apply lubricant (8152-0043) to the new radial shaft seal and carefully install it, making sure the seal lip does not get damaged.
- If necessary, remove the wiper ring (41) and plain bearing (42) with a suitable mandrel or piece of pipe. Renew these components, if necessary.
- Apply lubricant (8152-0043) to parts (40), (41) and (42).
- Reassemble actuator as described in section 6.4.

### 6.5.2 Version with travel stop

Fig. 13

The Type 3271 Actuator (120 cm<sup>2</sup>) can optionally fitted with a travel stop. Additionally, a radial shaft seal and a dry bearing are located in the top diaphragm case (1).

- Undo lock nut (101) and remove cover (100).
- Undo both nuts (104).

After undoing the hex nuts, carefully lift the top diaphragm case (1) off the actuator stem.

- Use a suitable mandrel or hook to remove the top radial shaft seal (40) and/or dry bearing.
- Use a suitable piece of pipe to install a new dry bearing.

- Install the new radial shaft seal, making sure the seal lip does not get damaged.
- Before assembling, check each part, especially the diaphragm, for damage. Damaged parts must be replaced with new ones.

Assemble the actuator in the reverse order.

- Carefully push the diaphragm case (1) together with the radial shaft seal (40) onto the actuator stem.
- Align the case (1) and fasten with washers and nuts (21).
- Mount nuts (104), adjust, if necessary and lock in place.
- Reattach the cover (100), adjust and lock in position with the lock nut (101).

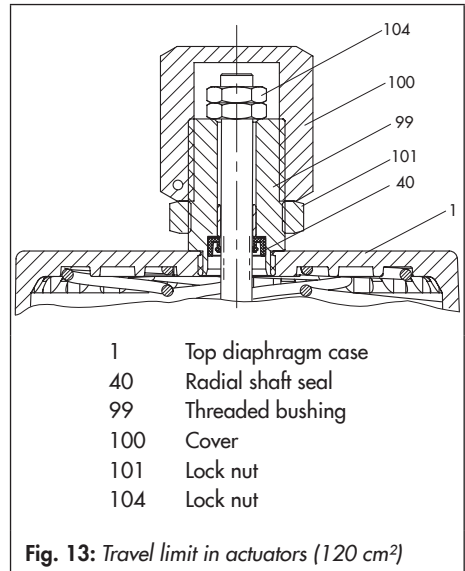

### 6.5.3 Version with manual override

**Fig. 14**

The Type 3372 Actuator (120 cm<sup>2</sup>) can optionally fitted with a manual override. Additionally, a radial shaft seal and a dry bearing are located in the top diaphragm case (1).

- Undo the two washers (78) and remove pin (75).
- Hold sleeve (76) and turn the handwheel until the sleeve reaches the top stop.
- Remove the top diaphragm case.

- Use a suitable mandrel or hook to remove the radial shaft seal (40) and/or dry bearing.
- Use a suitable piece of pipe to install a new dry bearing.
- Install the new radial shaft seal, making sure the seal lip does not get damaged.

Before assembling, check each part, especially the diaphragm, for damage. Damaged parts must be replaced with new ones.

Reassemble the actuator as described in section 6.4. The parts are to be assembled as shown in the associated drawing.

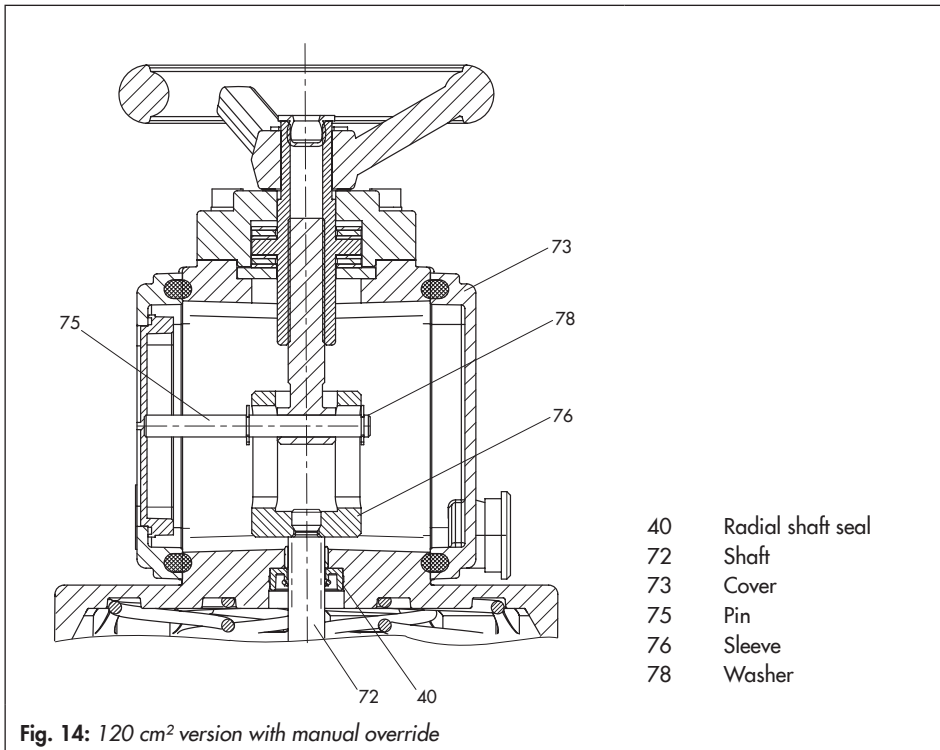



## 6.6 Mounting the actuator

Fig. 15

### 6.6.1 Version with fail-safe action „actuator stem extends“ (FA)

- Clamp the bottom diaphragm case (2) into a suitable appliance.
- Carefully insert the ready-assembled diaphragm plate assembly through the radial shaft seal (40) into the plain bearing (42) of the diaphragm case (2). Take care not to damage the radial shaft seal (40).
- Align the diaphragm (4) to the holes in the diaphragm case.
- Place the springs (10) on the diaphragm plate, centering them in the intended recesses.
- Place on the top diaphragm case (1) and align its holes.

#### Version with travel stop or manual override

- Carefully place the top diaphragm case (1) with travel stop/manual override onto the actuator stem extension. Take care not to damage the radial shaft seal (40).

Proceed as described in section 6.6.3.

### 6.6.2 Version with fail-safe action „actuator stem retracts“ (FE)

- Clamp the top diaphragm case (1) into a suitable appliance. This ensures that the position of the springs (10) remains unchanged during assembly.
- Place the ready-assembled diaphragm plate assembly together with diaphragm plate in the top diaphragm case (1).

#### Version with travel stop or manual override

- Carefully insert the actuator stem extension through the radial shaft seal of the diaphragm case. Take care not to damage the radial shaft seal (40).
- Place the springs (10) on the diaphragm plate, centering them in the intended recesses.
- Carefully push the bottom diaphragm case (2) together with the radial shaft seal and plain bearing over the actuator stem. Take care not to damage the radial shaft seal (40) and wiper ring (41).

Proceed as described in section 6.6.3

### 6.6.3 Assembling the diaphragm cases

- Align the diaphragm and diaphragm case so that their holes are located over each other. If you marked the diaphragm cases before dismantling the actuator, you can re-establish where the pneumatic connections were located.

- If the springs are to be preloaded, insert the long bolts (20) through the holes used previously on the top diaphragm case. Mount long hex nuts (21) each with one washer until they rest on the diaphragm case.
- Hold the bolt heads stationary and tighten the hex nuts in an even pattern until the diaphragm is clamped between both diaphragm cases.
- Insert the short bolts (20) with nuts (21) and washers.
- Tighten all nuts with 6.3 Nm in a criss-cross pattern.
- Mount the actuator onto the valve following the instructions in the mounting and operating instructions of the valve.

### 6.7 Mounting on the valve

Proceed as described in section 4.

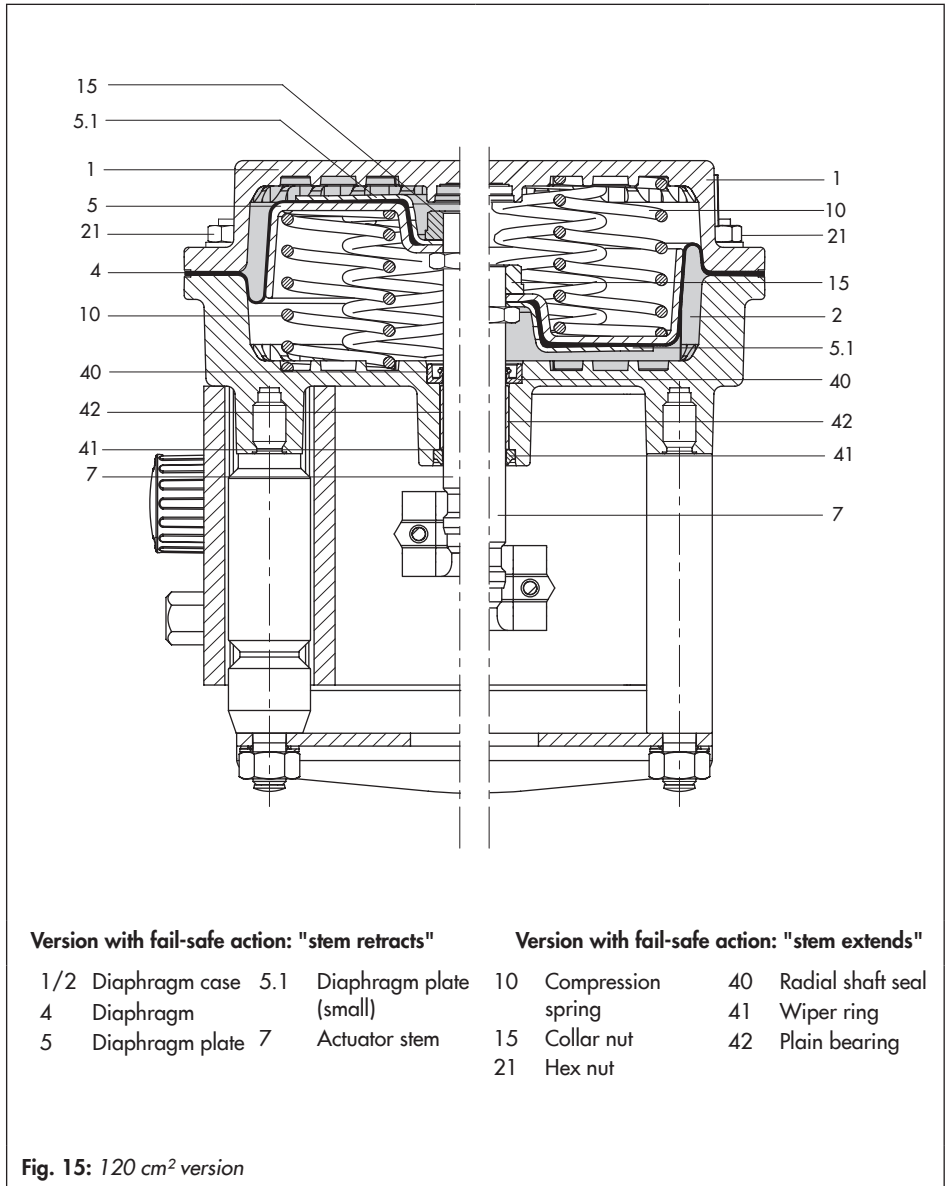

Fig. 15: 120 cm<sup>2</sup> version

## 7 Maintenance of Type 3372 (350 cm<sup>2</sup>)

Fig. 16

Parts subject to wear may need to be replaced if the actuator does not work properly.



### Note

We recommend the following tools and resources for maintenance:

- Socket wrench (width across flats 27) for 350 cm<sup>2</sup> version
- Lubricant: Order no. 8152-0043
- Thread-locking fluid: Order no. 8121-3010
- Mandrel or hook to remove seals
- Piece of pipe to mount seals and plain bearings
- Torque wrench

Before performing any maintenance work, the actuator must be removed from the valve.

- Detach the electrical and pneumatic connections from the positioner. Remove the external piping from the positioner to the top of the actuator with fail-safe action „actuator stem retracts“ (FE).

## 7.1 Removing the actuator

The actuator must be dismantled to replace, for example, damaged seals or plain bearings. A defective diaphragm additionally requires the dismantling of the diaphragm plate assembly.

### 7.1.1 Reducing the spring preloading

- Unscrew and remove the hex nuts on the short bolts on the diaphragm casing.
- Unthread the hex nuts on the long bolts a few turns, alternating between them to gradually release the spring preloading.

### 7.2 Removing the diaphragm plate assembly

- Lift off the top diaphragm case (1).
- Remove all springs (10) in the actuator with fail-safe action „actuator stem extends“ (FA).
- Take the diaphragm plate (5) together with the diaphragm (4) and actuator stem (7) out of the bottom diaphragm case.
- Remove the springs (10) now accessible in the actuator with fail-safe action „actuator stem retracts“ (FE).
- Lift and take the diaphragm plate assembly out of the bottom diaphragm case.

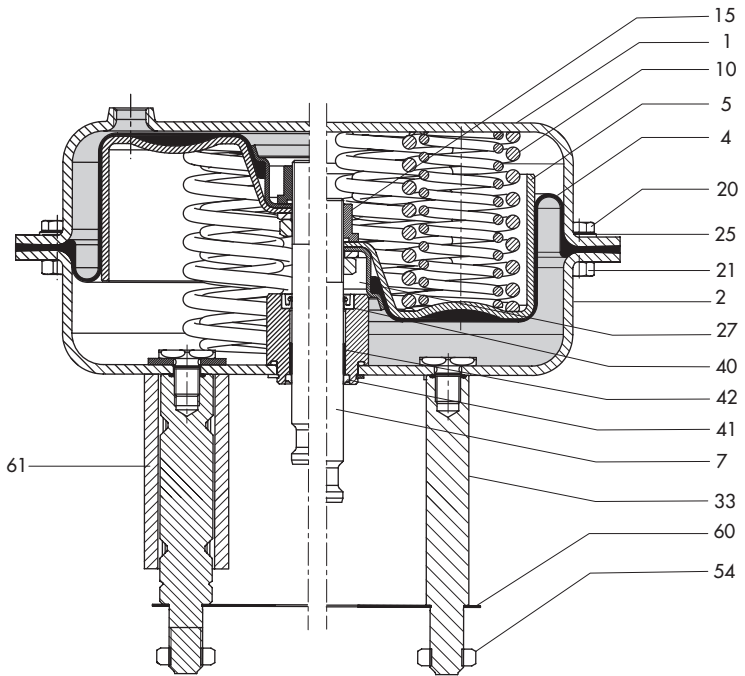

Version with fail-safe action: "stem retracts"

Version with fail-safe action: "stem extends"

- |     |                    |    |                   |
|-----|--------------------|----|-------------------|
| 1/2 | Diaphragm case     | 25 | Washer            |
| 4   | Diaphragm          | 27 | Compressor        |
| 5   | Diaphragm plate    | 33 | Rod               |
| 7   | Actuator stem      | 40 | Radial shaft seal |
| 10  | Compression spring | 41 | Wiper ring        |
| 15  | Collar nut         | 42 | Plain bearing     |
| 20  | Hexagon screw      | 54 | Hex nut (for 33)  |
| 21  | Hex nut            | 60 | Plate             |
|     |                    | 61 | Support element   |

Fig. 16: 350 cm<sup>2</sup> version

## 7.3 Dismantling the diaphragm plate assembly

The diaphragm plate assembly only needs to be dismantled if the diaphragm is damaged and needs replacing as a result.

- Use a suitable appliance, e.g. a long socket wrench (width across flats 27) to clamp the actuator stem (7).

Remove the components in the sequence described:

### 7.3.1 Version with fail-safe action „actuator stem extends“ (FA)

- Unscrew the (self-sealing) collar nut (15).
- Remove the large diaphragm plate (5) , diaphragm (4) and compressor (27) in the given sequence.

### 7.3.2 Version with fail-safe action „actuator stem retracts“ (FE)

- Unscrew the (self-sealing) collar nut (15).
- Remove the compressor (27), diaphragm (4) and large diaphragm plate (5) in the given sequence.

## 7.4 Assembly based on the direction of action

Before assembling, check each part, especially the diaphragm, for damage. Damaged parts must be replaced with new ones.

Assemble in the reverse order as described for dismantling. The parts are to be assembled as shown in the associated drawing for fail-safe action „actuator stem extends“ or „actuator stem retracts“.

### 7.4.1 Version with fail-safe action „actuator stem extends“ (FA)

- Insert the compressor (27).
- Pull the diaphragm (4) onto the diaphragm plate (5) and place them on the actuator stem.
- Screw on new collar nut (15). Tighten with 100 Nm.

### 7.4.2 Version with fail-safe action „actuator stem retracts“ (FE)

- Place the diaphragm plate (5) together on the actuator stem.
- Mount the compressor (27).
- Screw on new collar nut (15). Tighten with 100 Nm.

## 7.5 Replacing seals and plain bearing

The radial shaft seal (40) and the wiper ring (41) and the plain bearing (42), if necessary, must be renewed due to wear or during repair work.

### 7.5.1 Radial shaft seal, wiper ring and plain bearing

- Use a suitable mandrel or hook to remove the radial shaft seal (40).
- Carefully install the new radial shaft seal, making sure the seal lip does not get damaged.
- If necessary, remove the wiper ring (41) and plain bearing (42) with a suitable mandrel or piece of pipe. Renew these components, if necessary.
- Apply lubricant (8152-0043) to parts (40), (41) and (42).
- Reassemble actuator.

## 7.6 Mounting on the valve

Proceed as described in section 4.

## 7.7 Connections

The actuator is fitted with M20x1.5 black plastic cable glands and a pneumatic connecting plate G ¼ as standard. If other connections are required, use the accessories listed in the mounting and operating instructions of the positioner.

- Type 3725 Positioner ► EB 8394
- Type 3730 Positioner ► EB 8384-2 (for example)
- Type 3731 Positioner ► EB 8387-3 (for example)

The reducing station for supply air can be directly attached when combined with a Type 3730 Positioner. All other reducing stations must be attached with an external hook-up.

## 8 Reversing the direction of action (fail-safe action)

The reversal direction of action, i.e. fail-safe action, of Type 3372 (120 cm<sup>2</sup>) and Type 3372 (350 cm<sup>2</sup>) Actuators is not intended.

## 9 Nameplate

The plastic nameplates for the actuators are stuck on the diaphragm casing. They include all details required to identify the actuator:

- Manufacturer and type number (SAMSON 3372)
- Configuration ID (Var.-ID) as bar code and plain text
- Serial number
- Country of origin
- Diaphragm area in cm<sup>2</sup> (120 cm<sup>2</sup>/350 cm<sup>2</sup>)
- Symbol for manual override
- Symbol indicating fail-safe action:
- Bench range in bar or psi
- Operating travel in mm
- Permissible supply pressure  $p_{max}$  in bar or psi

## 10 Dimensions and weights

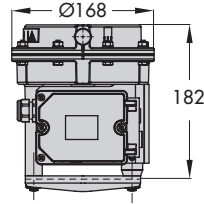

Actuator stem extends/retracts  
 Type 3372 (120 cm<sup>2</sup>) with Type 3725, 7 kg

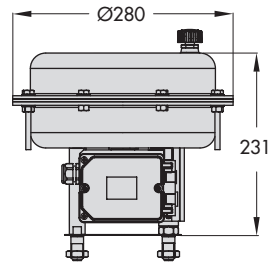

Actuator stem extends/retracts  
 Type 3372 (350 cm<sup>2</sup>) with Type 3725, 16 kg



## 11 Customer inquiries

Please submit the following details written on the nameplate:

- Type designation and serial number
- Effective area in  $\text{cm}^2$
- Bench range (spring range) in bar
- Actuator version and fail-safe action
- Your e-mail address

**Please send your inquiries to:**  
**service@samson.de**







SAMSON AG · MESS- UND REGELTECHNIK  
Weismüllerstraße 3 · 60314 Frankfurt am Main, Germany  
Phone: +49 69 4009-0 · Fax: +49 69 4009-1507  
samson@samson.de · www.samson.de

**EB 8313-3 EN**

2016-02-04 · English