

T 8052 EN

Series 250 · Type 3251-1 and Type 3251-7 Pneumatic Control Valves

Type 3251 Globe Valve

ANSI version



Application

Control valve for process engineering applications with high industrial requirements

Valve size	NPS ½ to 20
Pressure rating	Class 150 to 2500
Temperatures	-325 to +1022 °F (-196 to +550 °C)

Special features

Type 3251 Globe Valve operated with

- Type 3271 Pneumatic Actuator (Type 3251-1 Control Valve)
- Type 3277 Pneumatic Actuator (Type 3251-7 Control Valve) for integral positioner attachment

Valve body made of

- Cast steel
- Cast stainless steel, high-temperature cast steel or cast cold-resisting steel
- Special materials

Low-noise valve plug

- Metal seal
- Soft seal up to Class 300
- High-performance metal seal
- Balanced to handle high differential pressures

Optional with RFID tags with unique identification according to DIN SPEC 91406.

The control valves with their modular design can be equipped with various accessories:

Positioners, limit switches, solenoid valves and other valve accessories according to IEC 60534-6-1 ¹⁾ and NAMUR recommendation (see Information Sheet ▶ T 8350).

Versions

Standard version with PTFE packing for temperatures from 14 to 428 °F (-10 to +220 °C) or with adjustable high-temperature packing from 14 to 662 °F (-10 to +350 °C), valve size NPS ½ to 20, pressure rating Class 150 to 2500 (see Table 1)

- **Type 3251-1** (Fig. 1) · Type 3251 Valve and Type 3271 Actuator with 350 to 2800 cm² actuator area (see Data Sheets ▶ T 8310-1, ▶ T 8310-2 and ▶ T 8310-3)

¹⁾ Accessories required. See associated actuator documentation.



Fig. 1: Type 3251-1 Pneumatic Control Valve with Type 3271 Pneumatic Actuator

- **Type 3251-7** · Type 3251 Valve and Type 3277 Actuator with 350 to 750v2 cm² actuator area for integral positioner attachment (see Data Sheet ▶ T 8310-1)

Further versions

- **Welding ends or welding-neck ends** according to ANSI B16.25
- **Flow divider or AC-1/AC-3 Trim** for noise reduction · See Data Sheets ▶ T 8081, ▶ T 8082 and ▶ T 8083
- **Valve plug with pressure balancing** · See Table 3
- **Perforated plug** · See ▶ T 8086
- **Insulating section or bellows seal** · See Technical data
- **Heating jacket** · Details on request
- **Additional handwheel** · See Data Sheet ▶ T 8310-1

- **DIN version** · DN 15 to 500, PN 16 to 400 · See Data Sheet ▶ T 8051
- **Type 3251 Valve with Type 3273 Hand-operated Actuator** · For valves with max. 30 mm rated travel and side-mounted handwheel for travel > 30 mm · See Data Sheet ▶ T 8312
- **Type 3251-2 Electric Control Valve** · Details on request

Principle of operation

The medium flows through the valve in the direction indicated by the arrow. The valve plug determines the cross-sectional area of flow. The version with bellows seal (Fig. 4) is fitted with a test connection to monitor the stainless steel bellows.

The valves can be equipped with a flow divider (▶ T 8081) for noise reduction.

Pressure balancing must be used when high pressures or differential pressures act on the plug (Fig. 3).

Fail-safe action

Depending on how the springs are arranged in the pneumatic actuator (see Data Sheets ▶ T 8310-1, ▶ T 8310-2 and ▶ T 8310-3), the valve has two different fail-safe positions that become effective when the supply air fails.

- **Actuator stem extends (fail-close)**
The valve closes when the supply air fails.
- **Actuator stem retracts (fail-open)**
The valve opens when the supply air fails.

Differential pressures

The permissible differential pressures can be found in the Information Sheet ▶ T 8000-4.

Fig. 2 to Fig. 4 show configuration examples.

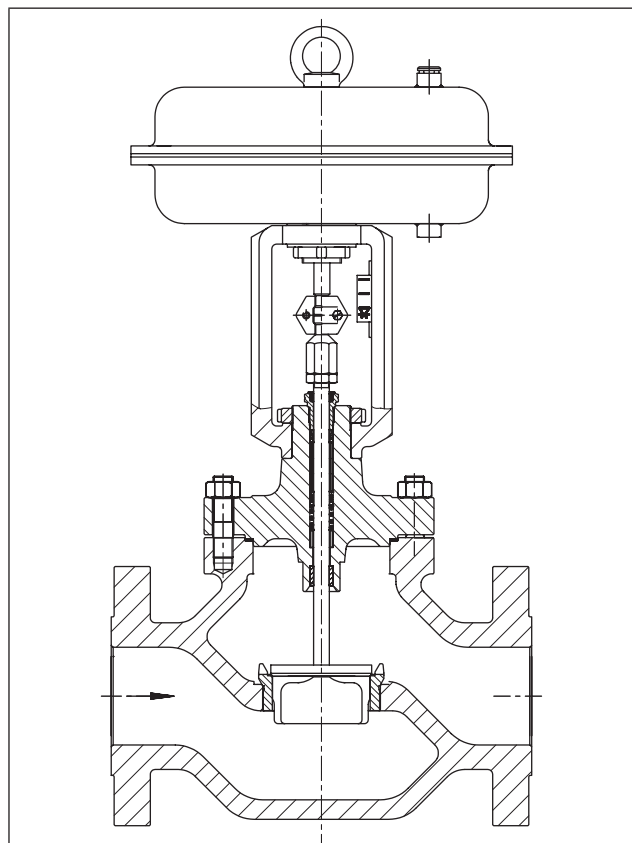

Fig. 2: Type 3251-1 Control Valve with Type 3271 Pneumatic Actuator

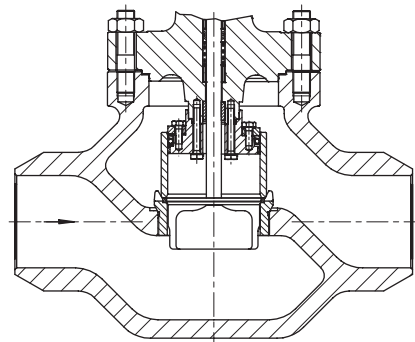

Fig. 3: Type 3251 Valve with welding ends and balanced plug

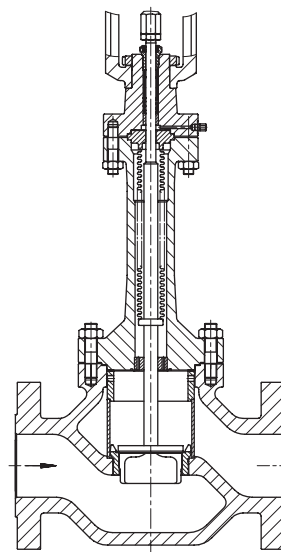



Fig. 4: Type 3251 Valve with flow divider ST 1 and additional bellows seal with test connection

Table 1: Technical data for Type 3251

Material	Cast steel A216 WCC	Cast steel A217 WC6	Cast stainless steel A351 CF8M	
Valve size and pressure rating	NPS ½ to 12 in Class 150 to 2500 NPS 14 in Class 150 to 600 NPS 16 to 20 in Class 150 to 1500			
Type of connection	Flanges	All ANSI versions		
	Welding ends	According to ANSI B16.25		
Seat-plug seal	Metal seal · Soft seal · High-performance metal seal			
Characteristic	Equal percentage · Linear · On/off (▶ T 8000-3)			
Rangeability	50:1			
RFID tag (optional)	Application range according to the technical specifications and the explosion protection certificates. Documents ▶ www.samsongroup.com > Service & Support > Electronic nameplate			
Conformity				
Temperature ranges in °F (°C) · Permissible operating pressures acc. to pressure-temperature diagrams (see Information Sheet ▶ T 8000-2)				
Body without insulating section	14 to 428 (-10 to +220 °C) · Up to 662 (350 °C) with high-temperature packing			
Body with	Insulating section or bellows seal	-20 to +800 (-29 to +425)	-20 to +932 (-29 to +500)	-325 to +1022 (-196 to +550) ²⁾
Valve plug ¹⁾	Standard	Metal seal	-325 to +1022 (-196 to +550) ²⁾	
		Soft seal	-325 to +428 (-196 to +220) ²⁾	
		Balanced with PTFE ring	-58 to +428 (-50 to +220) ³⁾	
		Balanced with graphite ring	428 to 932 (220 to 500) ⁴⁾	
RFID tag (optional)	Max. permissible temperature at the RFID tag: 185 °F (85 °C)			
Leakage class according to ANSI/FCI 70-2				
Valve plug	Standard	Metal seal	Standard: IV · High-performance metal seal: V	
		Soft seal	VI	
		Balanced, metal seal	With PTFE (standard): IV · High-performance metal seal: V With graphite ring: IV	

1) Only in combination with suitable body material

2) Note: The temperature limits are not directly converted temperatures.

3) Lower temperatures on request

4) Higher temperatures on request

Table 2: Materials

Standard version Body ¹⁾	Cast steel A216 WCC	Cast steel A217 WC6	Cast stainless steel A351 CF8M
Valve bonnet	A216 WCC/A105	A217 WC6/A 182 F12 Cl.2	A351 CF8M/A182 F316
Seat and plug ²⁾	Metal seal	410-2/1.4008	
Seal ring for	Soft seal	PTFE with 15 % glass fiber	
	Pressure balancing	PTFE with carbon · Graphite	
Guide bushings	1.4112		2.4610
Packing ³⁾	V-ring packing: PTFE with carbon, spring: 302 or high-temperature packing		
Body gasket	Graphite seal on metal core		
Insulating section	A216 WCC/A105	A217 WC6/A 182 F12 Cl.2	A351 CF8M/A182 F316
Metal bellows seal ⁵⁾			
Intermediate piece	A216 WCC/A105	A217 WC6/A 182 F12 Cl.2	A351 CF8M/A182 F316
Metal bellows	1.4571 ⁴⁾		
Heating jacket	A240 316L		

1) Other materials (e.g. for high-temperatures or low temperatures) as well as special materials for applications with seawater, such as 1.4538, duplex 1.4470, nickel-based alloy 9.4610, see pressure-temperature diagrams in Information Sheet ▶ T 8000-2

2) Seats and metal-seated plug also with Stellite® facing or plug made of solid Stellite® available (up to max. K_{V5} 630)

3) Other packings on request (▶ T 8000-1)

4) Other bellows materials on request

5) Bellows with both NPS >8 and Class >600 on request

Table 3: C_V and K_{VS} coefficients · Versions highlighted in gray also available with balanced plug

Terms for control valve sizing according to IEC 60534, Parts 2-1 and 2-2: $F_L = 0.95$, $X_T = 0.75$

Table 3.1: Overview with flow divider ST 1 (C_V-1 , $K_{VS}-1$), ST 2 (C_V-2 , $K_{VS}-2$) or ST 3 (C_V-3 , $K_{VS}-3$)

C_V	0.12 · 0.2 0.3 · 0.5	0.75	1.2	2	3	5	7.5	12	20	30	47	75	120	190	290	420	735	1150	1730	2300	2900	4200	
K_{VS}	0.1 · 0.16 0.25 · 0.4	0.63	1.0	1.6	2.5	4	6.3	10	16	25	40	63	100	160	250	360	630	1000	1500	2000	2500	3600	
C_V-1	-			1.7	2.6	4.2	7	10.5	17	26	42	67	105	170	265	375	650	1040	1560	2080	2600	3700	
$K_{VS}-1$	-			1.45	2.2	3.6	5.7	9	14.5	22	36	57	90	144	225	320	560	900	1350	1800	2250	3200	
C_V-2	-			-			3.7	6.0	9.5	15	23	37	60	95	145	235	335	580	950	1400	1860	2300	-
$K_{VS}-2$	-			-			3.2	5.0	8	13	20	32	50	80	125	200	290	500	800	1200	1600	2000	-
C_V-3	-			-			3.5	5.6	9	14	23	35	55	90	140	220	315	560	880	1280	1730	2200	-
$K_{VS}-3$	-			-			3	4.8	7.5	12	20	30	47	75	120	190	270	480	750	1100	1500	1900	-
Seat \varnothing [in]	0.24			0.47			0.945			1.22	1.5	1.97	2.48	3.15	3.94	4.92	5.91	7.87	9.84	11.81	13.78	15.75	19.69
Seat \varnothing [mm]	6			12			24			31	38	50	63	80	100	125	150	200	250	300	350	400	500
Rated travel [in]	0.59									1.18					2.36				4.72				
Rated travel [mm]	15									30					60				120				

Table 3.2: Versions without flow divider · Class 150 to 2500

C_V	0.12 · 0.2 0.3 · 0.5	0.75	1.2	2	3	5	7.5	12	20	30	47	75	120	190	290	420	735	1150	1730	2300	2900	4200
K_{VS}	0.1 · 0.16 0.25 · 0.4	0.63	1.0	1.6	2.5	4	6.3	10	16	25	40	63	100	160	250	360	630	1000	1500	2000	2500	3600
NPS	DN																					
1/2	15	•	•	•	•	•	• ¹⁾															
1	25	•	•	•	•	•	•	• ¹⁾														
1 1/2	40	•	•	•	•	•	•	•	• ¹⁾													
2	50					•	•	•	•	•	• ¹⁾											
3	80					•	•	•	•	•	•	• ¹⁾										
4	100								•	•	•	• ¹⁾										
6	150									•	•	•	• ¹⁾									
8	200										•	•	•	• ²⁾	•	• ¹⁾						
10	250											•	•	• ²⁾	•	•	• ¹⁾					
12	300												•	• ³⁾	•	•	•	• ¹⁾				
14	-														•	•	•	•	• ⁴⁾			
16	400														•	•	•	•	•	•	• ¹⁾	
20	500															•	•	•	•	•	•	• ¹⁾
				C_V	4.2	-	10.5	-	26	42	-	105	170	-	375	650	1040	1560	-	2600	3700	
				K_{VS}	3.6	-	9	-	22	36	-	90	144	-	320	560	900	1350	-	2250	3200	

¹⁾ Reduced C_V/K_{VS} coefficients with Class 900 to 2500:

²⁾ Pressure balancing only for \geq Class 600
³⁾ Pressure balancing only for Class 600/900
⁴⁾ For Class 150 to 600 only

Table 3.3: Versions with flow divider ST 1 · Class 150 to 900¹⁾

C_V-1	-			1.7	2.6	4.2	7	10.5	17	26	42	67	105	170	265	375	650	1040	1560	2080	2600	3700
$K_{VS}-1$	-			1.45	2.2	3.6	5.7	9	14.5	22	36	57	90	144	225	320	560	900	1350	1800	2250	3200
NPS	DN																					
1/2	15			•	•	•																
1	25			•	•	•	•	•														
1 1/2	40				•	•	•	•	•	•												
2	50					•	•	•	•	•	•											
3	80						•	•	•	•	•	•	•									
4	100								•	•	•	•	•									
6	150									•	•	•	•	•								
8	200										•	•	•	• ²⁾	•	•						
10	250											•	•	• ²⁾	•	•	•					
12	300												•	• ³⁾	•	•	•	•				
14	-														•	•	•	•				
16	400														•	•	•	•	•	•	•	•
20	500															•	•	•	•	•	•	•

¹⁾ Class 1500 to 2500 with flow divider ST 1 and pressure balancing on request
²⁾ Pressure balancing only for \geq Class 600
³⁾ Pressure balancing only for Class 600/900

Table 3.1: Overview with flow divider ST 1 (C_V-1, K_{VS}-1), ST 2 (C_V-2, K_{VS}-2) or ST 3 (C_V-3, K_{VS}-3)

C _V	0.12 · 0.2 0.3 · 0.5	0.75	1.2	2	3	5	7.5	12	20	30	47	75	120	190	290	420	735	1150	1730	2300	2900	4200	
K _{VS}	0.1 · 0.16 0.25 · 0.4	0.63	1.0	1.6	2.5	4	6.3	10	16	25	40	63	100	160	250	360	630	1000	1500	2000	2500	3600	
C _V -1	-			1.7	2.6	4.2	7	10.5	17	26	42	67	105	170	265	375	650	1040	1560	2080	2600	3700	
K _{VS} -1				1.45	2.2	3.6	5.7	9	14.5	22	36	57	90	144	225	320	560	900	1350	1800	2250	3200	
C _V -2	-						3.7	6.0	9.5	15	23	37	60	95	145	235	335	580	950	1400	1860	2300	-
K _{VS} -2							3.2	5.0	8	13	20	32	50	80	125	200	290	500	800	1200	1600	2000	-
C _V -3	-						3.5	5.6	9	14	23	35	55	90	140	220	315	560	880	1280	1730	2200	-
K _{VS} -3							3	4.8	7.5	12	20	30	47	75	120	190	270	480	750	1100	1500	1900	-
Seat Ø [in]	0.24			0.47			0.945			1.22	1.5	1.97	2.48	3.15	3.94	4.92	5.91	7.87	9.84	11.81	13.78	15.75	19.69
Seat Ø [mm]	6			12			24			31	38	50	63	80	100	125	150	200	250	300	350	400	500
Rated travel [in]	0.59									1.18					2.36				4.72				
Rated travel [mm]	15									30					60				120				

Table 3.4: Versions with flow divider ST 2 · Class 150 to 900¹⁾

C _V -2	-			3.7	6.0	9.5	15	23	37	60	95	145	235	335	580	950	1400	1860	2300	-			
K _{VS} -2				3.2	5.0	8	13	20	32	50	80	125	200	290	500	800	1200	1600	2000	-			
NPS	DN																						
2	50																						
3	80																						
4	100																						
6	150																						
8	200																						
10	250																						
12	300																						
14	-																						
16	400																						
20	500																						

¹⁾ Class 1500 to 2500 with flow divider ST 2 and pressure balancing on request

²⁾ Pressure balancing only for ≥ Class 600

³⁾ Pressure balancing only for Class 600/900

Table 3.5: Versions with flow divider ST 3 · Class 150 to 900¹⁾

C _V -3	-			3.5	5.6	9	14	23	35	55	90	140	220	315	560	880	1280	1730	2200	-			
K _{VS} -3				3.0	4.8	7.5	12	20	30	47	75	120	190	270	480	750	1100	1500	1900	-			
NPS	DN																						
2	50																						
3	80																						
4	100																						
6	150																						
8	200																						
10	250																						
12	300																						
14	-																						
16	400																						
20	500																						

¹⁾ Class 1500 to 2500 with flow divider ST 3 and pressure balancing on request

²⁾ Version not possible with bellows seal

³⁾ Only up to Class 300

⁴⁾ Pressure balancing only for ≥ Class 600

⁵⁾ Pressure balancing only for Class 600/900

Table 4: Dimensions for Type 3251-1 and Type 3251-7 Pneumatic Control Valves in standard version

Table 4.1: Type 3251 Valve · Face-to-face dimensions according to ANSI/ISA-75.08.01 for Class 600 and lower and according to ASME B16.10 for Class 900 and higher

Valve	NPS	DN	½	1	1½	2	3	4	6	8	10	12	14	16	20	
			15	25	40	50	80	100	150	200	250	300	-	400	500	
Length L (flanges RF and welding ends)	Class 150	in	7.25	7.25	8.75	10.00	11.75	13.88	17.75	21.38	26.50	29.00	35.00	40.00	On req.	
		mm	184	184	222	254	298	352	451	543	673	737	889	1016		
	Class 300	in	7.50	7.75	9.25	10.50	12.50	14.50	18.62	22.38	27.88	30.50	36.50	41.62	On req.	
		mm	190	197	235	267	318	368	473	568	708	775	927	1057		
	Class 600	in	8.00	8.25	9.88	11.25	13.25	15.50	20.00	24.00	29.62	32.25	38.25	43.62	On req.	
		mm	203	210	251	286	337	394	508	610	752	819	972	1108		
	Class 900	in	8.50	10.00	12.00	14.50	15.00	18.00	24.00	29.00	33.00	38.00	-	On request		
		mm	216	254	305	368	381	457	610	737	838	965	-	On request		
	Class 1500	in	8.50	10.00	12.00	14.50	18.50	21.61	27.75	32.75	39.00	44.50	-	On request		
		mm	216	254	305	368	470	549	705	832	991	1130	-	On request		
Class 2500	in	10.38	12.12	15.12	17.75	22.75	26.50	36.00	40.25	On request		-				
	mm	264	308	384	451	578	673	914	1022	On request		-				
Height H4	Class 150 to 600	in	5.98	5.98	6.46	8.54	8.74	9.53	12.36	15.24	17.40 ¹⁾	25.79	25.20	25.20	On req.	
		mm	152	152	164	217	222	242	314	387	442 ¹⁾	655	640	640		
	Class 900	in	7.32	7.32	7.68	9.88	8.74	9.53	12.36	15.24	20.43 ²⁾	23.90	-	On request		
		mm	186	186	195	251	222	242	314	387	519 ²⁾	607	-	On request		
	Class 1500 to 2500	in	7.32	7.32	7.68	9.88	11.34	13.7	18.35	22.44	On request		-	Class 1500 On request		
		mm	186	186	195	251	288	348	466	570	On request		-	Class 1500 On request		
H8 for actuator	350 cm ²	in	9.45	9.45	9.45	9.45	9.45	9.45	-							
		mm	240	240	240	240	240	240	-							
	355v2 cm ²	in	9.45	9.45	9.45	9.45	9.45	9.45	16.46	-						
		mm	240	240	240	240	240	240	418	-						
	700 cm ²	in	9.45	9.45	9.45	9.45	9.45	9.45	16.46	16.46	16.46	-				
		mm	240	240	240	240	240	240	418	418	418	-				
	750v2 cm ²	in	9.45	9.45	9.45	9.45	9.45	9.45	16.46	16.46	16.46	-				
		mm	240	240	240	240	240	240	418	418	418	-				
	1000 cm ²	in	-				11.61	11.61	11.61	16.46	16.46	On request				
		mm	-				295	295	295	418	418	On request				
	1400- 60 cm ²	in	-				11.61	11.61	11.61	16.46	16.46	On request				
		mm	-				295	295	295	418	418	On request				
	1400- 120 cm ²	in	-				18.90	18.90	18.90	19.80	19.80	19.80	25.59	25.59	25.59	25.59
		mm	-				480	480	480	503	503	503 ³⁾	650	650	650	650
2800 cm ²	in	-				18.90	18.90	18.90	19.80	19.80	19.80	25.59	25.59	25.59	25.59	
	mm	-				480	480	480	503	503	503 ³⁾	650	650	650	650	
2x 2800 cm ²	in	-				18.90	18.90	18.90	19.80	19.80	19.80	25.59	25.59	25.59	25.59	
	mm	-				480	480	480	503	503	503 ³⁾	650	650	650	650	
H2 (DN 100/ NPS 4 and larger with foot)	Class 150	in	1.97	2.36	3.05	3.54	3.94	6.3	8.66	9.84	12.21	14.57	15.16	16.34	On req.	
		mm	50	60	80	90	100	160	220	250	310	370	385	415		
	Class 300 to 600	in	2.36	2.76	3.54	3.94	4.72	7.09	9.25	10.63	11.82	15.35	On request			
		mm	60	70	90	100	120	180	235	270	300	390	On request			
	Class 900	in	2.76	3.05	3.94	4.33	4.72	7.09	9.25	On request			-	On request		
		mm	70	80	100	110	120	180	235	On request			-	On request		
	Class 1500	in	2.76	3.05	3.94	4.33	5.51	8.66	11.22	On request			-	On request		
		mm	70	80	100	110	140	220	285	On request			-	On request		
	Class 2500	in	2.95	3.54	4.33	4.72	6.3	9.33	12.6	On request			-	On request		
		mm	75	90	110	120	160	237	320	On request			-	On request		

¹⁾ NPS 10, Class 150 to 300: 442 mm or 17.40"

²⁾ NPS 10, Class 600 to 900: 519 mm or 20.43"

³⁾ H8 = 650 mm with 250 mm seat bore

Dimensional drawings

Type 3271 Pneumatic Actuator

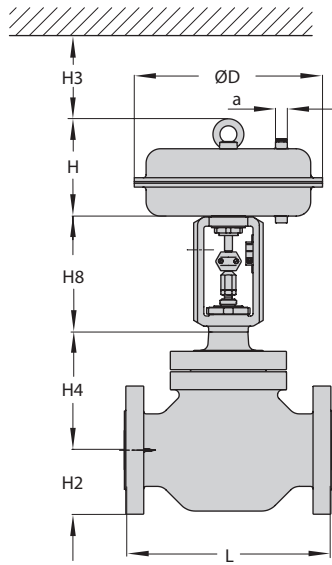

Type 3251-1
Up to NPS 3 without foot

Type 3271 Pneumatic Actuator

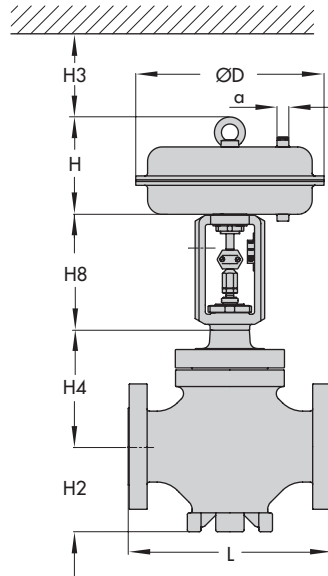

Type 3251-1
NPS 4 and larger

Type 3277 Pneumatic Actuator

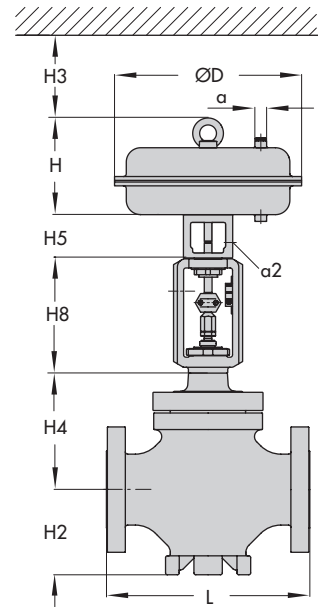

Type 3251-7

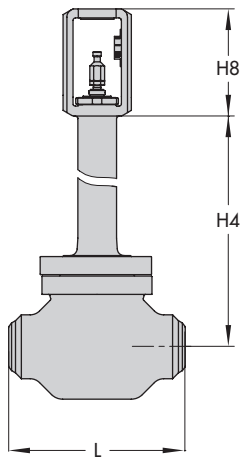

Type 3251 with bellows seal or insulating section

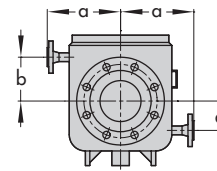
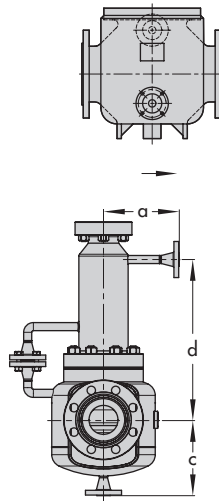

Type 3251 with heating jacket
Dimensions on request

Table 4.2: Type 3271 and Type 3277 Pneumatic Actuators

Actuator area	cm ²	350	355v2	700	750v2	1000	1400-60	1400-120	2800	2 x 2800	
Diaphragm ØD	in	11.02	11.02	15.35	15.51	18.19	20.87	21.02	30.32	30.32	
	mm	280	280	390	394	462	530	534	770	770	
H ¹⁾	in	3.23	4.76	7.83	9.29	15.87	13.27	23.54	28.07	47.76	
	mm	82	121	199	236	403	337	598	713	1213	
H3 ²⁾	in	4.33	4.33	7.48	7.48	24.02	24.02	25.59	25.59	25.59	
	mm	110	110	190	190	610	610	650	650	650	
H5	Type 3277 in	3.98	3.98	3.98	3.98	-	-	-	-	-	
	Type 3277 mm	101	101	101	101	-	-	-	-	-	
Thread	Type 3271	M30x1.5				M60x1.5		M100x2			
	Type 3277	M30x1.5				-	-	-	-	-	
α	Type 3271	G 3/8 (3/8 NPT)	G 3/8 (3/8 NPT)	G 3/8 (3/8 NPT)	G 3/8 (3/8 NPT)	G 3/4 (3/4 NPT)	G 3/4 (3/4 NPT)	G 1 (1 NPT)	G 1 (1 NPT)	G 1 (1 NPT)	
α2	Type 3277	G 3/8	G 3/8	G 3/8	G 3/8	-	-	-	-	-	

- 1) Height including lifting eyelet or female thread and eyebolt according to DIN 580. Height of the swivel hoist may differ. Actuators up to 355v2 cm² without lifting eyelet or female thread
 2) Minimum clearance required to remove the actuator

Table 5: Weights for Type 3251-1 and Type 3251-7 in standard version

Table 5.1: Type 3251 Valve

Valve	NPS	1/2	1	1 1/2	2	3	4	6	8	10	12	14	16	20	
		DN	15	25	40	50	80	100	150	200	250	300	-	400	500
Valve without actuator	Class 150	lbs	26	31	42	66	110	152	342	948	1892	2028	2965	3197	3638
		kg	12	14	19	30	50	69	155	430	858	920	1345	1450	1650
	Class 300	lbs	33	35	57	95	170	247	694	948	1892	2028	3010	3197	3638
		kg	15	16	26	43	77	112	315	430	858	920	1365	1450	1650
	Class 600	lbs	33	35	57	95	170	247	694	1096	1609	2535	On request		
		kg	15	16	26	43	77	112	315	497	730	1150	On request		
	Class 900	lbs	33	35	57	95	170	247	694	1157	2844	3263	-	5732	On req.
		kg	15	16	26	43	77	112	315	525	1290	1480	-	2600	On req.
	Class 1500	lbs	On req.	75	126	159	348	496	1235	1949	4630	On request	-	On request	
		kg	On req.	34	57	72	158	225	560	884	2100	On request	-	On request	
	Class 2500	lbs	On req.	93	163	238	379	604	2198	3990	On request		-	-	
		kg	On req.	42	74	108	172	274	997	1810	On request		-	-	

Table 5.2: Type 3271 and Type 3277 Pneumatic Actuators

Actuator	cm ²	350	355v2	700	750v2	1000	1400-60	1400-120	2800	2 x 2800	
Type 3271 (approx.)	Without handwheel	lbs	18	33	49	80	187	154	386	992	2094
		kg	8	15	22	36	85	70	175	450	950
	With handwheel	lbs	29	44	60	91	419	386	661 ¹⁾ /937 ²⁾	1268 ¹⁾ /1543 ²⁾	On request
		kg	13	20	27	41	190	175	300 ¹⁾ /425 ²⁾	575 ¹⁾ /700 ²⁾	
Type 3277 (approx.)	Without handwheel	lbs	26	42	57	88	-				
		kg	12	19	26	40	-				
	With handwheel	lbs	37	53	68	98	-				
		kg	17	24	31	45	-				

- 1) Side-mounted handwheel up to 80 mm travel
 2) Side-mounted handwheel above 80 mm travel

Table 6: Dimensions and weights for Type 3251 with insulating section · Without actuator

Valve size		NPS	½	1	1½	2	3	4	6	8	10	12	14	16	20						
		DN	15	25	40	50	80	100	150	200	250	300	–	400	500						
Height H4	Class 150 to 600	in	13.9	13.9	14.37	19.17	19.37	20.16	26.18	37.28	42.01	45.32	On req.	44.76	On req.						
		mm	353	353	365	487	492	512	665	947	1067	1151		1137							
	Class 900	in	15.04	15.04	15.39	20.32	19.37	20.16	26.18	37.28	42.01	On req.	–	On request							
mm		382	382	391	516	492	512	665	947	1067	–		On request								
Class 1500 to 2500	in	15.04	15.04	15.39	20.32	21.5	23.54	31.10	42.13	On request		–	Class 1500 On request								
	mm	382	382	391	516	546	598	790	1070			–	Class 1500 On request								
Weight without actuator for	Class 150	lbs	35	40	51	79	130	172	412	1054	2046	2123	On request								
		kg	16	18	23	36	59	78	187	478	928	963									
	Class 300	lbs	42	44	66	108	190	267	774	1054	2046	2123				On request					
		kg	19	20	30	49	86	121	351	478	928	963									
	Class 600	lbs	42	44	66	108	190	267	774	1191	2641	2635							On request		
		kg	19	20	30	49	86	121	351	540	1198	1195									
	Class 900	lbs	42	44	66	108	190	267	774	1254	2657	On req.	–	On request							
		kg	19	20	30	49	86	121	351	569	1205		–	On request							
	Class 1500	lbs	On req.	79	130	172	375	545	1314	2094	On request		–	On request							
		kg		36	59	78	170	247	596	950			–	On request							
	Class 2500	lbs	On req.	97	168	247	401	653	2277	4090	On request		–	–							
		kg		44	76	112	182	296	1033	1855			–	–							

Table 7: Dimensions and weights for Type 3251 with bellows seal · Without actuator

Valve size		NPS	½	1	1½	2	3	4	6	8	10	12	14	16	20		
		DN	15	25	40	50	80	100	150	200	250	300	-	400	500		
		Travel															
Height H4	Class 150	in	14.25	14.25	14.72	23.94	24.13	24.13	27.72								
		mm	362	362	374	608	613	613	704								
	Class 300 to 900	in	14.25	14.25	14.72	23.94	24.13	24.13	32.96								
		mm	362	362	374	608	613	613	837								
	Class 1500	in	0.59	24.92	24.92	25.0	33.62	34.02	On request								
		mm	15	633	633	635	854	864									
		in	1.18	-				33.62	34.02	On request							
		mm	30					854	864								
	Class 2500	in	2.36	-						On req.							
		mm	60														
		in	0.59	24.92	24.92	25.0	On req.	40.16	On request								
		mm	15	633	633	635		1020									
	Class 150 to 300	in	1.18	-				40.16		On request							
		mm	30					1020									
		in	2.36	-						On req.							
		mm	60														
	Class 150 to 300	in	1.18 to 4.72								41.22	59.13	60.20	On req.	59.69	62.60	
		mm	30 to 120								1047	1502	1529		1516	1590	
Class 600 to 900	in	1.18 to 2.36	-							62.24	62.68	64.96	-	On request			
	mm	30 to 60								1581	1592	1650					
Class 600	in	4.72								-	94.65	91.42	On req.	90.16	On req.		
	mm	120									2404	2322		2290			

Valve size		NPS	½	1	1½	2	3	4	6	8	10	12	14	16	20				
		DN	15	25	40	50	80	100	150	200	250	300	-	400	500				
Weight for	Class 150	lbs	46	51	62	97	176	220	430	1146	2150	2227	On request						
		kg	21	23	28	44	80	100	195	520	975	1010							
	Class 300	lbs	53	55	77	126	236	317	794	1146	2150	2227							
		kg	24	25	35	57	107	144	360	520	975	1010							
	Class 600	lbs	53	55	77	126	236	317	794	1312	2740	2734							
		kg	24	25	35	57	107	144	360	595	1243	1240							
	Class 900	lbs	53	55	77	126	236	317	794	1354	2866	On req.					-	On request	
		kg	24	25	35	57	107	144	360	614	1300								
	Class 1500	lbs	On req.	93	174	On req.	414	606	1411	2216	On request						-		
		kg		42	79		188	275	640	1005									
	Class 2500	lbs	On req.	106	201	273	507	714	2337	4222	On request						-		
		kg		48	91	124	230	324	1060	1915									

Selection and sizing of the control valve

1. Calculate the C_v (K_v) coefficient according to IEC 60534-6.
2. Select valve size NPS and C_v (K_v) coefficient from Table 3.
3. Determine the permissible differential pressure from the Information Sheet ► T 8000-4.
4. Select the valve body material from Table 1 and Table 2 as well as from the pressure-temperature diagrams (see Information Sheet ► T 8000-2).
5. Select accessories from Table 1 and Table 2.

Order specifications:

Valve size	NPS
Pressure rating	Class
Body material	Refer to Table 2
Bonnet	Standard bonnet, insulating section or bellows seal
Type of connection	Flanges/welding ends
Plug	Standard or balanced Soft seal, metal seal or high-performance metal seal
Characteristic	Equal percentage, linear or on/off
Actuator	Type 3271 or Type 3277 (see Data Sheets ► T 8310-1, ► T 8310-2 and ► T 8310-3)
Fail-safe position	Fail-close or fail-open
Process medium	Density in lb/cu.ft or kg/m ³ and temperature in °F (°C)
Flow rate	lbs/h or kg/h or cu.ft/min or m ³ /h in standard or operating state
Pressure	p_1 and p_2 in psi (bar) (absolute pressure p_{abs}) (with minimum, normal and maximum flow rate)
RFID tag	Yes/No
Valve accessories	Positioner and/or limit switch

Associated Information Sheet ► T 8000-X
**Associated Data Sheets for
Pneumatic actuators** ► T 8310-1 to -3
Associated Mounting and Operating Instructions ► EB 8052

Note: The temperature limits for DIN and ANSI versions are not directly converted temperatures.