

## Type 3241 Valve

In combination with an actuator,  
e.g. a SAMSON Type 3271 or Type 3277 Pneumatic Actuator

ANSI and JIS version

**SAMSON**

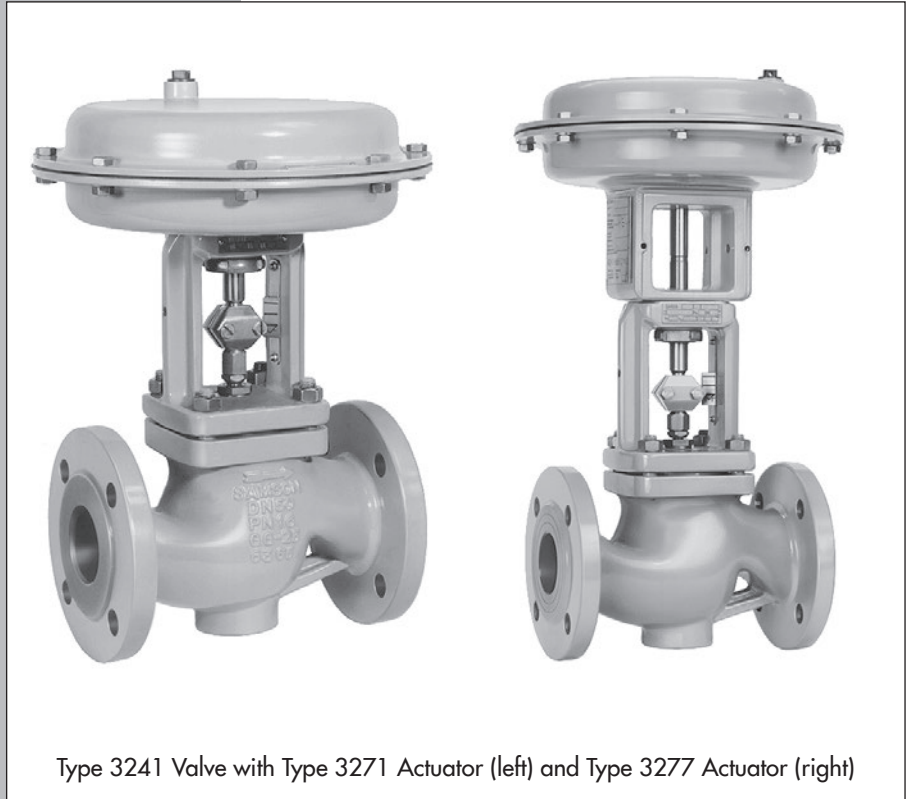

Translation of original instructions

Type 3241 Valve with Type 3271 Actuator (left) and Type 3277 Actuator (right)

## Mounting and Operating Instructions

**EB 8012 EN**

Edition March 2016

**CE**

## Note on these mounting and operating instructions

These mounting and operating instructions assist you in mounting and operating the device safely. The instructions are binding for handling SAMSON devices.

- For the safe and proper use of these instructions, read them carefully and keep them for later reference.
- If you have any questions about these instructions, contact SAMSON's After-sales Service Department (aftersaleservice@samson.de).



The mounting and operating instructions for the devices are included in the scope of delivery. The latest documentation is available on our website ([www.samson.de](http://www.samson.de)) > Product documentation. You can enter the document number or type number in the [Find:] field to look for a document.

## Definition of signal words



### **DANGER!**

*Hazardous situations which, if not avoided, will result in death or serious injury*



### **NOTICE**

*Property damage message or malfunction*



### **WARNING!**

*Hazardous situations which, if not avoided, could result in death or serious injury*



### **Note:**

*Additional information*



### **Tip:**

*Recommended action*

<b>1</b>	<b>Safety instructions and measures .....</b>	<b>5</b>
1.1	Notes on possible severe personal injury .....	7
1.2	Notes on possible personal injury .....	8
1.3	Notes on possible property damage .....	9
<b>2</b>	<b>Markings on the control valve .....</b>	<b>12</b>
2.1	Valve nameplate .....	12
2.2	Actuator nameplate .....	13
2.3	Material number .....	13
<b>3</b>	<b>Design and principle of operation .....</b>	<b>14</b>
3.1	Fail-safe positions .....	16
3.2	Versions .....	16
3.3	Technical data .....	17
<b>4</b>	<b>Preparation .....</b>	<b>24</b>
4.1	Unpacking .....	24
4.2	Transporting and lifting .....	24
4.2.1	Transporting .....	25
4.2.2	Lifting .....	25
4.3	Storage .....	28
4.4	Preparation for installation .....	29
<b>5</b>	<b>Mounting and start-up .....</b>	<b>30</b>
5.1	Mounting the actuator onto the valve .....	30
5.2	Installing the valve into the pipeline .....	31
5.2.1	Checking the installation conditions .....	31
5.2.2	Additional fittings .....	33
5.2.3	Installing the control valve .....	33
5.3	Quick check .....	34
<b>6</b>	<b>Operation .....</b>	<b>36</b>
6.1	Working in manual mode .....	36

<b>7</b>	<b>Maintenance .....</b>	<b>38</b>
7.1	Replacing the gasket .....	39
7.1.1	Standard version.....	39
7.1.2	Version with insulating section or bellows seal .....	41
7.2	Replacing the packing .....	41
7.2.1	Standard version.....	41
7.2.2	Version with insulating section.....	42
7.3	Replacing the seat and plug.....	44
7.3.1	Standard version.....	44
7.3.2	Version with insulating section.....	46
7.4	Preparation for return shipment.....	47
7.5	Ordering spare parts and operating supplies .....	47
<b>8</b>	<b>Malfunctions .....</b>	<b>48</b>
8.1	Troubleshooting .....	48
8.2	Emergency action .....	49
<b>9</b>	<b>Decommissioning and disassembly .....</b>	<b>50</b>
9.1	Decommissioning.....	50
9.2	Removing the valve from the pipeline.....	50
9.3	Removing the actuator from the valve .....	51
9.4	Disposal.....	51
<b>10</b>	<b>Appendix.....</b>	<b>52</b>
10.1	After-sales service .....	52
10.2	Certificates .....	53
10.3	Spare parts .....	59

# 1 Safety instructions and measures

## Intended use

The SAMSON Type 3241 Globe Valve in combination with an actuator (e.g. Type 3271 or Type 3277 Pneumatic Actuator) is designed to regulate the flow rate, pressure or temperature of liquids, gases or vapors. The valve with its actuator is designed to operate under exactly defined conditions (e.g. operating pressure, process medium, temperature). Therefore, operators must ensure that the control valve is only used in applications that meet the specifications used for sizing the valve at the ordering stage. In case operators intend to use the control valve in other applications or conditions than specified, SAMSON must be contacted.

SAMSON does not assume any liability for damage resulting from the failure to use the valve for its intended purpose or for damage caused by external forces or any other external factors.

➔ Refer to the technical data and nameplate for limits and fields of application as well as possible uses.

## Reasonably foreseeable misuse

The control valve is not suitable for the following applications:

- Use outside the limits defined during sizing and in the technical data
- Use outside the limits defined by the valve accessories mounted on the control valve

Furthermore, the following activities do not comply with the intended use:

- Use of non-original spare parts
- Performing service and repair work not described in these instructions

## Qualifications of operating personnel

The control valve must be mounted, started up, serviced, and repaired by fully trained and qualified personnel only; the accepted industry codes and practices are to be observed. According to these mounting and operating instructions, trained personnel refers to individuals who are able to judge the work they are assigned to and recognize possible hazards due to their specialized training, their knowledge and experience as well as their knowledge of the applicable standards.

### Personal protective equipment

We recommend wearing the following protective equipment depending on the process medium:

- Protective clothing, gloves and eyewear in applications with hot, cold, and/or corrosive media
  - Wear hearing protection when working near the valve.
- Check with the plant operator for details on further protective equipment.

### Revisions and other modifications

Revisions, conversions or other modifications to the product are not authorized by SAMSON. They are performed at the user's own risk and may lead to safety hazards, for example. Furthermore, the product may no longer meet the requirements for its intended use.

### Safety devices

Upon supply air or control signal failure, the valve moves to its fail-safe position (see section 3.1). The fail-safe action of the actuator is the same as its direction of action and is specified on the nameplate of SAMSON actuators (see actuator documentation).

### Warning against residual hazards

To avoid personal injury or property damage, plant operators and operating personnel must prevent hazards that could be caused in the control valve by the process medium, the operating pressure, the signal pressure or by moving parts by taking appropriate precautions. They must observe all hazard statements, warning and caution notes in these mounting and operating instructions, especially for installation, start-up, and maintenance.

### Responsibilities of the operator

The operator is responsible for proper operation and compliance with the safety regulations. Operators are obliged to provide these mounting and operating instructions to the operating personnel and to instruct them in proper operation. Furthermore, operators must ensure that operating personnel or third persons are not exposed to any danger.

### Responsibilities of operating personnel

Operating personnel must read and understand these mounting and operating instructions as well as the specified hazard statements, warning, and caution notes. Furthermore, the operating personnel must be familiar with the applicable health, safety and accident prevention regulations and comply with them.

### Referenced standards and regulations

The control valves comply with the requirements of the European Pressure Equipment Directive 97/23/EC. Valves with a CE marking have a declaration of conformity which includes information about the applied conformity assessment procedure. This declaration of conformity is included in the Appendix of these instructions (see section 10.2).

According to the ignition risk assessment performed in accordance with EN 13463-1:2009, section 5.2, the non-electrical control valves do not have their own potential ignition source even in the rare incident of an operating fault. As a result, they do not fall within the scope of Directive 94/9/EC.

→ For connection to the equipotential bonding system, observe the requirements specified in section 6.3 of EN 60079-14:2014-10 (VDE 0165 Part 1).

### Referenced documentation

The following documents apply in addition to these mounting and operating instructions:

- Mounting and operating instructions for mounted actuator, e.g. ► EB 8310-X for Type 3271 and Type 3277 Actuators
- Mounting and operating instructions for mounted valve accessories (positioner, solenoid valve etc.)
- ► AB 0100 for tools and lubricant

## 1.1 Notes on possible severe personal injury



### DANGER!

#### Risk of bursting in pressure equipment.

Control valves and pipelines are pressure equipment. Improper opening can lead to valve components bursting.

- Before starting any work on the control valve, depressurize all plant sections concerned and the valve.
- Drain the process medium from all the plant sections concerned as well as the valve.
- Wear personal protective equipment.

## 1.2 Notes on possible personal injury



### WARNING!

#### **Crush hazard arising from moving parts.**

The control valve contains moving parts (actuator and plug stems), which can injure hands or fingers if inserted into the valve.

- Do not insert hands or finger into the yoke while the valve is in operation.
- While working on the control valve, disconnect and lock the pneumatic air supply as well as the control signal.

#### **Risk of personal injury when the actuator vents.**

While the valve is operating, the actuator may vent during closed-loop control or when the valve opens or closes.

- Install the control valve in such a way that the actuator does not vent at eye level.
- Use suitable silencers and vent plugs.
- Wear eye protection when working in close proximity to the control valve.

#### **Risk of personal injury due to preloaded springs.**

Valves in combination with pneumatic actuators with preloaded springs are under tension. These control valves with SAMSON pneumatic actuators can be identified by the long bolts protruding from the bottom of the actuator.

- Before starting any work on the actuator, relieve the compression from the preloaded springs (see associated actuator documentation).

#### **Risk of personal injury due to residual process medium in the valve.**

While working on the valve, residual process medium can escape and, depending on its properties, may lead to personal injury, e.g. (chemical) burns.

- If possible, drain the process medium from all the plant sections concerned and the valve.
- Wear protective clothing, gloves, and eyewear.



**WARNING!****Risk of burn injuries due to hot or cold components and pipelines.**

Depending on the process medium, valve components, and pipelines may get very hot or cold and cause burn injuries.

- Allow components and pipelines to cool down or heat up.
- Wear protective clothing and gloves.

### 1.3 Notes on possible property damage

**NOTICE****Risk of valve damage due to contamination (e.g. solid particles) in the pipeline.**

The plant engineering company is responsible for cleaning the pipelines in the plant.

- Flush the pipelines before start-up.
- Observe the maximum permissible pressure for valve and plant.

**Risk of valve damage due to unsuitable medium properties.**

The valve is designed for a process medium with defined properties.

- Only use the process medium specified for sizing the valve.

**Risk of leakage and valve damage due to excessively high or low tightening torques.**

Observe the specified torques on tightening control valve components. Excessively tightened torques lead to parts wearing out quicker. Parts that are too loose may cause leakage.

- Observe the specified tightening torques (▶ AB 0100).



## NOTICE

### **Risk of valve damage due to the use of unsuitable tools.**

Certain tools are required to work on the valve.

→ Only use tools approved by SAMSON (▶ AB 0100).

### **Risk of valve damage due to the use of unsuitable lubricants.**

The lubricants to be used depend on the valve material. Unsuitable lubricants may corrode and damage the valve surface.

→ Only use lubricants approved by SAMSON (▶ AB 0100).



## 2 Markings on the control valve

### 2.1 Valve nameplate

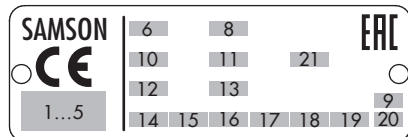
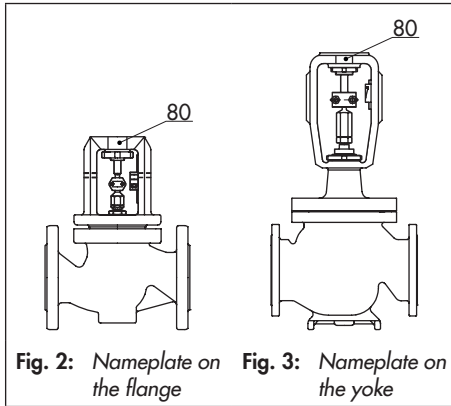

Fig. 1: Valve nameplate

- 1...5 PED (Pressure Equipment Directive), "Art. 3, Abs. 3"  
ID of the notified body, fluid group, and category
- 6 Type designation
- 8 Material
- 9 Year of manufacture
- 10 Valve size:  
DIN: DN · ANSI: NPS · JIS: DN ... A/B
- 11 Pressure rating:  
DIN: PN · ANSI: CL · JIS: K
- 12 Order no. with modification index  
For after-sales service orders: AA prefix
- 13 Position in order  
For after-sales service orders: configuration ID
- 14 Flow coefficient:  
DIN:  $K_{VS}$  · ANSI:  $C_V$  · JIS:  $C_V$
- 15 Characteristic:  
%: equal percentage · Lin: linear · NO/NC: quick opening
- 16 Seat/plug seal:  
ME: metal (see section 3.3)  
HA: carbide metal  
ST: Stellite® facing  
KE: ceramic  
PT: soft seal with PTFE  
PK: soft seal with PEEK
- 17 Seat code (trim material) · On request
- 18 Pressure balancing:  
DIN: D · ANSI: B · JIS: B
- 19 Flow divider:  
1: St I · 3: St III
- 20 Country of origin
- 21 PSA version

The valve nameplate (80) in valve sizes NPS ½ to 6 is affixed to the flange (Fig. 2). The valve nameplate in valve sizes NPS 8 and larger is located on the yoke (Fig. 3).



**Fig. 2:** Nameplate on the flange

**Fig. 3:** Nameplate on the yoke

## 2.2 Actuator nameplate

See associated actuator documentation.

## 2.3 Material number

The seat and plug of the valves have an article number written on them. Specifying this article number, you can contact us to find out which material is used. Additionally, a seat code is used to identify the trim material. This seat code is specified on the nameplate (17). For more details on the nameplate, see section 2.1.

### 3 Design and principle of operation

The single-seated Type 3241 Globe Valve is preferably combined with a SAMSON Type 3271 or Type 3277 Pneumatic Actuator (see Fig. 4). It can also be combined with other actuators.

The seat (4) and plug with plug stem (5) are assembled in the body (1). The plug stem is connected to the actuator stem (A7) by the stem connector clamps (A26) and is sealed by a spring-loaded V-ring packing (16). The springs in the pneumatic actuator (A) are located either above or below the diaphragm depending on the selected fail-safe action (see section 3.1). A change in the signal pressure acting on the diaphragm causes the plug to move. The actuator size is determined by the diaphragm area.

The medium flows through the valve in the direction indicated by the arrow. A rise in signal pressure causes the force acting on the diaphragm in the actuator to increase. The springs are compressed. Depending on the selected direction of action, the actuator stem retracts or extends. As a result, the plug position in the seat changes and determines the flow rate through the valve.

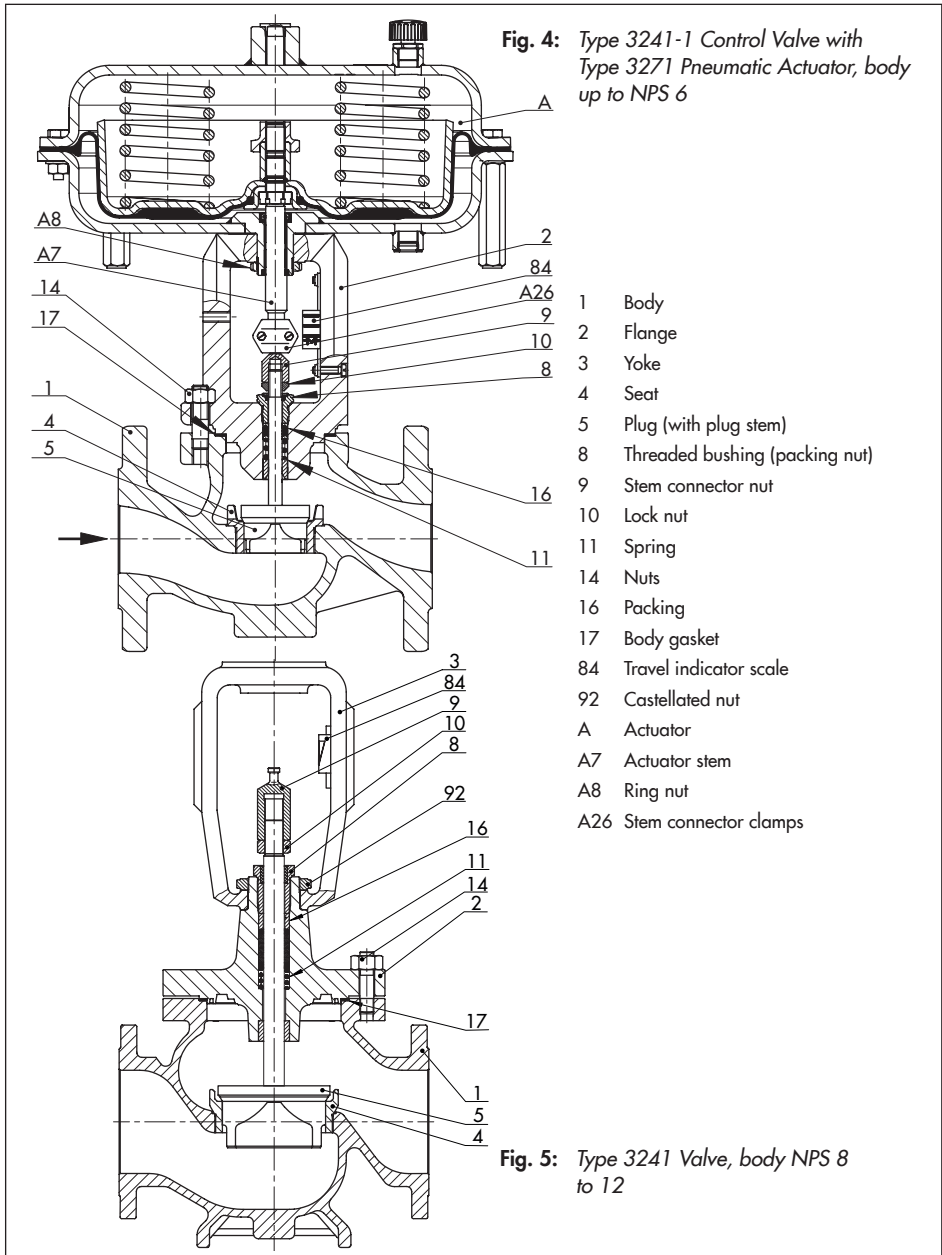

### 3.1 Fail-safe positions

The fail-safe position depends on the actuator used.

Depending on how the compression springs are arranged in the pneumatic actuator, the valve has two different fail-safe positions:

#### Actuator stem extends (FA)

When the signal pressure is reduced or the air supply fails, the springs move the actuator stem downward and close the valve. The valve opens when the signal pressure is increased enough to overcome the force exerted by the springs.

#### Actuator stem retracts (FE)

When the signal pressure is reduced or the air supply fails, the springs move the actuator stem upwards and open the valve. The valve closes when the signal pressure is increased enough to overcome the force exerted by the springs.



**Tip:**

*The actuator's direction of action can be reversed, if required. Refer to the mounting and operating instructions of the pneumatic actuator:*

► EB 8310-X for Type 3271 and Type 3277

### 3.2 Versions

The modular design allows an insulating section or metal bellows to be fitted to the standard valve version.

#### Micro-flow valve version

In the micro-flow valve version, a micro-trim element is installed in the valve body instead of the usual seat/plug assembly (Fig. 6).

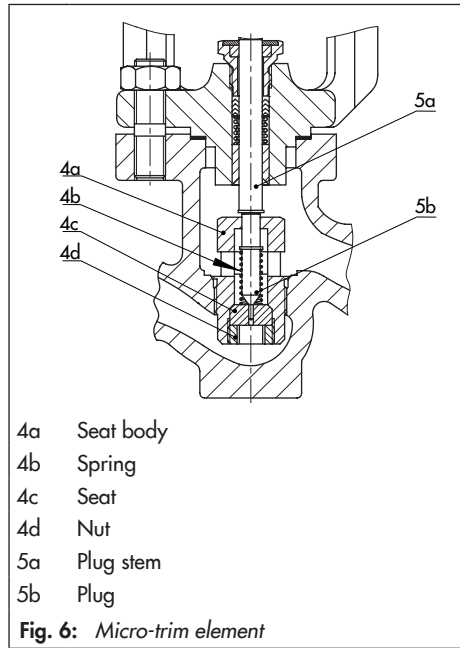



## Actuators

In these instructions, the preferable combination with a Type 3271 or Type 3277 Pneumatic Actuator is described. The pneumatic actuator (with or without handwheel) can be replaced by another pneumatic actuator in a different size, but with the same travel.

→ Observe the maximum permissible actuator force.



**Note:**

*If the travel range of the actuator is larger than the travel range of the valve, the spring assembly in the actuator must be preloaded so that the travel ranges match. See associated actuator documentation.*

The basic pneumatic actuator can be replaced by a pneumatic actuator with additional handwheel or by an electric actuator.

## 3.3 Technical data

The nameplates on the valve and actuator provide information on the control valve version. See section 2.1 and the actuator documentation.



**Note:**

*More information is available in Data Sheet ► T 8012.*

## Compliance

The Type 3241 Valve bears both the CE and EAC marks of conformity.



## Temperature range

Depending on the version, the control valve is designed for a temperature range from -10 to +220 °C (14 to 428 °F). The use of an insulating section or bellows seal extends the temperature range from -196 to +450 °C (-325 to +842 °F).

## Leakage class

Depending on the version, the following leakage class applies:

Seal (16 on nameplate)	ME, ST	ME, ST	PT, PK
Pressure balancing (18 on nameplate)	–	D/B	–
Leakage class (according to ANSI/FCI 70-2)	Min. IV	Min. IV	VI

## Noise emission

SAMSON is unable to make general statements about noise emission as it depends on the valve version, plant facilities, and process medium. On request, SAMSON can perform calculations according to IEC 60534, Part 8-3 and Part 8-4 or VDMA 24422 (edition 89).



**WARNING!**

*Risk of hearing loss or deafness due to loud noise.*

*Wear hearing protection when working near the valve.*

### Dimensions and weights

Table 1 to Table 3 provide a summary of the dimensions and weights of the standard version of Type 3241 Valve. Table 4 and Table 5 show the dimensions and weights for the Type 3241 Valve with insulating section or bellows seal. The lengths and heights in the dimensional drawings are shown on p. 22.

**Table 1:** Dimensions of Type 3241 Valve, up to NPS 6 (DN 150)

Valve		NPS	½	¾	1	1½	2	2½	3	4	6	
		DN	15	20	25	40	50	65	80	100	150	
		NPT	½	¾	1	1½	2	-	-	-	-	
Length L <sup>1)</sup>	Class 125 and 150	in	7.25	7.25	7.25	8.75	10.00	10.88	11.75	13.88	17.75	
		mm	184	184	184	222	254	276	298	352	451	
	Class 300	in	7.50	7.62	7.75	9.25	10.50	11.50	12.50	14.50	18.62	
		mm	190	194	197	235	267	292	318	368	473	
H1 for actua- tor	≤750 cm <sup>2</sup>	in	8.74			8.78		10.31		13.94	15.35	
		mm	222			223		262		354	390	
	1000 cm <sup>2</sup> 1400-60 cm <sup>2</sup>	in	-							16.26	17.72	
		mm	-							413	450	
	1400- 120 cm <sup>2</sup> 2800 cm <sup>2</sup>	in	-									
		mm	-									
H2 for version	Cast steel	in	1.73	1.73	1.73	2.83	2.83	3.86	3.86	4.65	6.89	
		mm	44	44	44	72	72	98	98	118	175	
	Forged steel	in	2.1	-	2.76	3.62	3.86	-	5.05	-	-	
		mm	53	-	70	92	98	-	128	-	-	

<sup>1)</sup> Face-to-face dimensions according to ANSI/ISA 75.08.01

**Table 2:** Dimensions of Type 3241 Valve, NPS 8 (DN 200) and larger

Valve	NPS		8	10	10	10	12
	DN		200	250/cast iron	250 up to 200 mm seat bore	250 seat bore 250 mm and larg- er	300
Length L <sup>1)</sup>	Class 125 and 150	in	21.38	26.50	26.50	26.50	29.00
		mm	543	673	673	673	737
	Class 300	in	22.38	27.88	27.88	27.88	30.50
		mm	568	708	708	708	775
H4	in	15.35	15.35	17.76	17.76	25.67	
	mm	390	390	451	451	652	
H8 <sup>2)</sup> for ac- tuator	1000 cm <sup>2</sup> 1400- 60 cm <sup>2</sup>	in	16.46	16.46	16.46	19.80	19.80
		mm	418	418	418	503	503
	1400- 120 cm <sup>2</sup> 2800 cm <sup>2</sup>	in	19.80	19.80	19.80	25.59	25.59
		mm	503	503	503	650	650
H2	in	9.65	10.63	12.20	12.20	14.57	
	mm	245	270	310	310	370	

<sup>1)</sup> Face-to-face dimensions according to ANSI/ISA 75.08.01

<sup>2)</sup> H8 increases by 6.69" (170 mm) for valves with C<sub>v</sub> 290, 420 or 735 (K<sub>vS</sub> 250, 360 or 630) and 60 mm rated travel operating with overtravel

**Table 3:** Weights for Type 3241 Valve

Valve	NPS		½	¾	1	1½	2	2½	3	4	6	8	10	12
	DN		15	20	25	40	50	65	80	100	150	200	250	300
Weight with- out actuator	lbs	15	18	20	35	44	71	82	137	287	1096	1892	2535	
	kg	7	8	9	16	20	32	37	62	130	497	858	1150	

**Table 4:** Dimensions and weights for the Type 3241 Valve with insulating section or bellows seal up to NPS 6 (DN 150)

Valve size		NPS	½	¾	1	1½	2	2½	3	4	6
		DN	15	20	25	40	50	65	80	100	150
Insulating section or bellows seal											
H4 for actuator	≤750 cm <sup>2</sup>	Short	in	16.10		16.14		17.76		25.04	26.46
			mm	409		410		451		636	672
	Long	in	28.07		28.11		29.72		34.53	35.94	
		mm	713		714		755		877	913	
	1000 cm <sup>2</sup> 1400-60 cm <sup>2</sup>	Short	in	-						27.36	28.82
			mm	-						695	732
	Long	in	-						36.85	38.31	
		mm	-						936	973	
	1400-120 cm <sup>2</sup> / 2800 cm <sup>2</sup>	Short Long	in	-							
			mm	-							
Weight without actuator (approx.)	Short	lbs	22	24	26	49	57	88	99	176	353
		kg	10	11	12	22	26	40	45	80	160
	Long	lbs	31	33	35	57	66	97	108	194	370
		kg	14	15	16	26	30	44	49	88	168

**Table 5:** Dimensions and weights for the Type 3241 Valve with insulating section or bellows seal for NPS 8 (DN 200) and larger

Version with		Insulating section				Bellows seal				
Valve size	NPS	8	10 Up to 200 mm seat bore	10 250 mm seat bore	12	8	10 Up to 200 mm seat bore	10 250 mm seat bore	12	
	DN	200	250 Up to 200 mm seat bore	250 250 mm seat bore	300	200	250 Up to 200 mm seat bore	250 250 mm seat bore	300	
H4 for actua- tor	1000 cm <sup>2</sup> 1400- 60 cm <sup>2</sup>	in	32.7	41.9	–	45.3	40.8	58.7	–	59.8
		mm	830	1065	–	1150	1036	1492	–	1520
	1400- 120 cm <sup>2</sup> 2800 cm <sup>2</sup>	in	32.7	41.9	41.9	45.3	40.8	58.7	58.7	59.8
		mm	830	1065	1065	1150	1036	1492	1492	1520
H8 for actua- tor	1000 cm <sup>2</sup> 1400- 60 cm <sup>2</sup>	in	16.5	16.5	19.8	19.8	16.5	16.5	19.8	19.8
		mm	418	418	503	503	418	418	503	503
	1400- 120 cm <sup>2</sup> 2800 cm <sup>2</sup>	in	19.8	19.8	25.6	25.6	19.8	19.8	25.6	25.6
		mm	503	503	650	650	503	503	650	650
Weight without actuator (approx.)	lbs	1191	2220	2220	2690	1312	2407	2407	2793	
	kg	540	1007	1007	1220	595	1092	1092	1267	

Dimensional drawings

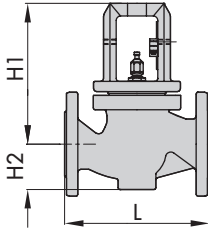

Type 3241 · NPS ½ to 6 (DN 15 to 150)

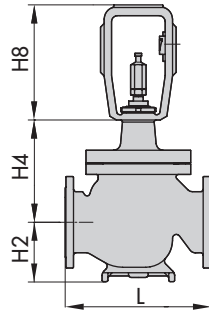

Type 3241 · NPS 8 to 12 (DN 200 to 300)

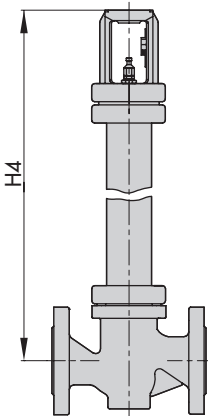

Type 3241 with insulating section or bellows seal · NPS ½ to 6 (DN 15 to 150)

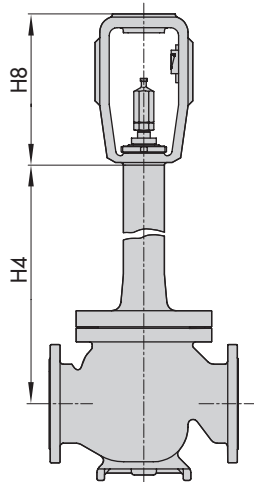

Type 3241 with insulating section or bellows seal · NPS 8 to 12 (DN 200 to 300)



**Note:**

Refer to the following data sheets for more dimensions and weights:

▶ T 8012 for valves with bellows seal, insulating section or heating jacket

The associated actuator documentation applies to actuators, e.g. for SAMSON pneumatic actuators:

▶ T 8310-1 for Type 3271 and Type 3277 Actuators up to 750 cm<sup>2</sup> actuator area

▶ T 8310-2 for Type 3271 Actuator with 1000 cm<sup>2</sup> actuator area and larger

▶ T 8310-3 for Type 3271 Actuator with 1400-60 cm<sup>2</sup> actuator area

## 4 Preparation

After receiving the shipment, proceed as follows:

1. Check the scope of delivery. Compare the shipment received against the delivery note.
2. Check the shipment for transportation damage. Report any damage to SAMSON and the forwarding agent (refer to delivery note).

### 4.1 Unpacking



**Note:**

*Do not remove the packaging until immediately before installing the valve into the pipeline.*

Proceed as follows to lift and install the valve:

1. Remove the packaging from the valve.
2. Dispose of the packaging in accordance with the valid regulations.



**NOTICE**

*Risk of valve damage due to foreign particles entering the valve. The protective caps fitted on the valve's inlet and outlet prevent foreign particles from entering the valve and damaging it. Do not remove the protective caps until immediately before installing the valve into the pipeline.*

### 4.2 Transporting and lifting



**DANGER!**

*Hazard due to suspended loads falling. Stay clear of suspended or moving loads.*



**WARNING!**

*Risk of lifting equipment tipping and risk of damage to lifting accessories due to exceeding the rated lifting capacity.*

- Only use approved lifting equipment and accessories whose minimum lifting capacity is higher than the weight of the valve (including actuator, if applicable).
- Refer to section 3.3 or Data Sheet ► T 8012 for weights.



**WARNING!**

*Risk of personal injury due to control valve tipping.*

- Observe the valve's center of gravity.
- Secure the valve against tipping over or turning.



**!** **NOTICE**

- Risk of valve damage due to incorrectly attached slings. The welded-on lifting eyelet on SAMSON actuators is only intended for mounting and removing the actuator as well as lifting the actuator without valve. Do not use this lifting eyelet to lift the entire control valve assembly.*
- *When lifting the control valve, make sure that the slings attached to the valve body bear the entire load.*
  - *Do not attach load-bearing slings to the actuator, handwheel or any other parts.*
  - *Observe lifting instructions (see section 4.2.2).*



**Tip:** SAMSON's After-sales Service department can provide more detailed transport and lifting instructions on request.

**4.2.1 Transporting**

The control valve can be transported using lifting equipment (e.g. crane or forklift).

- ➔ Leave the control valve in its transport container or on the pallet to transport it.
- ➔ Observe the transport instructions.

**Transport instructions**

- Protect the control valve against external influences (e.g. impact).
- Do not damage the corrosion protection (paint, surface coatings). Remove any damage immediately.
- Protect the control valve against moisture and dirt.
- The permissible transportation temperature of standard control valves is  $-20$  to  $+65$  °C ( $-4$  to  $+149$  °F).

**Note:**

Contact SAMSON's After-sales Service department for the transportation temperatures of other valve versions.

**4.2.2 Lifting**

To install a large valve into the pipeline, use lifting equipment (e.g. crane or forklift) to lift it.

**Lifting instructions**

- Secure slings against slipping.
- Make sure the slings can be removed from the valve once it has been installed into the pipeline.

## Preparation

- Prevent the control valve from tilting or tipping.
- Do not leave loads suspended when interrupting work for longer periods of time.
- Make sure that the axis of the pipeline is always horizontal during lifting and the axis of the plug stem is always vertical.
- Make sure that the additional sling between the lifting eyelet and rigging equipment (hook, shackle etc.) does not bear any load when lifting valves larger

than NPS 6. The sling only protects the control valve from tilting while being lifted. Before lifting the control valve, tighten the sling.

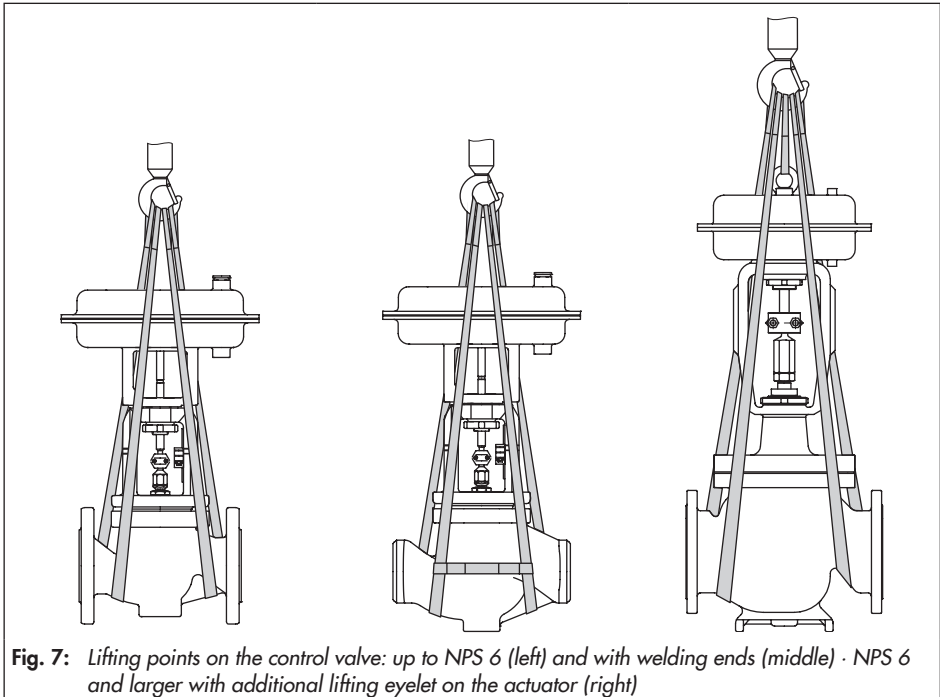

### Version with flanges

1. Attach one sling to each flange of the body and to the rigging equipment (e.g. hook) of the crane or forklift (see Fig. 7).
2. **NPS 6 and larger:** Attach another sling to the lifting eyelet on the actuator and to the rigging equipment.
3. Carefully lift the control valve. Check whether the lifting equipment and accessories can bear the weight.
4. Move the control valve at an even pace to the site of installation.
5. Install the valve into the pipeline (see section 5.2.3).
6. After installation in the pipeline, check whether the flanges are bolted tight and the valve in the pipeline holds.
7. Remove slings.

### Version with welding ends

1. Attach one sling to each welding end of the body and to the rigging equipment (e.g. hook) of the crane or forklift (see Fig. 7).
2. Secure the slings attached to the body against slipping using a connector.
3. **NPS 6 and larger:** Attach another sling to the lifting eyelet on the actuator and to the rigging equipment.
4. Carefully lift the control valve. Check whether the lifting equipment and accessories can bear the weight.
5. Move the control valve at an even pace to the site of installation.
6. Install the valve into the pipeline (see section 5.2.3).
7. After installation in the pipeline, check whether the weld seams hold.
8. Remove connector and slings.



#### **Tip:**

*We recommend using a hook with safety latch (see Fig. 7). The safety latch prevents the slings from slipping during lifting and transporting.*

---

## 4.3 Storage



### **NOTICE**

*Risk of valve damage due to improper storage.*

- *Observe storage instructions.*
- *Avoid long storage times.*
- *Contact SAMSON in case of different storage conditions or longer storage times.*



### **Note:**

*We recommend regularly checking the control valve and the prevailing storage conditions during long storage times.*

### **Storage instructions**

- Protect the control valve against external influences (e.g. impact).
- Do not damage the corrosion protection (paint, surface coatings). Remove any damage immediately.
- Protect the control valve against moisture and dirt. Store it at a relative humidity of less than 75 %. In damp spaces, prevent condensation. If necessary, use a drying agent or heating.
- Make sure that the ambient air is free of acids or other corrosive media.
- The permissible storage temperature of standard control valves is  $-20$  to  $+65$  °C ( $-4$  to  $+149$  °F).



### **Note:**

*Contact SAMSON's After-sales Service department for the storage temperatures of other valve versions.*

- Do not place any objects on the control valve.

### **Special storage instructions for elastomers**

Elastomer, e.g. actuator diaphragm

- To keep elastomers in shape and to prevent cracking, do not bend them or hang them up.
- We recommend a storage temperature of  $15$  °C ( $59$  °F) for elastomers.
- Store elastomers away from lubricants, chemicals, solutions, and fuels.



### **Tip:**

*SAMSON's After-sales Service department can provide more detailed storage instructions on request.*

## 4.4 Preparation for installation

Proceed as follows:

- Flush the pipelines.



**Note:**

*The plant engineering company is responsible for cleaning the pipelines in the plant.*

---

- Check the valve to make sure it is clean.
- Check the valve for damage.
- Check to make sure that the type designation, valve size, material, pressure rating and temperature range of the valve match the plant conditions (size and pressure rating of the pipeline, medium temperature etc.).
- For steam applications, make sure that the pipelines are dry. Moisture will damage the inside of the valve.
- Check any mounted pressure gauges to make sure they function.
- When the valve and actuator are already assembled, check the tightening torques of the bolted joints (▶ AB 0100). Components may loosen during transport.

### 5 Mounting and start-up

SAMSON valves are delivered ready for use. In special cases, the valve and actuator are delivered separately and must be assembled on site. The procedure to mount and start up the valve are described in the following.



#### **NOTICE**

*Risk of valve damage due to excessively high or low tightening torques. Observe the specified torques on tightening control valve components. Excessively tightened torques lead to parts wearing out quicker. Parts that are too loose may cause leakage. Observe the specified tightening torques (▶ AB 0100).*



#### **NOTICE**

*Risk of valve damage due to the use of unsuitable tools. Only use tools approved by SAMSON (▶ AB 0100).*

### 5.1 Mounting the actuator onto the valve

Proceed as described in the actuator documentation if the valve and actuator have not been assembled by SAMSON:

#### **Versions with V-port plug**

Each V-port plug has three V-shaped ports. Depending on the valve size, the size of the symmetrically arranged V-shaped ports varies. The process medium in the valve flows through the V-shaped ports as soon as the plug is lifted out of the seat (i.e. the valve opens).

1. Before mounting the actuator, determine which V-shaped port is uncovered first when the plug is lifted out of the seat.



#### **Tip:**

*Usually, this is the largest V-shaped port.*

2. On mounting the actuator, make sure that the V-shaped port uncovered first faces toward the valve outlet.



#### **NOTICE**

*Risk of damage to wall of valve body due to incorrectly diverted jet stream. The process medium cannot flow unobstructed through the valve when the V-port plug has been installed incorrectly. This will result in the process medium hitting the body wall, which may lead to severe valve damage. Make sure the V-port plug is installed correctly.*

**Note:**

- Remove the mounted actuator before mounting the other actuator (see associated actuator documentation).
- Preloading the actuator springs increases the thrust of a pneumatic actuator and reduces the travel range of the actuator (see associated actuator documentation).

## 5.2 Installing the valve into the pipeline

### 5.2.1 Checking the installation conditions

#### Pipeline routing

The inlet and outlet lengths vary depending on the process medium. To ensure the control valve functions properly, follow the installation instructions given below:

- Observe the inlet and outlet lengths (see Table 6). Contact SAMSON if the valve conditions or states of the medium process deviate.
- Install the valve free of stress and with the least amount of vibrations as possible. If necessary, attach supports to the valve.
- Install the valve allowing sufficient space to remove the actuator and valve or to perform service and repair work on them.

#### Mounting position

Generally, we recommend installing the valve with the actuator upright and on top of the valve.

In the following versions, the valve **must** be installed with the actuator on top:

- Valves in NPS 4 and larger
  - Valves with insulating section for low temperatures below  $-10\text{ }^{\circ}\text{C}$  ( $14\text{ }^{\circ}\text{F}$ )
- Contact SAMSON if the mounting position is not as specified here.

#### Support or suspension

Depending on the valve version and mounting position, the control valve and pipeline must be supported or suspended. The plant engineering company is responsible in this case.

**NOTICE**

*Premature wear and leakage due to insufficient support or suspension. In the following versions, the control valve must be supported or suspended:*

- *Valves that are not installed with the actuator upright on top of the valve.*
- Attach a suitable support or suspension to the valve.*

Table 6: Inlet and outlet lengths

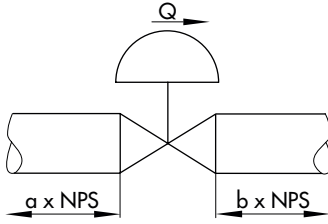

Q Flow rate  
a Inlet length  
b Outlet length

State of process medium	Valve conditions	Inlet length a	Outlet length b
Gas	$Ma \leq 0.3$	2	4
	$0.3 \leq Ma \leq 0.7$	2	10
Vapor	$Ma \leq 0.3$ <sup>1)</sup>	2	4
	$0.3 \leq Ma \leq 0.7$ <sup>1)</sup>	2	10
	Saturated steam (percentage of condensate > 5 %)	2	20
Liquid	Free of cavitation/ $w < 10$ m/s	2	4
	Cavitation producing noise/ $w \leq 3$ m/s	2	4
	Cavitation producing noise/ $3 < w < 5$ m/s	2	10
	Critical cavitation/ $w \leq 3$ m/s	2	10
	Critical cavitation/ $3 < w < 5$ m/s	2	20
Flashing	–	2	20
Multi-phase	–	10	20

<sup>1)</sup> No saturated steam

### Vent plug

Vent plugs are screwed into the exhaust air ports of pneumatic and electropneumatic devices. They ensure that any exhaust air that forms can be vented to the atmosphere (to avoid excess pressure in the device). Furthermore, the vent plugs allow air intake to prevent a vacuum from forming in the device.

→ Locate the vent plug on the opposite side to the workplace of operating personnel.

→ On mounting valve accessories, make sure that they can be operated from the workplace of the operating personnel.



**Note:**

The workplace of operating personnel is the location from which the valve, actuator and any mounted valve accessories can be accessed to operate them.



## 5.2.2 Additional fittings

### Strainers

We recommend installing a SAMSON strainer upstream of the valve. It prevents solid particles in the process medium from damaging the valve.

### Bypass and shut-off valves

We recommend installing a shut-off valve both upstream of the strainer and downstream of the valve and setting up a bypass line. The bypass line ensures that the plant does not need to be shut down for service and repair work on the valve.

### Insulation

Only insulate control valves with insulating section or bellows seal up to the bonnet flange of the valve body for medium temperatures below 0 °C (32 °F) and above 220 °C (428 °F).

Do not insulate valves mounted to comply with NACE MR 0175 requirements.

### Test connection

Versions with bellows seal fitted with a test connection (G 1/8) at the top flange allow the tightness of the bellows to be monitored.

Particularly for liquids and vapors, we recommend installing a suitable leakage indicator (e.g. a contact pressure gauge, an outlet to an open vessel or an inspection glass).



### **WARNING!**

*Risk of personal injury due to components under pressure and process medium escaping under pressure. Do not loosen the screw of the test connection while the valve is in operation.*

### Safety guard

To reduce the crush hazard arising from moving parts (actuator and plug stem), a safety guard can be installed.

### Noise emission

Trims with flow dividers can be used to reduce noise emission (see ► T 8081).

## 5.2.3 Installing the control valve

### Version with flanges

1. Close the shut-off valve in the pipeline while the valve is being installed.
2. Remove the protective caps from the valve ports before installing the valve.
3. Lift the valve using suitable lifting equipment to the site of installation (see section 4.2.2). Observe the flow direction through the valve. The arrow on the valve indicates the direction of flow.
4. Make sure that the correct flange gaskets are used.
5. Bolt the pipe to the valve free of stress.

- Depending on the field of application, allow the valve to cool down or heat up to reach ambient temperature before start up.
- Slowly open the shut-off valve in the pipeline after the valve has been installed.



### **NOTICE**

*Risk of valve damage due to a sudden pressure increase and resulting high flow velocities.*

*Slowly open the shut-off valve in the pipeline during start-up.*

---

- Check the valve to ensure it functions properly.

### **Version with welding ends**

- Proceed as described for "Version with flanges" (steps 1 to 3).
- Completely retract the actuator stem to protect the plug from sparks during welding.
- Weld the valve free of stress into the pipeline.
- Proceed as described for "Version with flanges" (steps 6 to 8).

## 5.3 Quick check

SAMSON valves are delivered ready for use. To test the valve's ability to function, the following quick checks can be performed:

### **Tight shut-off**

- Close the valve.
- Slowly open the shut-off valve in the pipeline.



### **NOTICE**

*Risk of valve damage due to a sudden pressure increase and resulting high flow velocities.*

*Slowly open the shut-off valve in the pipeline during start-up.*

---

- Check the valve for leakage to the atmosphere (visual inspection).

### **Travel motion**

The movement of the actuator stem must be linear and smooth.

- Open and close the valve, observing the movement of the actuator stem.
- Apply the maximum and minimum control signals to check the end positions of the valve.
- Check the travel reading at the travel indicator scale.

### Fail-safe position

- Shut off the signal pressure line.
- Check whether the valve moves to the fail-safe position.

### Adjustable packing



**Tip:**

*A label on the flange (2) or yoke (3) indicates whether an adjustable packing is installed.*

1. Tighten the threaded bushing gradually (by turning it clockwise) until the packing seals the valve.



**NOTICE**

*Risk of valve damage due to the threaded bushing tightened too far. Make sure that the plug stem can still move smoothly after the threaded bushing has been tightened.*

2. Open and close the valve several times.
3. Check the valve for leakage to the atmosphere (visual inspection).
4. Repeat steps 1 and 2 until the packing completely seals the valve.



**Note:**

*If the adjustable packing does not seal properly, contact SAMSON's After-sales Service department.*

- Retract the plug stem to open the valve.
- Observe the maximum permissible pressure for valve and plant.



**Note:**

*The plant engineering company is responsible for performing the pressure test. SAMSON's After-sales Service department can support you to plan and perform a pressure test for your plant.*

### Pressure test

During the pressure test, make sure the following conditions are met:

## 6 Operation

Immediately after completing mounting and start-up (see section 5), the valve is ready for use.



### **WARNING!**

*Crush hazard arising from moving parts (actuator and plug stem).  
Do not insert hands or finger into the yoke while the valve is in operation.*

---



### **WARNING!**

*Risk of personal injury when the actuator vents.  
Wear eye protection when working in close proximity to the control valve.*

---



### **WARNING!**

*Risk of burn injuries due to hot or cold components and pipelines.  
Depending on the process medium, valve components, and pipelines may get very hot or cold and cause burn injuries.  
Wear protective clothing and gloves.*

---



### **NOTICE**

*Operating disturbed by a blocked actuator and plug stem.  
Do not impede the movement of the actuator or plug stem by inserting objects into their path.*

---

## 6.1 Working in manual mode

Valves fitted with actuators with a handwheel can be manually closed or opened in case of supply air failure.

→ For normal closed-loop operation, move the handwheel to the neutral position.



## 7 Maintenance

The control valve is subject to normal wear, especially at the seat, plug, and packing. Depending on the operating conditions, check the valve at regular intervals to prevent possible failure before it can occur.



**Tip:**

SAMSON's After-sales Service department can support you to draw up a maintenance plan for your plant.

We recommend removing the valve from the pipeline or service or repair work (see section 9.2).



**DANGER!**

*Risk of bursting in pressure equipment.*

*Control valves and pipelines are pressure equipment. Improper opening can lead to bursting of the valve.*

- Before starting any work on the control valve, depressurize all plant sections concerned and the valve.
- Drain the process medium from all the plant sections concerned as well as the valve.
- Wear personal protective equipment.



**WARNING!**

*Risk of personal injury due to residual process medium in the valve. While working on the valve, residual process medium can escape and, de-*

*pending on its properties, may lead to personal injury, e.g. (chemical) burns.*

*Wear protective clothing, gloves, and eyewear.*



**WARNING!**

*Risk of burn injuries due to hot or cold components and pipeline. Valve components and the pipeline may become very hot or cold. Risk of burn injuries.*

- Allow components and pipelines to cool down or heat up.
- Wear protective clothing and gloves.



**NOTICE**

*Risk of valve damage due to incorrect maintenance or repair. Service and repair work must only be performed by trained staff.*



**NOTICE**

*Risk of valve damage due to excessively high or low tightening torques. Observe the specified torques on tightening control valve components. Excessively tightened torques lead to parts wearing out quicker. Parts that are too loose may cause leakage. Observe the specified tightening torques (▶ AB 0100).*

**NOTICE**

Risk of valve damage due to the use of unsuitable tools.

Only use tools approved by SAMSON (▶ AB 0100).

**NOTICE**

Risk of valve damage due to the use of unsuitable lubricants.

Only use lubricants approved by SAMSON (▶ AB 0100).

**Note:**

The control valve was checked by SAMSON before it left the factory.

- Certain test results (seat leakage and leak test) certified by SAMSON lose their validity when the valve body or actuator housing is opened.
- The product warranty becomes void if maintenance or repair work not described in these instructions is performed without prior agreement by SAMSON's After-sales Service department.
- Only use original spare parts by SAMSON, which comply with the original specifications.

## 7.1 Replacing the gasket

**NOTICE**

Risk of control valve damage due to incorrect service or repair.

The gasket can only be replaced when all the following conditions are met:

- The valve size is  $\leq$ NPS 6.
- The valve does not have a balanced plug.

To replace the gasket in other valve versions, contact SAMSON's After-sales Service department.

### 7.1.1 Standard version

1. Remove the actuator from the valve. See associated actuator documentation.
2. Undo the body nuts (14) gradually in a criss-cross pattern.
3. Lift the flange (2) and plug with plug stem (5) off the body (1).
4. Remove gasket (17). Carefully clean the sealing faces in the valve body (1) and on the flange (2).
5. Insert a new gasket (17) into the body.
6. Place the flange (2) onto the body.
 

**Version with V-port plug:** place the flange (2) onto the valve body, making sure that the largest V-shaped port of the V-port plug faces toward the valve outlet. See section 5.1.
7. Press the plug (5) firmly into the seat (4), while fastening down the flange (2) with the body nuts (14). Tighten the nuts

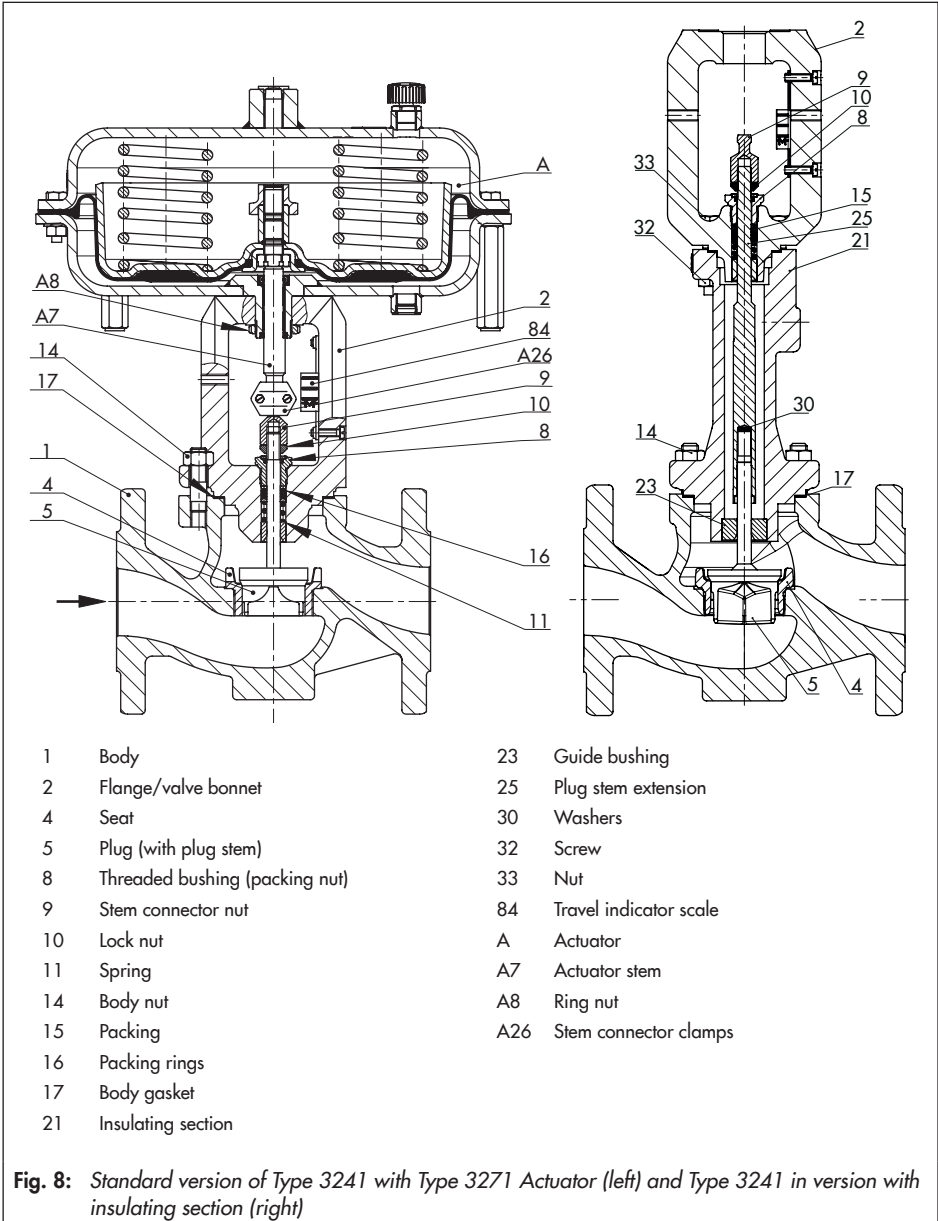



- gradually in a criss-cross pattern. Observe tightening torques.
8. Mount actuator. See associated actuator documentation.
  9. Adjust lower or upper signal bench range. See associated actuator documentation.

### 7.1.2 Version with insulating section or bellows seal

1. Remove the actuator from the valve. See associated actuator documentation.
2. Undo the body nuts (14) gradually in a criss-cross pattern.
3. Lift the insulating section (21) with valve bonnet (2) and plug with plug stem (5) off the body (1).
4. Remove gasket (17). Carefully clean the sealing faces in the valve body (1) and on the insulating section (21).
5. Insert a new gasket (17) into the body.
6. Place the insulating section (21) with valve bonnet (2) and plug with plug stem (5) onto the body.
 

**Version with V-port plug:** place the assembly onto the valve body, making sure that the largest V-shaped port of the V-port plug faces toward the valve outlet. See section 5.1.
7. Press the plug (5) firmly into the seat (4), while fastening down the insulating section (21) with the body nuts (14). Tighten the nuts gradually in a criss-cross pattern. Observe tightening torques.

8. Mount actuator. See associated actuator documentation.
9. Adjust lower or upper signal bench range. See associated actuator documentation.

## 7.2 Replacing the packing



### NOTICE

*Risk of control valve damage due to incorrect service or repair. The packing can only be replaced when all the following conditions are met:*

- *The valve size is  $\leq$ NPS 6.*
  - *The valve does not have a balanced plug.*
  - *The valve does not have a bellows seal.*
  - *The standard or ADSEAL packing is installed in the valve.*
- To replace the packing in other valve versions, contact SAMSON's After-sales Service department.*
-

## 7.2.1 Standard version

### Standard packing (PTFE)

1. Remove the actuator from the valve. See associated actuator documentation.
2. Undo the body nuts (14) gradually in a criss-cross pattern.
3. Lift the flange (2) and plug with plug stem (5) off the body (1).
4. Unthread the stem connector nut (9) and lock nut (10) from the plug stem.
5. Unscrew the threaded bushing (8).
6. Pull the plug with plug stem (5) out of the flange (2).
7. Pull all the packing parts out of the packing chamber using a suitable tool.
8. Renew damaged parts. Clean the packing chamber thoroughly.
9. Apply a suitable lubricant to all the packing parts and to the plug stem (5).
10. Slide the plug with plug stem (5) into the valve body (1).
11. Place the flange (2) onto the body.  
**Version with V-port plug:** place the flange (2) onto the valve body, making sure that the largest V-shaped port of the V-port plug faces toward the valve outlet. See section 5.1.
12. Carefully slide the packing parts over the plug stem into the packing chamber using a suitable tool. Make sure to observe the proper sequence (see Fig. 9).

13. Press the plug (5) firmly into the seat (4), while fastening down the flange (2) with the body nuts (14). Tighten the nuts gradually in a criss-cross pattern. Observe tightening torques.
14. Screw in the threaded bushing (8) and tighten it. Observe tightening torques.
15. Loosely screw the lock nut (10) and stem connector nut (9) onto the plug stem.
16. Mount actuator. See associated actuator documentation.
17. Adjust lower or upper signal bench range. See associated actuator documentation.

### ADSEAL packing

1. Proceed as described in "Standard packing (PTFE)", steps 1 to 11.
2. Slide the parts of the packing over the plug stem in the specified order:
  - Spring (11)
  - Washer (12)
  - Packing rings (16)
3. Slide the seals (15.2) over the plug stem. Insert the wire of the red spacer ring (15.1) into the groove of the retaining ring. Slide the retaining ring over the plug stem.
4. Insert the red spacer ring (15.1) between the threaded bushing (8) and retaining ring. See Fig. 9.
5. Proceed as described in "Standard packing (PTFE)", steps 13 to 17.

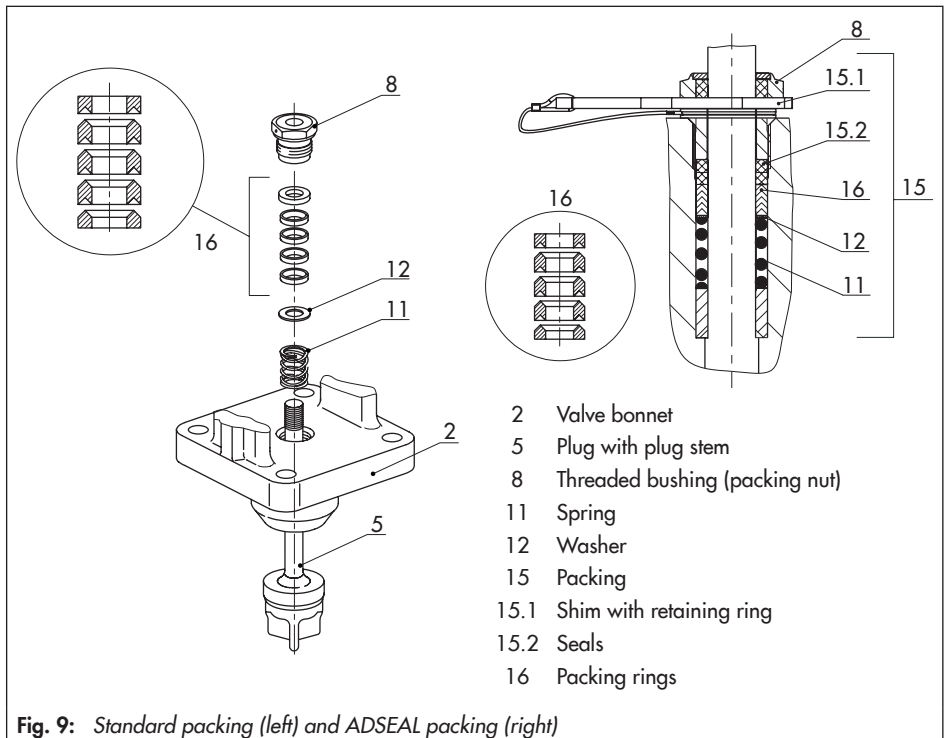

Fig. 9: Standard packing (left) and ADSEAL packing (right)

## 7.2.2 Version with insulating section

### Standard packing (PTFE)

1. Remove the actuator from the valve. See associated actuator documentation.
2. Unthread the stem connector nut (9) and lock nut (10) from the plug stem extension (25).
3. Unscrew the threaded bushing (8).
4. Remove nuts (33) and bolts (32).
5. Carefully lift the valve bonnet (2) over the plug stem extension (25).
6. Pull all the packing parts out of the packing chamber using a suitable tool.
7. Renew the damaged parts and carefully clean the packing chamber.
8. Apply a suitable lubricant to all the packing parts and to the plug stem extension (25).
9. Carefully lift the valve bonnet (2) over the plug stem extension (25) onto the insulating section (21).

**Version with V-port plug:** place the valve bonnet (2) onto the insulating section, making sure that the largest V-shaped port of the V-port plug faces toward the valve outlet. See section 5.1.

- Carefully slide the packing parts over the plug stem extension into the packing chamber using a suitable tool. Make sure to observe the proper sequence (see Fig. 9).
- Fasten the valve bonnet with nuts (33) and bolts (32). Observe tightening torques.
- Screw in the threaded bushing (8) and tighten it. Observe tightening torques.
- Loosely screw the lock nut (10) and stem connector nut (9) onto the plug stem.
- Mount actuator. See associated actuator documentation.
- Adjust lower or upper signal bench range. See associated actuator documentation.

### ADSEAL packing

- Proceed as described in "Standard packing (PTFE)", steps 1 to 9.
- Slide the parts of the packing over the plug stem extension in the specified order:
  - Spring (11)
  - Washer (12)
  - Packing rings (16)
- Slide the seals (15.2) over the plug stem extension.  
Insert the wire of the red spacer ring (15.1) into the groove of the retaining ring.

Slide the retaining ring over the plug stem extension.

- Insert the red spacer ring (15.1) between the threaded bushing (8) and retaining ring. See Fig. 9.
- Proceed as described in "Standard packing (PTFE)", steps 11 to 15.

## 7.3 Replacing the seat and plug

---

### NOTICE

*Risk of control valve damage due to incorrect service or repair. Seat and plug can only be replaced when all the following conditions are met:*

- The valve size is  $\leq$ NPS 6.*
- The valve does not have a balanced plug.*
- The valve does not have a bellows seal.*
- The standard or ADSEAL packing is installed in the valve.*

*To replace seat and plug in other valve versions, contact SAMSON's After-sales Service department.*

---

### NOTICE

*Risk of damage to the facing of the seat and plug due to incorrect service or repair.*

*Always replace both the seat and plug.*

---

**Tip:**

*When replacing the seat and plug, we also recommend replacing the packing. See section 7.2.*

### 7.3.1 Standard version

1. Remove the actuator from the valve. See associated actuator documentation.
2. Undo the body nuts (14) gradually in a criss-cross pattern.
3. Lift the flange (2) and plug with plug stem (5) off the body (1).
4. Replace gasket as described in section 7.1.1.
5. Unthread the stem connector nut (9) and lock nut (10) from the plug stem.
6. Unscrew the threaded bushing (8).
7. Pull the plug with plug stem (5) out of the flange (2).
8. Pull all the packing parts out of the packing chamber using a suitable tool.
9. Unscrew the seat (4) using a suitable tool.
10. Apply a suitable lubricant to the thread and the sealing cone of the new seat.
11. Screw in the seat (4). Observe tightening torques.
12. Apply a suitable lubricant to all the packing parts and to the new plug stem (5). We recommend replacing the packing as well. See section 7.2.1.
13. Slide the new plug with plug stem (5) into the valve body (1).
14. Place the flange (2) onto the body.
 

**Version with V-port plug:** place the flange (2) onto the valve body, making sure that the largest V-shaped part of the V-port plug faces toward the valve outlet. See section 5.1.
15. Carefully slide the packing parts over the plug stem into the packing chamber using a suitable tool. Make sure to observe the proper sequence (see Fig. 9).
16. Press the plug (5) firmly into the seat (4), while fastening down the flange (2) with the body nuts (14). Tighten the nuts gradually in a criss-cross pattern. Observe tightening torques.
17. Screw in the threaded bushing (8) and tighten it. Observe tightening torques.
18. Loosely screw the lock nut (10) and stem connector nut (9) onto the plug stem.
19. Mount actuator. See associated actuator documentation.
20. Adjust lower or upper signal bench range. See associated actuator documentation.

### 7.3.2 Version with insulating section

1. Remove the actuator from the valve. See associated actuator documentation.
2. Unthread the stem connector nut (9) and lock nut (10) from the plug stem extension (25).
3. Unscrew the threaded bushing (8).
4. Remove nuts (33) and bolts (32).
5. Carefully lift the valve bonnet (2) over the plug stem extension (25).
6. Pull all the packing parts out of the packing chamber using a suitable tool.
7. Undo the body nuts (14) gradually in a criss-cross pattern.
8. Lift the insulating section (21) together with the plug stem extension (25), plug stem and plug (5) off the body (1).
9. Replace gasket as described in section 7.1.2.
10. Make sure that the guide bushing (23) is not damaged. If necessary, replace the guide bushing using a suitable tool.
11. Unscrew the seat (4) using a suitable tool.
12. Apply a suitable lubricant to the thread and the sealing cone of the new seat.
13. Screw in the seat (4). Observe tightening torques.
14. Hold the plug and plug stem (5) stationary using assembly pliers. Unscrew the plug stem extension (25) using a suitable tool and take it out of the insulating section (21).
15. Apply a suitable lubricant to all packing parts and the end of the plug stem of the new plug (5).  
We recommend replacing the packing as well. See section 7.2.2.
16. Make sure that the two washers (30) are still in the plug stem extension (25). Renew the washer, if necessary.
17. Hold the new plug with plug stem (5) stationary. Place on the insulating section (21). Screw the plug stem extension (25) onto the plug stem using a suitable tool. Observe tightening torques.
18. Place the insulating section (21) together with the plug stem extension (25), plug stem and plug (5) onto the body (1).  
**Version with V-port plug:** place the insulating section (21) onto the valve body, making sure that the largest V-shaped part of the V-port plug faces toward the valve outlet. See section 5.1.
19. Press the plug (5) firmly into the seat (4), while fastening down the insulating section (21) with the body nuts (14). Tighten the nuts gradually in a criss-cross pattern. Observe tightening torques.
20. Carefully lift the valve bonnet (2) over the plug stem extension (25) onto the insulating section (21).
21. Carefully slide the packing parts over the plug stem extension into the packing chamber using a suitable tool. Make sure to observe the proper sequence (see Fig. 9).

22. Fasten the valve bonnet with nuts (33) and bolts (32). Observe tightening torques.
23. Screw in the threaded bushing (8) and tighten it. Observe tightening torques.
24. Loosely screw the lock nut (10) and stem connector nut (9) onto the plug stem.
25. Mount actuator. See associated actuator documentation.
26. Adjust lower or upper signal bench range. See associated actuator documentation.

## 7.4 Preparation for return shipment

Defective valves can be returned to SAMSON for repair.

Proceed as follows to return valves to SAMSON:

1. Put the control valve out of operation (see section 9).
2. Decontaminate the valve. Remove any residual process medium.
3. Fill in the Declaration on Contamination, which can be downloaded from our website at ► [www.samson.de](http://www.samson.de) > Services > Check lists for after sales service > Declaration on Contamination.
4. Send the valve together with the filled-in form to your nearest SAMSON subsidiary. SAMSON subsidiaries are listed on our website at ► [www.samson.de](http://www.samson.de) > Contact.

## 7.5 Ordering spare parts and operating supplies

Contact your nearest SAMSON subsidiary or the SAMSON After-sales Service department for information on spare parts, lubricants, and tools.

### Spare parts

See section 10.3 for details on spare parts.

### Lubricant

Details on suitable lubricants can be found in the document ► AB 0100.

### Tools

Details on suitable tools can be found in the document ► AB 0100.

## 8 Malfunctions

Depending on the operating conditions, check the valve at certain intervals to prevent possible failure before it can occur. Operators are responsible for drawing up a test plan.



**Tip:**

*SAMSON's After-sales Service department can support you to draw up an inspection plan for your plant.*

### 8.1 Troubleshooting

Malfunction	Possible reasons	Recommended action
Actuator or plug stem does not move on demand.	Actuator is blocked.	Check attachment. Unblock the actuator.
	Signal pressure too low	Check the signal pressure. Check the signal pressure line for leakage.
Actuator or plug stem does not move through the whole range.	Signal pressure too low	Check the signal pressure. Check the signal pressure line for leakage.
The valve leaks to the atmosphere (fugitive emissions).	The packing is defective.	Replace packing (see section 7.2) or contact SAMSON's After-sales Service department.
	Version with adjustable packing <sup>1)</sup> : packing not tightened correctly.	See section 5.3, "Adjustable packing". Contact SAMSON's After-sales Service department when it continues to leak.
	Version with bellows seal: the metal bellows seal is defective.	Contact SAMSON's After-sales Service department.
	Flange joint loose or gasket worn out.	Check the flange joint. Replace gasket at the flanged joint (see section 7.1 or contact SAMSON's After-sales Service department).



Malfunction	Possible reasons	Recommended action
Increased flow through closed valve (seat leakage)	Dirt or other foreign particles deposited between the seat and plug.	Shut off the section of the pipeline and flush the valve.
	Valve trim, particularly with soft seat, is worn.	Replace seat and plug (see section 7.3 or contact SAMSON's After-sales Service department).

<sup>1)</sup> A label on the flange (2) or yoke (3) indicates whether an adjustable packing is installed.



**Note:**

Contact SAMSON's After-sales Service department for malfunctions not listed in the table.

## 8.2 Emergency action

Upon supply air or control signal failure, the valve moves to its fail-safe position (see section 3.1).

Operators are responsible for emergency action to be taken in the plant.

In the event of a valve malfunction:

1. Close the shut-off valves upstream and downstream of the control valve to stop the process medium from flowing through the valve.
2. Check the valve for damage. If necessary, contact SAMSON's After-sales Service department.

### Putting the valve back into operation after a malfunction

- ➔ Slowly open the shut-off valves. Allow the process medium to flow into the valve slowly.

## 9 Decommissioning and disassembly



### **DANGER!**

*Risk of bursting in pressure equipment.*

*Control valves and pipelines are pressure equipment. Improper opening can lead to bursting of the valve.*

- Before starting any work on the control valve, depressurize all plant sections concerned and the valve.*
- Drain the process medium from all the plant sections concerned as well as the valve.*
- Wear personal protective equipment.*



### **WARNING!**

*Risk of personal injury due to residual process medium in the valve.*

*While working on the valve, residual process medium can escape and, depending on its properties, may lead to personal injury, e.g. (chemical) burns.*

*Wear protective clothing, gloves, and eyewear.*



### **WARNING!**

*Risk of burn injuries due to hot or cold components and pipeline.*

*Valve components and the pipeline may become very hot or cold. Risk of burn injuries.*

- Allow components and pipelines to cool down or heat up.*
- Wear protective clothing and gloves.*

## 9.1 Decommissioning

To decommission the control valve for service and repair work or disassembly, proceed as follows:

1. Close the shut-off valves upstream and downstream of the control valve to stop the process medium from flowing through the valve.
2. Completely drain the pipelines and valve.
3. Disconnect and lock the pneumatic air supply to depressurize the actuator.
4. If necessary, allow the pipeline and valve components to cool down or heat up.

## 9.2 Removing the valve from the pipeline

### **Version with flanges**

1. Put the control valve out of operation (see section 9.1).
2. Unbolt the flange joint.
3. Remove the valve from the pipeline (see section 4.2).

### **Version with welding ends**

1. Put the control valve out of operation (see section 9.1).
2. Cut the pipeline in front of the weld seam.

3. Remove the valve from the pipeline (see section 4.2).

### **9.3 Removing the actuator from the valve**

See associated actuator documentation.

### **9.4 Disposal**

- Observe local, national, and international refuse regulations.
- Do not dispose of components, lubricants, and hazardous substances together with your other household waste.

## 10 Appendix

### 10.1 After-sales service

Contact SAMSON's After-sales Service department for support concerning maintenance or repair work or when malfunctions or defects arise.

#### E-mail

You can reach the After-sales Service Department at [aftersaleservice@samson.de](mailto:aftersaleservice@samson.de).

#### Addresses of SAMSON AG and its subsidiaries

The addresses of SAMSON AG, its subsidiaries, representatives, and service facilities worldwide can be found on the SAMSON website, in all SAMSON product catalogs or on the back of these Mounting and Operating Instructions.

#### Required specifications

Please submit the following details:

- Order number and position number in the order
- Type, model number, nominal size, and valve version
- Pressure and temperature of the process medium
- Flow rate in cu.ft./min or m<sup>3</sup>/h
- Bench range of the actuator (e.g. 0.2 to 1 bar)
- Is a strainer installed?
- Installation drawing

## 10.2 Certificates

Konformitätserklärung/Declaration of Conformity  
Modul/Module A

Für folgende Produkte/For the following pressure equipment:

Geräte/Devices	Bauart/Series	Typ/Type	Ausführung/Version
Durchgangsventil/Globe Valve	240	3241	DIN, Gehäuse GG/Cast iron-Body DN65-125, Gehäuse GGG/Sph. gr. iron-Body DN50-80, Fluide/Fluids <sup>1)</sup>
Durchgangsventil/Globe Valve	240	3241	DIN, Geh. Stahl u.a./Body Steel etc., DN40-100 Fluide/Fluids <sup>2)</sup>
Durchgangsventil/Globe Valve	240	3241	ANSI, Gehäuse GG/Cast iron-Body, CI250 1 1/2"-2", CI125 2 1/2"-4" Fluide/Fluids <sup>1)</sup>
Dreizegeventil/Three-way Valve	240	3244	DIN, Gehäuse GG/Cast iron-Body DN65-125, Gehäuse GGG/Sph. gr. iron-Body DN50-80, Fluide/Fluids <sup>1)</sup>
Dreizegeventil/Three-way Valve	240	3244	DIN, Geh. Stahl u.a./Body Steel etc., DN40-100 Fluide/Fluids <sup>2)</sup>
Schrägsitzventil/Bevel-Valve	---	3353	DIN, Rotgussgehäuse/Bronze-Body, alle Fluide/all Fluids
Schrägsitzventil/Bevel-Valve	---	3353	DIN, Stangengehäuse/Steel-Body Fluide/Fluids <sup>1)</sup>
Durchgangsventile/Globe Valve	V2001	3321	DIN, Gehäuse GG/Cast iron-Body, DN 65-100 Fluide/Fluids <sup>1)</sup>
Durchgangsventile/Globe Valve	V2001	3321	ANSI, Gehäuse GG/Cast iron-Body, 2 1/2"-4" Fluide/Fluids <sup>1)</sup>
Dreizegeventil/Three-way Valve	V2001	3323	DIN, Gehäuse GG/Cast iron-Body, DN 65-100 Fluide/Fluids <sup>1)</sup>
Dreizegeventil/Three-way Valve	V2001	3323	ANSI, Gehäuse GG/Cast iron-Body, 2 1/2"-4" Fluide/Fluids <sup>1)</sup>
Dreizegeventil/Three-way Valve	250	3253	DIN, Gehäuse GG/Cast iron-Body DN200 PN10 Fluide/Fluids <sup>1)</sup>

<sup>1)</sup> Gase nach Artikel 3/Punkt 1.3a zweiter Gedankenstrich/Gases acc. to article 3/chapter 1.3a second line  
Flüssigkeiten nach Artikel 3/Punkt 1.3b/Liquids acc. to article 3/chapter 1.3b

<sup>2)</sup> Gase nach Artikel 3/Punkt 1.3a zweiter Gedankenstrich/Gases acc. to article 3/chapter 1.3a second line  
Flüssigkeiten nach Artikel 3/Punkt 1.3b zweiter Gedankenstrich/Liquids acc. to article 3/chapter 1.3b second line

wird die Konformität mit nachfolgender Anforderung bestätigt/We declare conformity with the demands of the:

Richtlinie des Rates zur Angleichung der Rechtsvorschriften der Mitgliedsstaaten über Druckgeräte/Pressure Equipment Directive	97/23/EG 97/23/EC	vom/of 29.05.1997
Angewandtes Konformitätsbewertungsverfahren/ Applied Conformity Assessment Procedure	Modul A/Module A	durch/by Bureau Veritas 0062
für Fluide nach Artikel 3 Absatz 1/for fluids acc. to art. 3 para. 1		

Das Qualitätssicherungssystem des Herstellers wird von folgender benannten Stelle überwacht/The Manufacturer's Quality Assurance System is monitored by following Notified Body:

Bureau Veritas S. A. nr 0062 6771, boulevard du Château, 92200 Neuilly-sur-Seine, France

Angewandte technische Spezifikation/Technical Standards used: DIN EN12516-2; DIN EN12516-3; ASME B16.34.

Hersteller/Manufacturer:

**SAMSON AG**  
Weismüllerstraße 3  
60314 Frankfurt

Frankfurt, 01.12.2014

ce\_modul\_a\_de\_en\_000.docx

Eugen Nebel  
Zentralabteilungsleiter / Head of Central Department  
Entwicklung Stellgeräte / Control Valve Development

Stephan Michalik  
Zentralabteilungsleiter / Head of Central Department  
Qualitätsmanagement / Quality Management

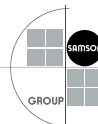

SAMSON AKTIENGESELLSCHAFT  
Weismüllerstraße 3 · 60314 Frankfurt am Main  
Telefon: +49 69 4009-0 · Telefax: +49 69 4009-1507  
Internet: <http://www.samson.de>

Konformitätserklärung/Declaration of Conformity  
**Modul/Module D**  
**N° CE-PED-D-SAM 001-13-DEU**



Für folgende Produkte/For the following pressure equipment:

Geräte/Devices	Bauart/Series	Typ/Type	Ausführung/Version	
Stellgerät für Heißwasser und Dampf mit Sicherheitsfunktion/Safety Accessories for Hot Water and Steam	3374 (2000 N)		mit Typ/with Type No. 2811, 2814, 2823, 3321, 3241, 3267 Zertifikat-Nr./Certificate No.: 01 202 931-B-11-0017	
Sicherheitsabsperreinrichtung für Feuerungsanlagen/ Safety Accessories for Firing Plants	240	3241	3241-4362, Zertifikat-Nr./Certificate No.: 01 202 931-B-11-0018	
	240	3241	3241-4364, Zertifikat-Nr./Certificate No.: 01 202 931-B-11-0019	
Stellgerät für Heißwasser und Dampf mit Sicherheitsfunktion/ Safety Accessories for Hot Water and Steam	240	3241	mit/with 3271, Zertifikat-Nr./Certificate No.: 01 202 931-B-10-0006	
	240, 3267	3241, 3267	mit/with 3271 und/and 3277, 2400m <sup>2</sup> Zertifikat-Nr./Certificate No.: 01 202 931-B-10-0007	
	240, 3267	3241, 3267	mit/with 3271 und/and 3277, 3500m <sup>2</sup> Zertifikat-Nr./Certificate No.: 01 202 931-B-10-0008	
	240	3241	auch druckentlastet/also pressure relieved mit/with 3271 und/and 3277 Zertifikat-Nr./Certificate No.: 01 202 931-B-10-0009	
		3274 (1800 N)		mit/with 3241, 2423, 2823, 3267 Zertifikat-Nr./Certificate No.: 01 202 931-B-10-0027
		3274 (3000 N)		mit/with 3241, 3214, 2814 Zertifikat-Nr./Certificate No.: 01 202 931-B-10-0028
Stellgerät für Wasser und Dampf mit Sicherheitsfunktion/ Safety Accessories for Water and Steam	3222, 3213, 2488, 2489, 2487, 2491, 2494, 2495, 2423, 3214	2770	mit/with 3267, 2814, 2823, 2710, 2730 Zertifikat-Nr./Certificate No.: 01 202 931-B-09-0008	
Sicherheitsabsperreinrichtung für Gasbrenner und Gasgeräte/Safety Accessories for Gas-burners and Gas-Equipment	240	3241	3241-0261 bis/to 3241-0275 Zertifikat-Nr./Certificate No.: 01 202 931-B-02-0017	
Stellgerät zur Leckgasableitung für Gasbrenner und Gasgeräte/Control Valve for draining for Gas-burners and Gas-equipm.	240	3241	3241-4321 Zertifikat-Nr./Certificate No.: 01 202 931-B-02-0018	

wird die Konformität mit nachfolgender Anforderung bestätigt/We declare conformity with the demands of the:

<b>Richtlinie des Rates zur Angleichung der Rechtsvorschriften der Mitgliedsstaaten über Druckgeräte/Pressure Equipment Directive</b>	<b>97/23/EG 97/23/EC</b>	<b>vom/of 29.05.1997</b>
<b>EG-Baumusterprüfbescheinigung/ EC Type Examination Certificate</b>	<b>Modul/Module B</b>	
<b>Angewandtes Konformitätsbewertungsverfahren/ Applied Conformity Assessment Procedure</b>	<b>Modul/Module D</b>	<b>durch/by Bureau Veritas 0062</b>

Das Qualitätssicherungssystem des Herstellers wird von folgender benannten Stelle überwacht/The Manufacturer's Quality Assurance System is monitored by following Notified Body:

**Bureau Veritas S. A. nr 0062 6771, boulevard du Château, 92200 Neuilly-sur-Seine, France**

Hersteller/Manufacturer:

**SAMSON AG**  
**Weismüllerstraße 3**  
**60314 Frankfurt**

Frankfurt, 01.12.2014

*Eugen Nebel*

Eugen Nebel  
 Zentralabteilungsleiter / Head of Central Department  
 Entwicklung Stellgeräte / Control Valve Development

*i.V. Stephan Michalik*

Stephan Michalik  
 Zentralabteilungsleiter / Head of Central Department  
 Qualitätsmanagement / Quality Management

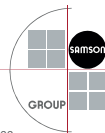

SAMSON AKTIENGESELLSCHAFT  
 Weismüllerstraße 3 · 60314 Frankfurt am Main  
 Telefon: +49 69 4009-0 · Telefax: +49 69 4009-1507  
 Internet: <http://www.samson.de>

Revision 00

ce\_modul\_d\_de\_en\_0010.docx

Konformitätserklärung/Declaration of Conformity  
**Modul/Module H**  
**N° CE-PED-H-SAM 001-13-DEU**



Für folgende Produkte/For the following pressure equipment:

Geräte/Devices	Bauart/Series	Typ/Type	Ausführung/Version
Durchgangsventil/Globe Valve	240	3241	DIN, Gehäuse GG/Cast iron-Body ab/from DN150, Gehäuse GGG/Sph. gr. iron-Body ab/from DN100, Fluide/Fluids <sup>1)</sup> DIN/ANSI, Geh. Stahl u.a./Body Steel etc., alle Fluide/all Fluids
Dreiwegeventil/Three-way Valve	240	3244	DIN, Gehäuse GG ab DN150/Cast iron-Body from DN150; Gehäuse GGG ab DN100/Sph. gr. iron-Body from DN100, Fluide/Fluids <sup>1)</sup> DIN/ANSI, Geh. Stahl u.a./Body Steel etc., alle Fluide/all Fluids
Tieftemperaturventil/Cryogenic Valve	240	3245	DIN/ANSI, alle Fluide/all Fluids
Durchgangsventil/Globe Valve	250	3251	DIN/ANSI, alle Fluide/all Fluids
Dreiwegeventil/Three-way Valve	250	3253	DIN/ANSI, Geh. Stahl u.a./Body Steel etc., alle Fluide/all Fluids
Durchgangsventil/Globe Valve	250	3254	DIN/ANSI, alle Fluide/all Fluids
Eckventil/Angle Valve	250	3256	DIN/ANSI, alle Fluide/all Fluids
Split-Body-Ventil/Split-Body-Valve	250	3258	DIN, alle Fluide/all Fluids
IG-Eckventil/IG-Angle Valve	250	3259	DIN, alle Fluide/all Fluids
Dampfumformventil/ Steam-converting Valve	280	3281	DIN/ANSI, alle Fluide/all Fluids
		3284	DIN/ANSI, alle Fluide/all Fluids
		3286	DIN/ANSI, alle Fluide/all Fluids
		3288	DIN, alle Fluide/all Fluids
Durchgangsventil/Globe Valve	V2001	3321	DIN, Geh. Stahl u.a./Body Steel etc., alle Fluide/all Fluids ANSI, alle Fluide/all Fluids
Dreiwegeventil/Three-way Valve	V2001	3323	DIN, Geh. Stahl u.a./Body Steel etc., alle Fluide/all Fluids ANSI, alle Fluide/all Fluids
Schrägsitzventil/Bevel-Valve	---	3353	DIN, Geh. Stahl/Body Steel, alle Fluide/all Fluids
Drosselschalldämpfer/Silencer	3381	3381-1	DIN/ANSI, alle Fluide/all Fluids; Einzeldrosselscheibe mit Anschweißende/Single attenuation plate with welding end
		3381-3	DIN/ANSI, alle Fluide/all Fluids
		3381-4	DIN/ANSI, alle Fluide/all Fluids; Einzeldrosselscheibe mehrstufig mit Anschweißende/Single attenuation plate multi-stage with welding end
Durchgangsventil/Globe Valve	240	3241	ANSI, Gehäuse GG C1125 ab 5"/Cast iron-Body C1125 from 5" Fluide/Fluids <sup>1)</sup>
Tieftemperaturventil mit Zirkulationssperre/ Cryogenic Valve with Circulation Barrier	240	3246	DIN/ANSI, alle Fluide/all Fluids
Dreiwegeventil/Three-way Valve	250	3253	DIN, Gehäuse GG ab DN200 PN16/Cast iron-Body from DN200 PN16 Fluide/Fluids <sup>1)</sup>
Durchgangsventil/Globe Valve	290	3291	ANSI, alle Fluide/all Fluids
Eckventil/Angle Valve	290	3295	ANSI, alle Fluide/all Fluids
Durchgangsventil/Globe Valve	590	3591	ANSI, alle Fluide/all Fluids
Eckventil/Angle Valve	590	3596	ANSI, alle Fluide/all Fluids

<sup>1)</sup> Gase nach Artikel 3/Punkt 1.3a zweiter Gedankenstrich/Gases acc. to article 3/chapter 1.3a second line  
 Flüssigkeiten nach Artikel 3/Punkt 1.3b/Liquids acc. to article 3/chapter 1.3b

wird die Konformität mit nachfolgender Anforderung bestätigt/We declare conformity with the demands of the:

Richtlinie des Rates zur Angleichung der Rechtsvorschriften der Mitgliedstaaten über Druckgeräte/Pressure Equipment Directive	97/23/EG 97/23/EC	vom/of 29.05.1997
Angewandtes Konformitätsbewertungsverfahren/ Applied Conformity Assessment Procedure	Modul H/Module H	durch/by Bureau Veritas 0062
für Fluide nach Artikel 3 Absatz 1/for fluids acc. to art. 3 para. 1		

Das Qualitätssicherungssystem des Herstellers wird von folgender benannten Stelle überwacht/The Manufacturer's Quality Assurance System is monitored by following Notified Body:

**Bureau Veritas S. A. nr 0062 67/71, boulevard du Château, 92200 Neuilly-sur-Seine, France**

Angewandte technische Spezifikation/Technical Standards used: DIN EN12516-2; DIN EN12516-3; ASME B16.34.

Hersteller/Manufacturer:

**SAMSON AG**  
 Weismüllerstraße 3  
 60314 Frankfurt

Frankfurt, 01.12.2014

  
 Eugen Nebel  
 Zentralabteilungsleiter / Head of Central Department  
 Entwicklung Stelgeräte / Control Valve Development

  
 Stephan Michalik  
 Zentralabteilungsleiter / Head of Central Department  
 Qualitätsmanagement / Quality Management

ce\_modul\_h\_de\_en\_000.docx

SAMSON AKTIENGESELLSCHAFT  
 Weismüllerstraße 3 · 60314 Frankfurt am Main  
 Telefon: +49 69 4009-0 · Telefax: +49 69 4009-1507  
 Internet: http://www.samson.de

Revision 00

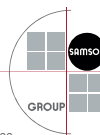

# Konformitätserklärung Declaration of Conformity



Für folgende Produkte: / For the following pressure equipments:

**Ventile für elektrische Stellgeräte**  
Globe and three-way valves equipped with electric actuators

**Type / Type 3213, 3222** (Erz.-Nr./ Model No.. 2710); **3323, 3535** (2803); **3213, 3531** (2811); **3214** (2814); **2423E** (2823); **241** (3241); **244** (3244); **267** (3267);

wird hiermit bestätigt, dass sie mit den Anforderungen konform sind, die festgelegt sind in der  
we declare conformity with the demands of the

Richtlinie des Rates zur Angleichung der Rechtsvorschriften der Mitgliedsstaaten über Druckgeräte.  
**Directive of the Council on the approximation of the laws of the Member States concerning pressure equipment.**

**97/23/EG** vom **29.05.1997**  
97/23/EC of 29 May 1997

Angewandtes Konformitätsbewertungsverfahren für Fluide nach Art. 3 Abs.1 Pkt. 1.3. a erster Gedankenstrich.  
Conformity assessment procedure applied for fluids according to Article 3, Section 1.3 (a), first indent.

Modul siehe Tabelle durch / certified by **Bureau Veritas S. A. (0062)**  
For type of module, see table

Nenndruck Nominal pressure	DN NPS	15 ½	20 ¾	25 1	32 1¼	40 1½	50 2	65	80 3	100 4	125	150 6	200 8	250 10	300 12	400 16
PN 25		ohne (1)				A (2)		H								
PN 40		ohne (1)						H								
ANSI Cl. 150		ohne (1)				A (2)		H								
ANSI Cl. 300		ohne (1)						H								

- (1) Das auf dem Stellgerät aufgebrachte CE-Zeichen hat keine Gültigkeit im Sinne der Druckgeräterichtlinie  
The CE marking affixed to the control device does not refer to the Pressure Equipment Directive.
- (2) Das auf dem Stellgerät aufgebrachte CE-Zeichen gilt ohne Bezeichnung der Benannten Stelle (Kennr. 0062)  
The CE marking affixed to the control device is valid, but does not refer to the notified body (ID No. is invalid).

Geräte, denen laut Tabelle das Konformitätsbewertungsverfahren Modul H zugrunde liegt, beziehen sich auf die „Zulassungsbescheinigung eines Qualitätssicherungssystems“ ausgestellt durch die Benannte Stelle:  
The module H conformity assessment procedure applied to the valves according to the table is based on the "Certificate of Quality System Approval" issued by the notified body: **CE-PED-H-SAM001-13-DEU**

Dem Entwurf zu Grunde gelegt sind Verfahren aus: / The design is based on the methods of:  
DIN EN 12516-2, DIN EN 12516-3 bzw./ respectively ASME B 16.24, ASME B 16.34, ASME B 16.42.

Das Qualitätssicherungssystem des Herstellers wird von folgender benannten Stelle überwacht:  
The manufacturer's quality assurance system is monitored by the following notified body:  
**Bureau Veritas S. A. (0062)**

Hersteller: / Manufacturer:

**SAMSON AG**  
**MESS- UND REGELTECHNIK**  
Weismüllerstr. 3  
60314 Frankfurt am Main  
Germany

Datum / Date: 2014-08-01

  
Rudolf Lässer  
Zentralabteilungsleiter Entwicklung ROH / Stellventile Gebäudeautomation  
Head of Development Department SOR / Valves for Building Automation

  
Stephan Michalik  
Zentralabteilungsleiter Qualitätsmanagement  
Head of Quality Management Department

Bearb. / Created	2001-11-21	Ste	15	60388	2014-08-04	Lae	WT	<b>1 0 1 0 - 4 0 7 5</b>	<b>15</b>	<b>10</b>
Gepr. / Checked	2001-11-24	Lae	14	59546	2013-07-19	Lae	WT			
Norm / Standard	2002-02-22	WT	Zust. / State	Nr. / No.				<b>Konformitätserklärung</b> Declaration of Conformity	Änd.-Zust. Mod.	Blatt Nr. Page No.
					Änderung Modification					



# Konformitätserklärung

## Declaration of Conformity



Für folgende Produkte: / For the following pressure equipments:

### Ventile für elektrische Stellgeräte

#### Globe and three-way valves equipped with electric actuators

Typ / Type **3213, 3222** (Erz.-Nr./ Model No. 2710); **3226, 3260\*** (2713\*); **3323, 3535** (2803); **3213, 3531** (2811); **3214** (2814); **2423E** (2823); **241** (3241); **244** (3244); **267** (3267);

wird hiermit bestätigt, dass sie mit den Anforderungen konform sind, die festgelegt sind in der  
we declare conformity with the demands of the

**Richtlinie des Rates zur Angleichung der Rechtsvorschriften der Mitgliedsstaaten über Druckgeräte.**  
*Directive of the Council on the approximation of the laws of the Member States concerning pressure equipment.*

97/23/EG vom 29.05.1997

97/23/EC of 29 May 1997

**Angewandtes Konformitätsbewertungsverfahren für Fluide nach Art. 3 Abs.1 Pkt. 1.3.b und Pkt. 1.3.a zweiter Gedankenstrich.**  
*Conformity assessment procedure applied for fluids according to Article 3, Section 1.3 (b) and Section 1.3 (a), second indent.*

**Modul siehe Tabelle**  
*For type of module, see table*

durch / certified by  
**Bureau Veritas S. A. (0062)**

Nenndruck Nominal pressure	DN NPS	15 ½	20 ¾	25 1	32 1¼	40 1½	50 2	65	80 3	100 4	125	150 6	200 8	250 10	300 12	400 16	
PN 16		ohne/without (1)				A (2)				H							
PN 25		ohne/without (1)				A (2)				H							
PN 40		ohne/without (1)				A (2)				H							
ANSI Cl. 150		ohne/without (1)				A (2)				H							
ANSI Cl. 300		ohne/without (1)				A (2)				H							

(1) Das auf dem Stellgerät aufgebrachte CE-Zeichen hat keine Gültigkeit im Sinne der Druckgeräterichtlinie  
*The CE marking affixed to the control device does not refer to the Pressure Equipment Directive.*

(2) Das auf dem Stellgerät aufgebrachte CE-Zeichen gilt ohne Bezeichnung der Benannten Stelle (Kennr. 00062)  
*The CE marking affixed to the control device is valid, but does not refer to the notified body (ID No. is invalid).*

\* Für Ventile vom Typ 3260 sind ab DN 150 Fluide nach Art. 3 Abs.1 Pkt. 1.3.b erster Gedankenstrich nicht zugelassen.  
*Fluids according to Art. 3, Sect. 1.3 (b), first indent are not permissible for Type 3260 Valves with DN equal or bigger than 150.*

**Geräte, denen laut Tabelle das Konformitätsbewertungsverfahren Modul H zugrunde liegt, beziehen sich auf die „Zulassungsbescheinigung eines Qualitätssicherungssystems“ ausgestellt durch die Benannte Stelle:**  
*The module H conformity assessment procedure applied to the valves according to the table is based on the "Certificate of Quality System Approval" issued by the notified body: CE-PED-H-SAM001-13-DEU*

**Dem Entwurf zu Grunde gelegt sind Verfahren aus:** / *The design is based on the methods of:*

DIN EN 12516-2, DIN EN 12516-3 bzw./ respectively ASME B 16.1, ASME B 16.24, ASME B 16.34, ASME B 16.42.

**Das Qualitätssicherungssystem des Herstellers wird von folgender benannten Stelle überwacht:**

*The manufacturer's quality assurance system is monitored by the following notified body:*

**Bureau Veritas S. A. (0062)**

Hersteller / Manufacturer:

**SAMSON AG**  
**MESS- UND REGELTECHNIK**  
Weismüllerstr. 3  
60314 Frankfurt am Main  
Germany

Datum / Date: 2014-08-01

*i.v.R. Gausel*  
Rudolf Lässler  
Zentralabteilungsleiter Entwicklung ROH / Stellventile Gebäudeautomation  
Head of Development Department SOR / Valves for Building Automation

*i.V. Michalik*  
Stephan Michalik  
Zentralabteilungsleiter Qualitätsmanagement  
Head of Quality Management Department

Bearb. / Created	2001-11-21	Ste	15	60388	2014-08-04	Lae	Wt	<b>1 0 1 0 - 4 0 7 5</b>	<b>15</b>	<b>6</b>	
Gepr. / Checked	2001-11-24	Lae	14	59546	2013-07-19	Lae	Wt				
Norm / Standard	2002-02-22	Wt	Zust. / State	Nr. / No.							
	Änderung Modification							<b>Konformitätserklärung</b> <i>Declaration of Conformity</i>	Änd.-Zust. Mod.	Blatt Nr. Page No.	



## 10.3 Spare parts

### Legend

1	Body	42	Screw plug with seal
2	Flange/valve bonnet	44	Ring/ring nut <sup>1)</sup>
3	Yoke	45	Packing ring <sup>1)</sup>
4	Seat	46	Gasket <sup>1)</sup>
5	Plug (with plug stem)	47	Support <sup>1)</sup>
7	Guide bushing (flange)	48	Hexagon screw <sup>1)</sup>
8	Threaded bushing (packing nut)	49	Hexagon screw <sup>1)</sup>
9	Stem connector nut	50	Lock <sup>1)</sup>
10	Lock nut	51	Guide <sup>1)</sup> (several guides only for version with graphite seal)
11	Spring	52	Ring <sup>1)</sup> (only for version with graphite seal)
12	Washer	53	Snap ring <sup>1)</sup>
13	Stud bolt	61	Flow divider II <sup>2)</sup>
14	Body nut	62	Flow divider I or III <sup>2)</sup>
15	Packing (adjustable)	63	Ring <sup>2)</sup>
16	Packing	64	Gasket <sup>2)</sup>
17	Body gasket	65	Gasket <sup>2)</sup>
19	Bushing	80	Nameplate
21	Insulating section	81	Grooved pin
22	Bellows seal	82	Screw
23	Guide bushing (insulating section)	83/84	Travel indicator scale
24	Guide bushing (bellows seal)	85	Screw
25	Plug stem extension	90	Cap
26	Label (bellows seal or insulating section)	91	Protective cap
27/28	Fastening parts	92	Nut
31/34		101	Bellows bonnet
29	Plug for version with bellows seal	102	Screw with snap ring <sup>1)</sup> (only for version with bellows seal)
30	Washers		
32	Bolt		
33	Nut		
37	Plug stem with bellows		
39	Gasket		
41	Nut		

<sup>1)</sup> Version with balanced valve plug

<sup>2)</sup> Version with flow divider

DN 15...150  
NPS 1/2...6

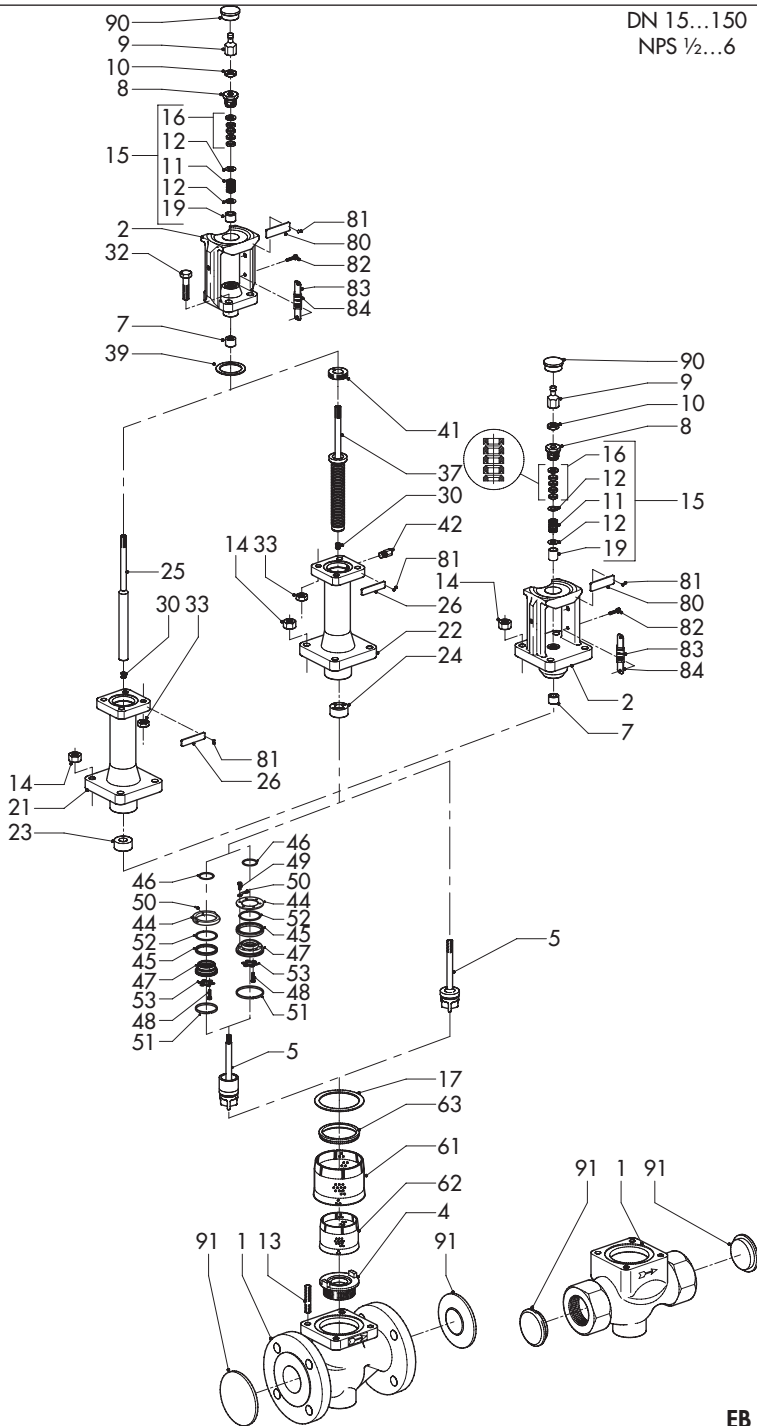

DN 200...300  
NPS 8...12

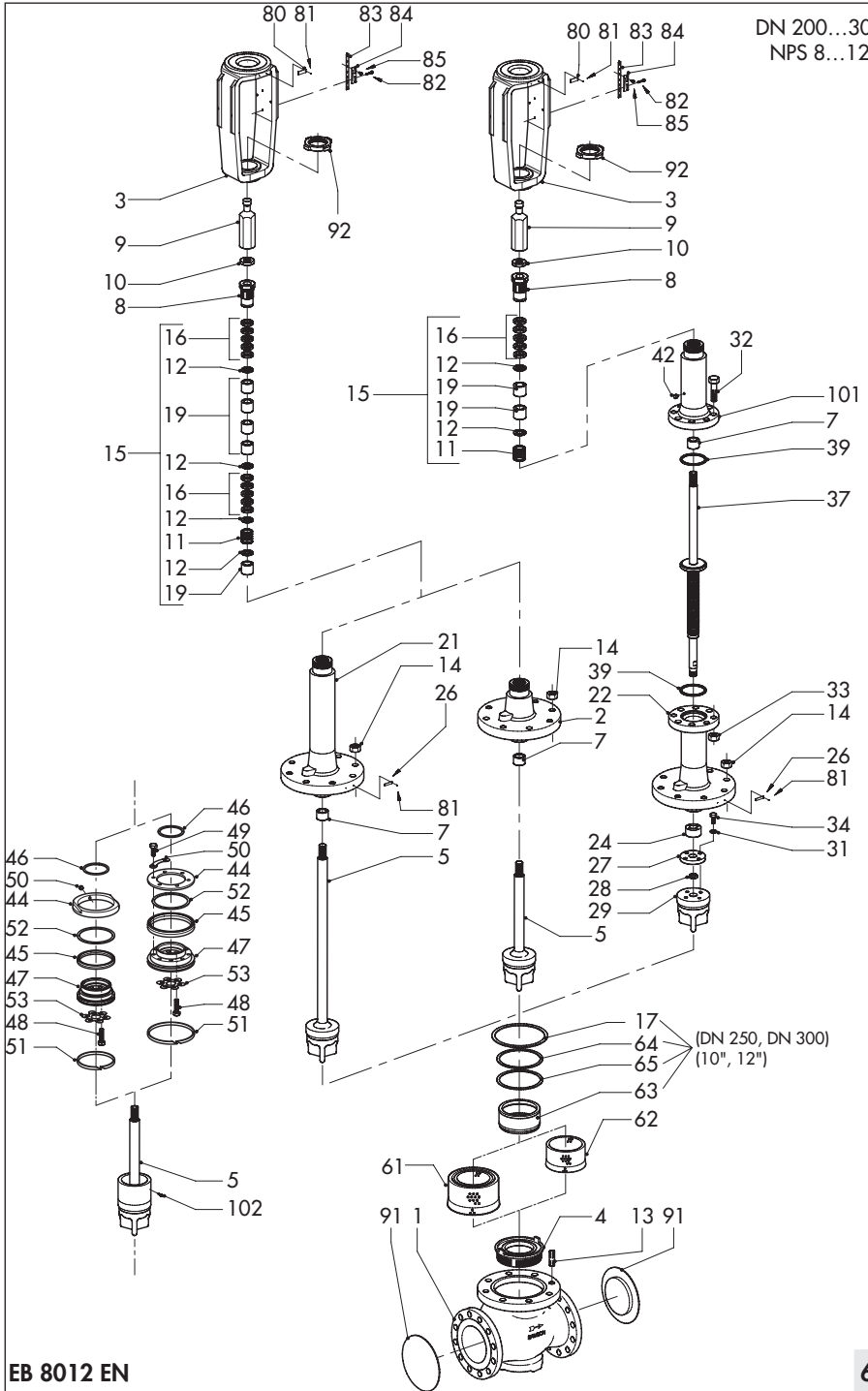







SAMSON AG · MESS- UND REGELTECHNIK  
Weismüllerstraße 3 · 60314 Frankfurt am Main, Germany  
Phone: +49 69 4009-0 · Fax: +49 69 4009-1507  
samson@samson.de · www.samson.de

**EB 8012 EN**

2016-03-16 · English